

**109-1230b**

Seite/Page 1 / 3

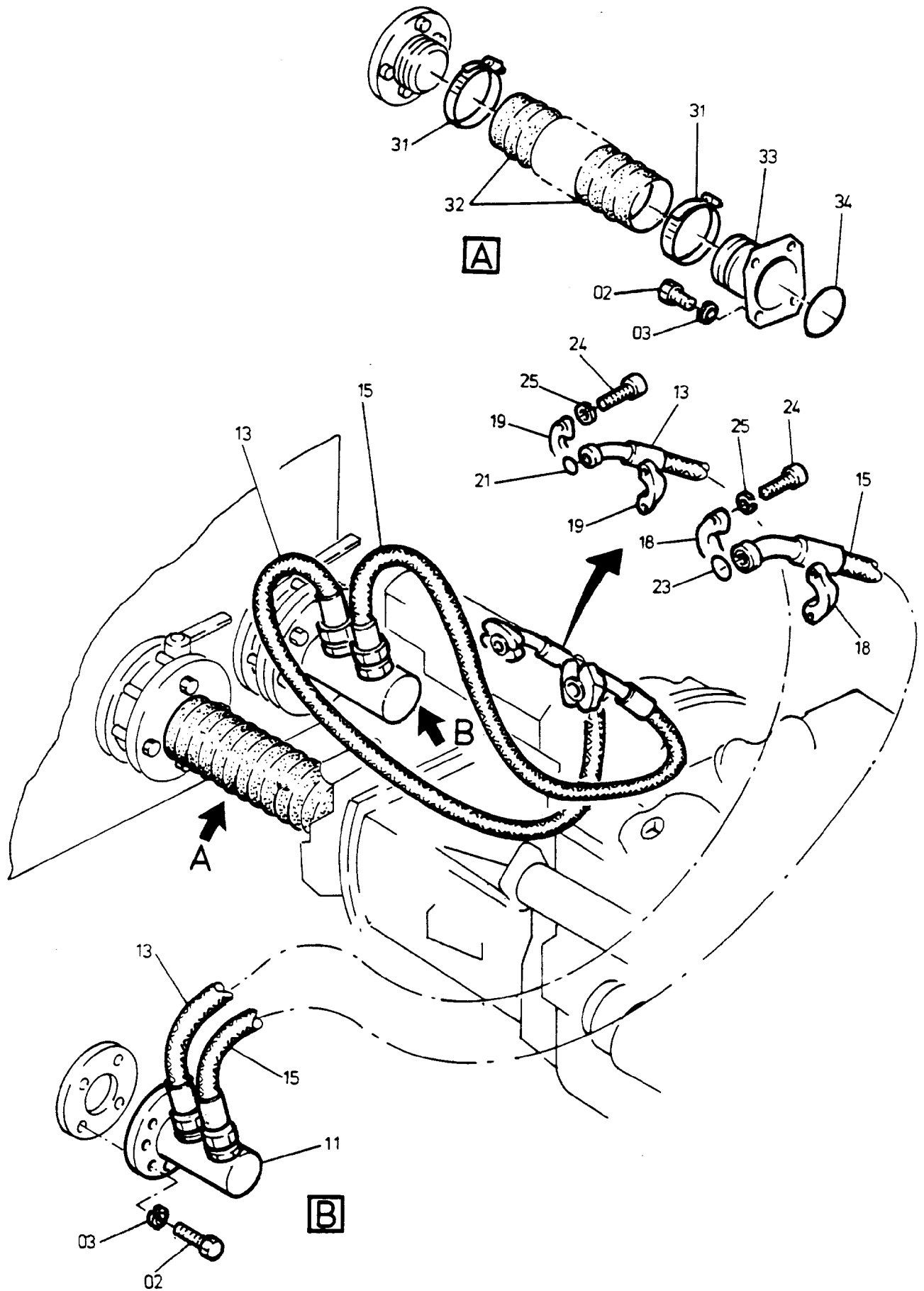

**109-1230b**

Seite/Page 2 / 3

Bild-Nr Fig Fig Fig Fig Bild nr	ET-Nr Part-No No. de Piece No. de Pieza No. del Pezzo Detalj nr	Stückzahl Qty Qte Ctd Qta Antal		Gegenstand Description Designation Descripcion Designazione Benaemning
01	323 498 40	1	Kompensator	Compensator
02	307 825 99	16	Schraube	Screw
03	343 116 99	24	Federring	Lock washer
04	307 368 99	8	Schraube	Screw
05	332 336 99	8	Mutter	Nut
06	328 696 40	1	Rohr	Pipe
07	231 807 40	2	Dichtung	Gasket
11	407 837 40	1	Verteiler	Manifold
13	446 005 40	1	Schlauchleitung	Hose assy.
15	446 006 40	1	Schlauchleitung	Hose assy.
18	145 825 40	2	Flanshhälfte	Half flange
19	006 635 98	2	Flanshhälfte	Half flange
21	006 729 98	1	O-Ring	O-ring
23	006 734 98	1	O-Ring	O-Ring
24	319 157 99	8	Schraube	Screw
25	343 856 99	8	Federring	Lock washer
31	501 330 98	2	Schelle	Clamp
32	173 465 40	1	Spiralschlauch	Hose
33	328 675 40	1	Flansch	Flange
34	367 136 99	1	O-Ring	O-ring

**Saugleitungen am Hydraulikölbehälter**  
**Suction Lines on Hydr. Oil Tank**

**109-1230b**

Seite/Page 3 / 3