

01

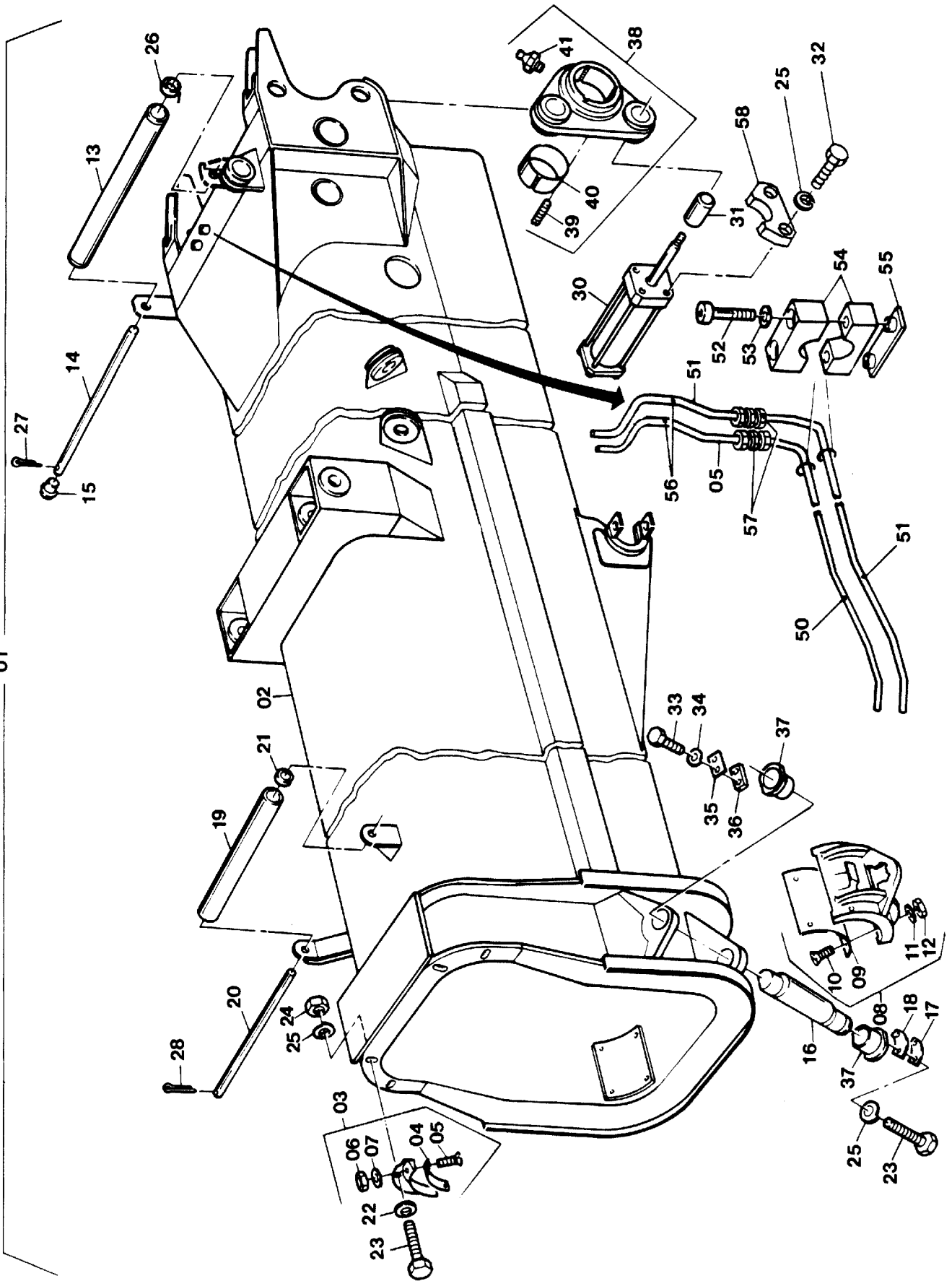

109-6020-2

Seite/Page 1 / 3

Bild-Nr Fig Fig Fig Fig Bild nr	ET-Nr Part-No No. de Piece No. de Pieza No. del Pezzo Detalj nr	Stückzahl Qty Qte Ctd Qta Antal		Gegenstand Description Designation Descripcion Designazione Benaemning
01	344 875 40	1	Grundkasten, kpl.	Basic case, assy.
02	344 849 40	1	Grundkasten (SK)	Basic case (steel construction)
03	322 017 40	2	Obere Führung, kpl. einschl. Bild-Nr. 04-07	Guide above, assy. incl. fig-nos. 04-07
04	322 022 40	2	Gleitstück	Slider
05	320 433 99	6	Schraube	Screw
06	332 111 99	6	Mutter	Nut
07	003 121 98	6	Dubo-Sicherung	Screw lock
08	344 885 40	2	Gleitschuh, unten, kpl. einschl. Bild-Nr. 09-12	Guide shoe, below, assy. incl. fig-nos: 09-12
09	344 886 40	2	Gleitstück	Slider
10	321 229 99	8	Schraube	Screw
11	003 121 98	8	Dubo-Sicherung	Screw lock
12	332 111 99	8	Mutter	Nut
13	262 365 40	1	Walzenkörper	Roller body
14	262 366 40	1	Achse	Axle
15	179 066 40	2	Buchse	Bush
16	344 887 40	2	Achse	Axle
17	344 890 40	2	Halter	Bracket
18	344 889 40	2	Halter	Bracket
19	285 297 40	3	Rohr	Pipe
20	285 298 40	3	Stange	Rod
21	322 104 40	6	Buchse	Bush
22	322 102 40	8	Scheibe	Washer
23	308 631 99	4	Schraube	Screw
24	003 818 98	4	Mutter	Nut
25	343 116 99	24	Federring ø 16	Lock washer
25	343 117 99	8	Federring ø 20	Lock washer
26	368 248 99	2	Kugellager	Ball bearing
27	342 103 99	2	Splint	Split pin
28	342 063 99	6	Splint	Split pin
30	-	4	Bolzenzylinder (Kundenwunsch) siehe EL-Blatt 109-6021	Pin cylinder (optional equipment) see page 109-6021
31	322 101 40	4	Bolzen, 170 lg.	Pin
31	434 727 40	4	Bolzen, 352 lg.	Pin
32	500 062 98	16	Schraube, bei Ausführung mit Bild-Nr. 30	Screw for equipment with fig-no: 30
32	325 615 99	8	Schraube, bei Ausführung ohne Bild-Nr. 30	Screw for equipment w/o. fig-no: 30

**Grundkasten
Basic Case**

109-6020-2

Seite/Page 2 / 3

Bild-Nr Fig Fig Fig Fig Bild nr	ET-Nr Part-No No. de Piece No. de Pieza No. del Pezzo Detalj nr	Stückzahl Qty Qte Ctd Qta Antal		Gegenstand Description Designation Descripcion Designazione Benaemning
33	307 750 99	4	Schraube	Screw
34	346 510 99	4	Federring	Lock washer
35	311 367 40	2	Blech	Strip
36	311 390 40	2	Knagge	Plate
37	344 888 40	4	Buchse	Bush
38	322 005 40	2	Fußlager einschl. Bild-Nr. 39-41	Boom butt bearing incl. fig-nos: 39-41
39	324 455 99	6	Gewindestift	Threaded pin
40	322 006 40	2	Buchse	Bush
41	350 562 99	2	Schmiernippel	Grease nipple
50	321 998 40	1	Rohrleitung ø 30	Pipe
51	321 997 40	1	Rohrleitung ø 30	Pipe
52	319 417 99	16	Schraube	Screw
53	340 405 99	16	Scheibe	Washer
54	501 559 98	16	Schelle	Clamp
55	501 584 98	1	Platte	Plate
56	335 628 40	2	Rohrleitung	Pipe, assy.
57	372 416 99	2	Verschraubung	Union
58	434 728 40		Achshalter, bei Ausführung ohne Bild-Nr. 30	Axle stirrup for equipment w/o. fig-no: 30
-	255 616 40	-	Antirutschbelag (Länge angeben)	Safety rubber (state length required)