

117-6025

Seite/Page 1 / 5

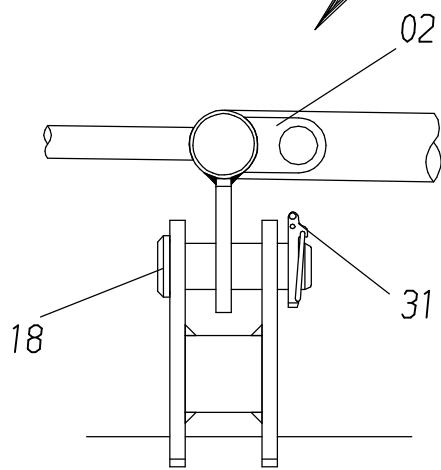

Schnitt L-L

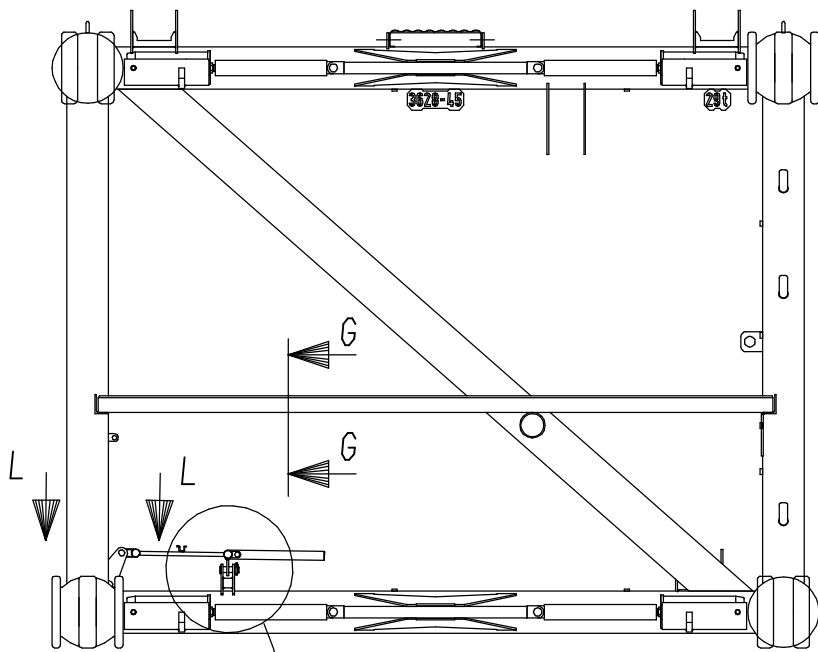
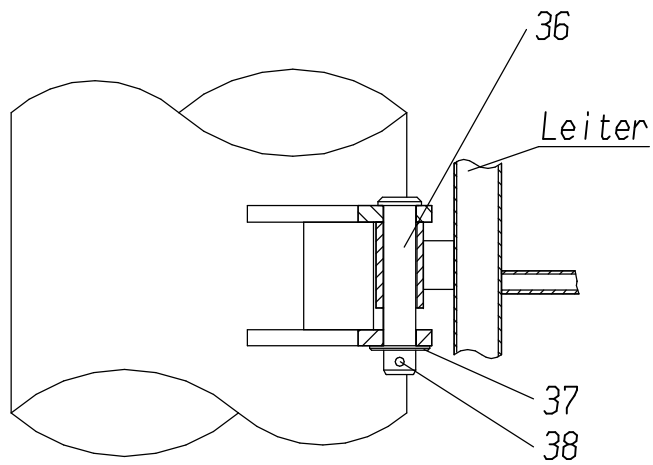
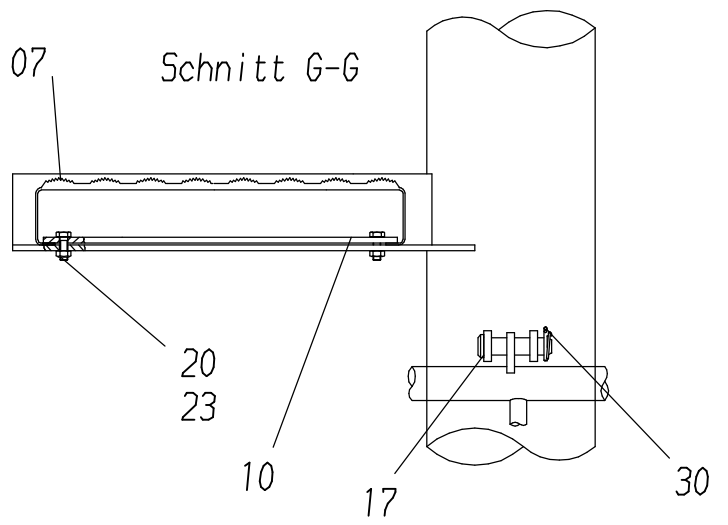

117-6025

Seite/Page 2 / 5

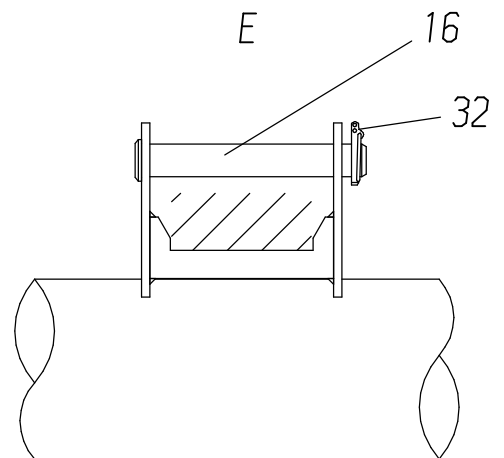
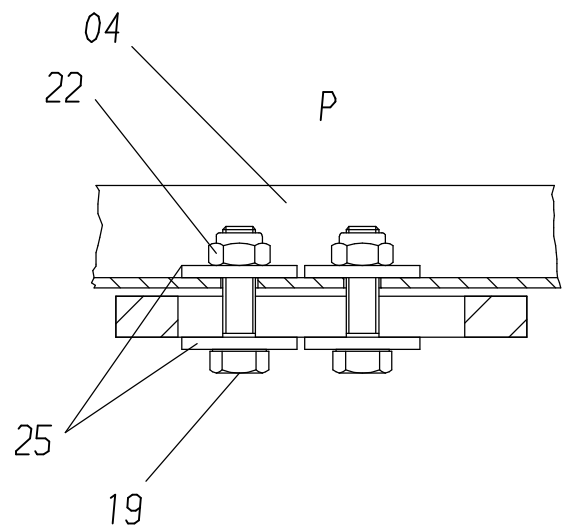
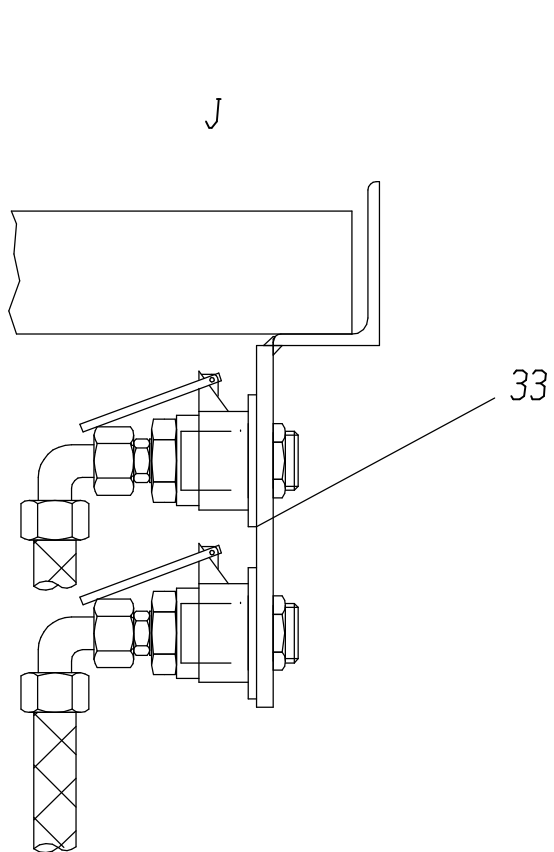
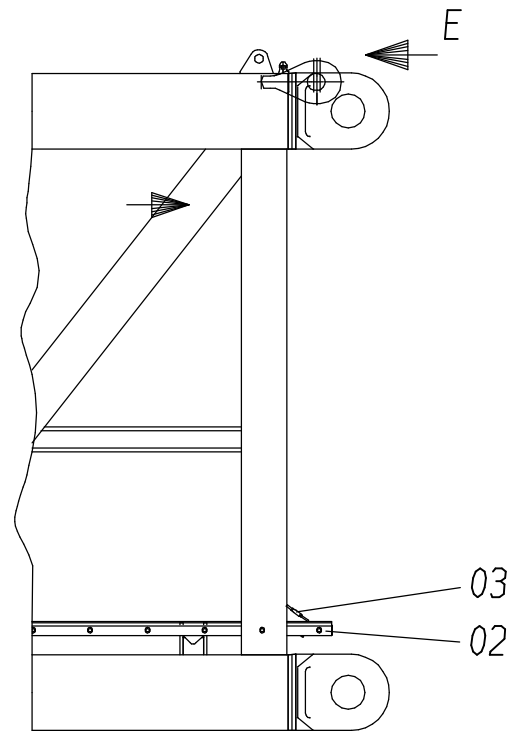
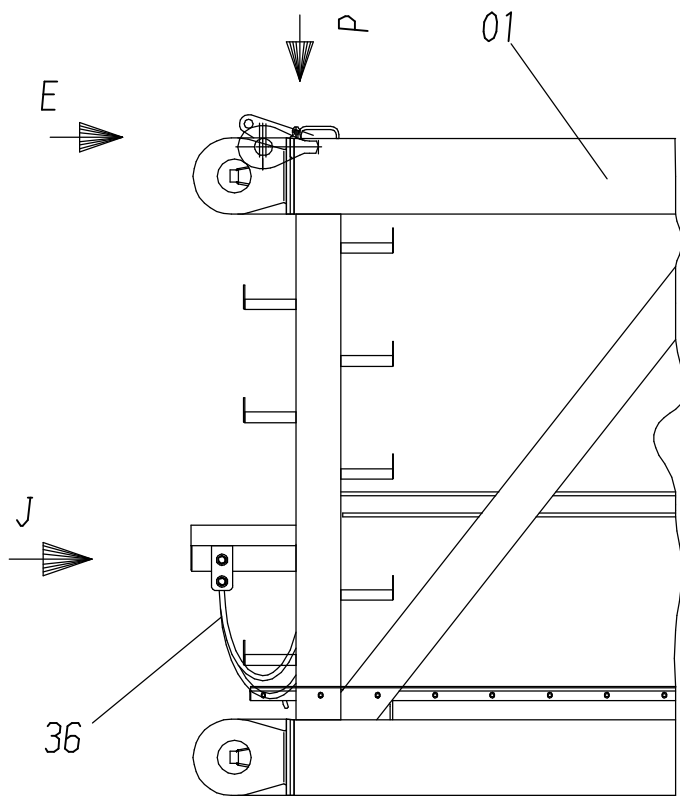

117-6025

Seite/Page 3 / 5

Bild-Nr Fig Fig Fig Fig Bild nr	ET-Nr Part-No No. de Piece No. de Pieza No. del Pezzo Detalj nr	Stückzahl Qty Qte Ctd Qta Antal		Gegenstand Description Designation Descripcion Designazione Benaemning
-	657 284 40	1	Zwischenstück 12 m, kpl.	Extension 12 m assy.
01	656 709 40	1	Zwischenstück 12 m, SK	Extension 12 m, weldment
02	871 478 40	1	Leiter	Ladder
03	-	1	Fallschutz s. EL-Blatt 117-6092	Falling protection see page 117-6092
04	592 283 40	1	Sicherheitsrost	Grid
05	871 448 40	1	Sicherheitsrost	Grid
06	871 443 40	1	Sicherheitsrost	Grid
07	420 962 40	1	Sicherheitsrost	Grid
08	654 241 40	8	Stützrolle	Roller
09	676 291 40	4	Verriegelungszyylinder	Locking cylinder
-	420 065 12	4	Dichtsatz zu Bild-Nr. 09	Seal kit to fig-no: 09
10	676 974 40	2	Halter	Retainer
11	676 971 40	4	Steckbolzen	Pin
12	513 298 98	4	Bolzen	Pin
13	676 970 40	4	Sicherungsbolzen	Safety pin
14	871 439 40	8	Bolzen	Pin
15	490 475 40	4	Sicherungsbolzen, kpl.	Safety pin assy.
16	871 441 40	4	Bolzen	Pin
17	871 454 40	2	Bolzen	Pin
18	677 590 40	1	Bolzen	Pin
19	307 429 99	24	Schraube	Screw
20	500 853 98	4	Schraube	Screw
21	512 701 98	4	Mutter	Nut
22	334 673 99	24	Mutter	Nut
23	332 197 99	4	Mutter	Nut
24	340 625 99	4	Scheibe	Washer
25	350 763 99	48	Scheibe	Washer
26	513 436 98	24	Scheibe	Washer
27	342 123 99	4	Splint	Cotter pin
28	342 142 99	8	Splint	Cotter pin
29	007 266 98	8	Sicherungsfeder	Safety spring
30	511 617 98	2	Klappstecker	Fore lock
31	511 618 98	2	Klappstecker	Fore lock
32	551 052 40	4	Klappstecker	Fore lock
33	871 518 40	1	Halter	Retainer
34	513 775 98	8	Kgelschmiernippel	Grease nipple
35	-	1	Hydr. zum Zwischenstück s. EL-Blatt 117-6090	Hydr. to extension see page 117-6090
36	871 545 40	1	Bolzen	Pin
37	340 472 99	1	Scheibe	Washer

**Zwischenstück 12 m (Typ 3628-40)
Extension 12 m (Type 3628-40)**

117-6025

Seite/Page 4 / 5

Bild-Nr Fig Fig Fig Fig Bild nr	ET-Nr Part-No No. de Piece No. de Pieza No. del Pezzo Detalj nr	Stückzahl Qty Qte Ctd Qta Antal		Gegenstand Description Designation Descripcion Descrizione Benaemning
38	342 121 99	1	Splint	Cotter pin
Zwischenstück 12 m (Typ 3628-40) Extension 12 m (Type 3628-40)				117-6025