

Elektrik Rollenkopf 1600 t
 Elektric Roller head 1600 t

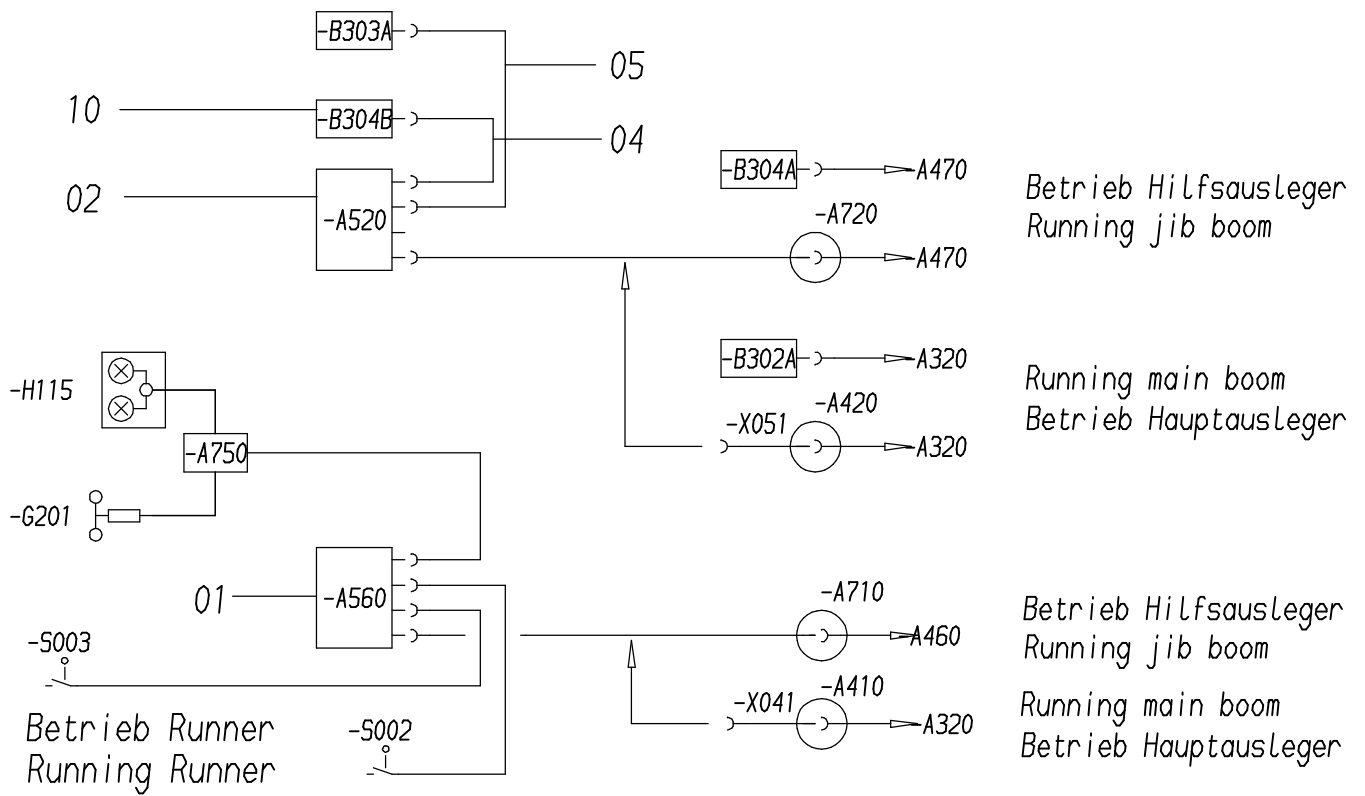

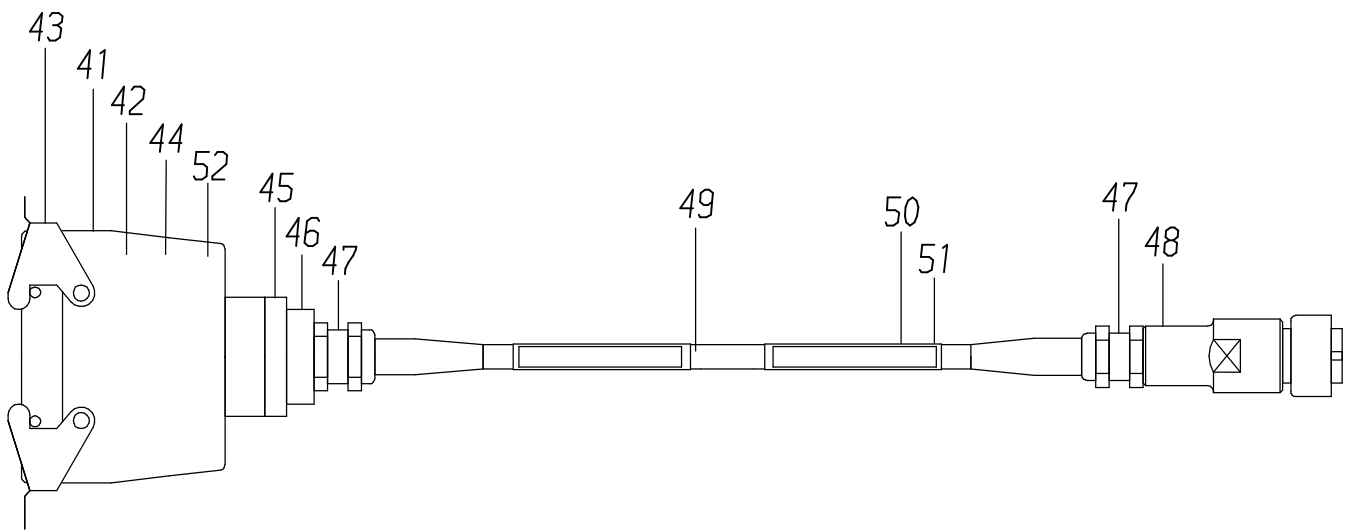

117-6222

Seite/Page 2 / 3

Bild-Nr Fig Fig Fig Fig Bild nr	ET-Nr Part-No No. de Piece No. de Pieza No. del Pezzo Detalj nr	Stückzahl Qty Qte Ctd Qta Antal		Gegenstand Description Designation Descripcion Designazione Benaemning
01	-	1	Verteilerkasten A 560 "Steuerung" s. EL-Blatt 117-6225, etc.	Distributor box A 560 "control" see page 117-6225, etc.
02	-	1	Verteilerkasten A 570 "LMB" s. EL-Blatt 117-6228, etc.	Distributor box A 570 "LLD" see page 117-6228, etc.
04	662 892 40	1	Kabelwinkelgeber best. aus Bild 41-52	Cable "angle transmitter roller head" consist of fig no. 41-52
05	662 893 40	1	Kabelkraftgeber best. aus Bild 41-52	Cable "force transmitter" consist of fig no. 41-52
10	635 134 40	1	Winkelgeber	Angle transmitter
41	002 136 12	1	Tüllengehäuse	Socket
42	002 141 12	1	Steckdoseneinsatz	Socket insert
43	002 139 12	1	Schutzdeckel	Safety cap
44	002 142 12	2	Codierbolzen	Code pin
45	414 528 40	1	Reduzierstück	Reducer
46	414 525 40	1	Reduzierstück	Reducer
47	604 172 40	2	Kabelverschraubung	Cable union
48	635 146 40	1	Stecksatz 3-pol.	Elbow plug 3-pol.
49	*	-	Kabel 4-pol.	Cable 4-pol.
50	634 455 40	1	Schriftbandrolle	Inscription tape roll
51	621 774 40	1	Schrumpfschlauch	Shrink down tubing
52	592 168 40	1	Vergussmasse * Meterware, bei Bestellung Länge angeben	Sealing compound * Bulk ware, state length required
*	635 879 40	-	Kabel 4-pol.	Cable 4-pol.