

**123-1861b**

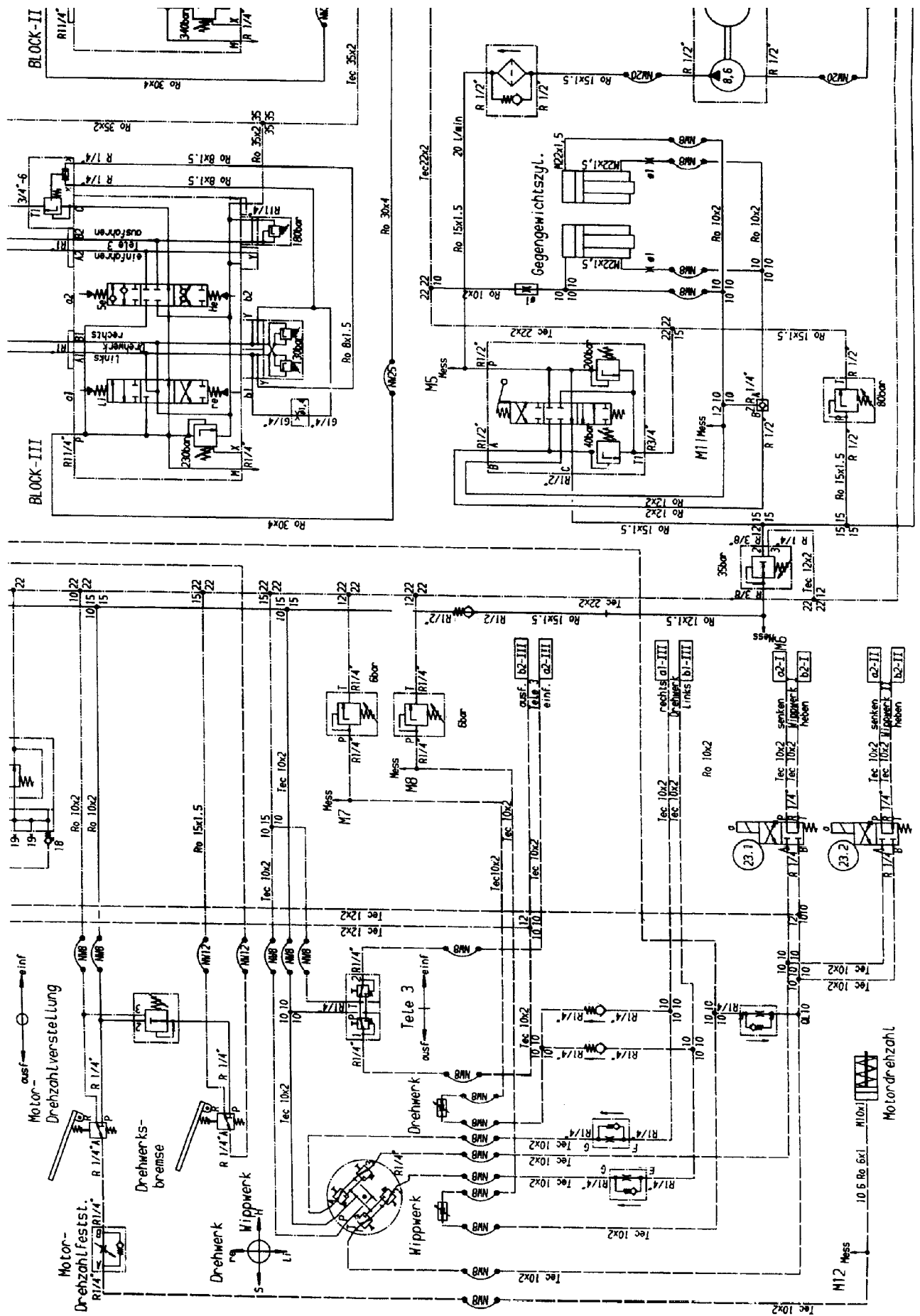

123-1861b

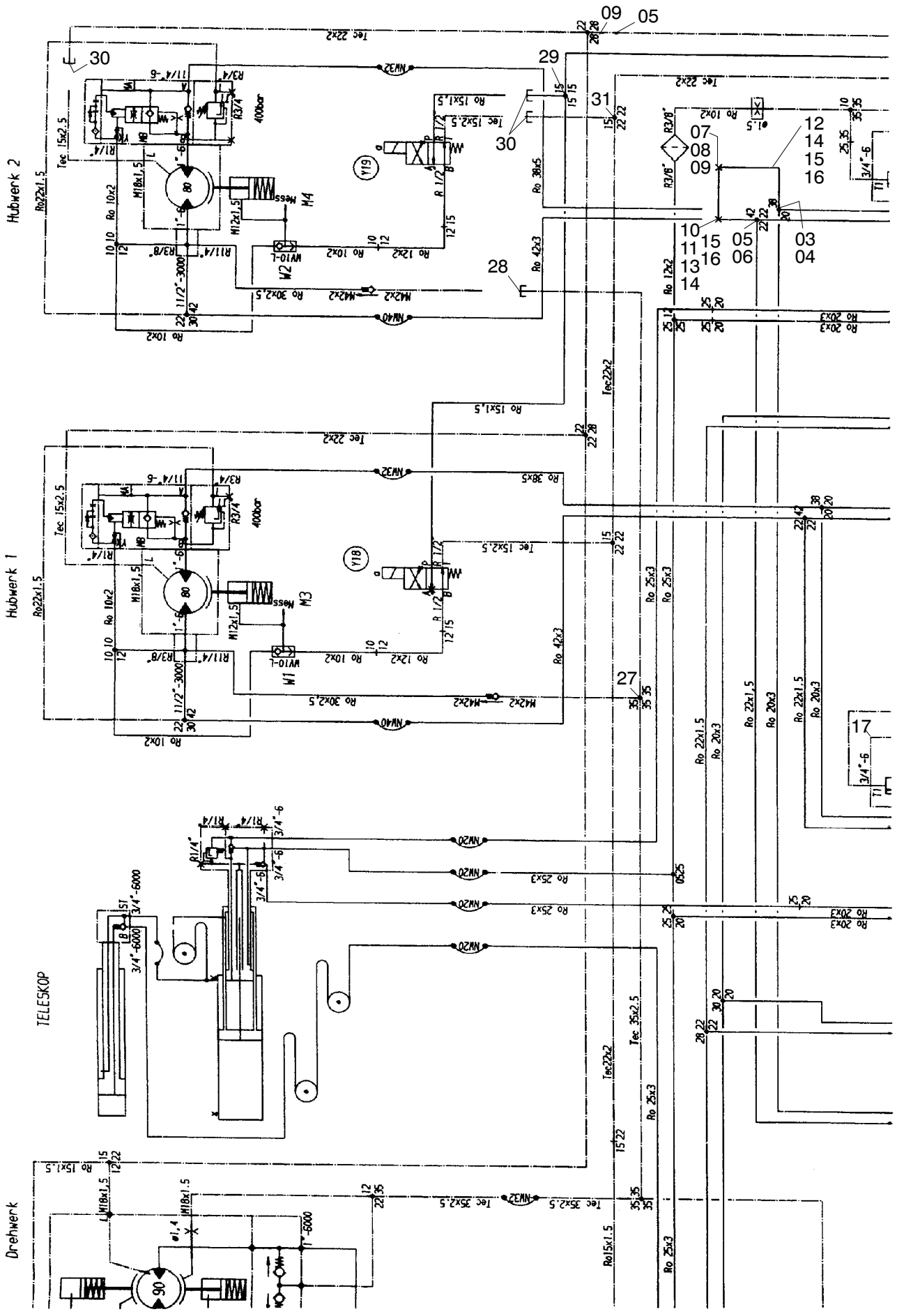

123-1861b



Bild-Nr Fig Fig Fig Fig Bild nr	ET-Nr Part-No No. de Piece No. de Pieza No. del Pezzo Detalj nr	Stückzahl Qty Qte Ctd Qta Antal		Gegenstand Description Designation Descripción Designazione Benaeming
				552 204 40
01	551 529 40	2	Stutzen	Socket
02	551 306 40	2	Stutzen	Socket
03	634 495 40	1	Stutzen	Socket
04	634 533 40	2	Stutzen	Socket
05	372 619 99	1	Verschraubung	Union
06	621 013 40	2	Stutzen	Socket
07	634 634 40	1	Stutzen	Socket
08	372 993 99	1	Verschraubung	Union
09	372 182 99	1	Verschraubung	Union
10	511 438 98	1	Stutzen	Socket
11	372 929 99	1	Verschraubung	Union
12	534 019 99	2	Schellenhälfte	Half clamp
13	500 865 98	2	Schellenhälfte	Half clamp
14	534 004 99	2	Deckplatte	Cover plate
15	308 541 99	4	Schraube	Bolt
16	504 030 98	4	Mutter	Nut
17	551 687 40	1	Druckwaage	Pressure compensator
18	490 575 40	1	Rückschlagventil	Non-return valve
19	440 822 40	1	Siebelement	Strainer
20	551 349 40	2	Stutzen	Socket
31	551 758 40	1	Abschaltventil (Y5)	Cut off valve
32	226 956 40	1	Magnetventil (Y22)	Solenoid valve
33	176 223 40	2	Grundplatte	Base plate
34	226 959 40	1	Magnetventil (Y1b)	Solenoid valve
35	372 617 99	1	Verschraubung	Union
36	414 161 40	1	Druckschalter, 8bar (S19a)	Pressure switch
37	226 480 40	1	Drosselventil	Flow control valve
38	226 479 40	1	Druckspeicher, 10bar	Accumulator
39	621 053 40	1	Stutzen	Socket
40	509 590 98	5	Stutzen	Socket
41	634 483 40	1	Stutzen	Socket
42	004 398 98	1	Stutzen	Socket
43	509 461 98	1	Stutzen	Socket
44	551 349 40	11	Stutzen	Socket
45	371 700 99	1	Verschraubung	Union
46	621 400 40	1	Stutzen	Socket
47	621 401 40	1	Stutzen	Socket
48	502 346 98	1	Rückschlagventil, 0,2bar	Non-return valve
49	180 477 40	6	Verschlußschraube	Screw plug

Hydr. Hubwerk II  
Hydr. Hoist II

123-1861b

Seite/Page 5 / 6

Bild-Nr Fig Fig Fig Fig Bild nr	ET-Nr Part-No No. de Piece No. de Pieza No. del Pezzo Detalj nr	Stückzahl Qty Qte Ctd Qta Antal		Gegenstand Description Designation Descripcion Designazione Benaeming
50	180 113 40	1	Verschlußschraube	Screw plug
51	308 559 99	2	Schraube	Bolt
52	319 174 99	8	Schraube	Screw
53	343 852 99	8	Federring	Lock washer
54	307 280 99	2	Schraube	Bolt
55	332 110 99	2	Mutter	Nut
56	346 499 99	2	Federring	Lock washer
57	509 548 98	1	Stutzen	Socket
58	371 859 99	1	Verschlußschraube	Screw plug
59	509 550 98	1	Stutzen	Socket
60	371 855 99	3	Verschlußschraube	Screw plug
61	373 759 99	1	Verschraubung	Union
62	510 222 98	1	Stutzen	Socket
63	253 577 40	5	Schild	Label
64	243 420 40	2	Schlüsselring	Ring
65	533 984 99	12	Schellenhälfte	Half clamp
66	504 030 98	12	Mutter	Nut
67	501 539 98	72	Hülse	Sleeve
68	159 966 40	70	Klemmring	Clamping ring
69	007 580 98	8	Hülse	Sleeve
70	180 056 40	8	Klemmring	Clamping ring
71	007 578 98	3	Hülse	Sleeve
72	180 054 40	3	Klemmring	Clamping ring
73	515 901 40	1	Drossel-Rückschlagventil	Throttle valve
74	515 003 40	1	Vergaserdüse	Nozzle
			weitere Rohrverschraubungen s. EL-Blatt 90-9998, Anhang	further unions see page 90-9998, annex
			Rohre s. EL-Blatt 90-9959, Anhang	Pipes see page 90-9959, annex
			Rohrschellen s. EL-Blatt 90-9995, Anhang	Pipe clamps see page 90-9995, annex

**Hydr. Hubwerk II**  
**Hydr. Hoist II**

**123-1861b**

Seite/Page 6 / 6