

**124-1045**

Seite/Page 1 / 4

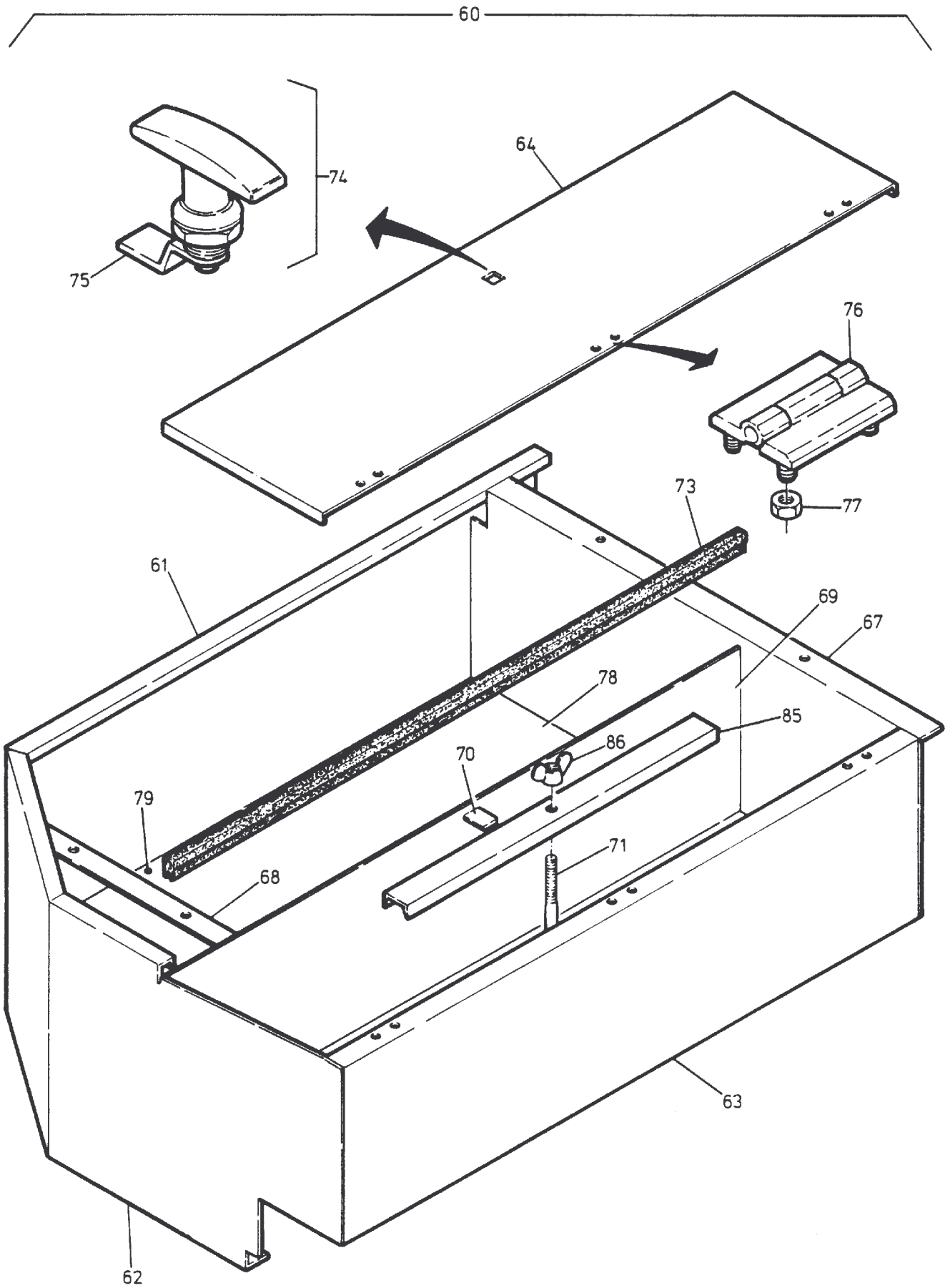

**124-1045**

Seite/Page 2 / 4

Bild-Nr Fig Fig Fig Fig Bild nr	ET-Nr Part-No No. de Piece No. de Pieza No. del Pezzo Detalj nr	Stückzahl Qty Qte Ctd Qta Antal	Gegenstand Description Designation Descripcion Designazione Benaemning
--	--	--	---

			<b>Bild 1</b>	<b>Graphic 1</b>
01	393 635 40	1	Gerätekasten, kpl. einschl. Bild-Nr. 02-06	Tool box, assy., incl. fig-nos: 02-06
02	*	-	Dichtprofil 1,5m	Profiled joint
03	360 822 40	1	Knebelgriff	T-handle
04	360 823 40	1	Zunge	Tab
05	348 659 40	3	Scharnier	Hinge
06	334 690 99	12	Mutter	Nut
-	408 906 40	1	Streckgitter	Screen
-	469 860 40	2	Kabelrohr ø 35	Cable conduit
07	308 585 99	4	Schraube	Bolt
08	346 500 99	8	Federring	Lock washer
09	332 113 99	8	Mutter	Nut
10	367 846 40	1	Kühlerverkleidung	Radiator cowl
11	307 750 99	22	Schraube	Bolt
12	346 510 99	28	Federring	Lock washer
13	348 635 40	16	Blindniet-Mutter	Blind rivet nut
14	*		Compriband 3m	Tape
15	393 590 40	1	Platte	Plate
16	320 821 99	3	Schraube	Screw
17	343 176 99	3	Federscheibe	Lock washer
18	332 110 99	3	Mutter	Nut
19	318 397 99	2	Schraube	Bolt
20	367 825 40	1	Seitenwand, kpl. einschl. Bild-Nr. 21-27	Side panel, assy. incl. fig-nos: 21-27
21	327 924 40	2	Zapfen	Pivot
22	332 351 99	2	Mutter	Nut
23	393 498 40	3	Zwischenstück	Extension
24	180 206 40	3	Federriegel	Twist lock
25	501 528 98	6	Schraube	Screw
26	180 710 40	6	Scheibe	Disk
27	332 110 99	6	Mutter	Nut
28	393 532 40	1	Verkleidung, hinten	Covering, rear
29	307 754 99	11	Schraube	Bolt
30	367 840 40	1	Deckel, kpl. einschl. Bild-Nr. 31+32	Cover, assy. incl. fig-nos: 31+32
31	360 822 40	1	Knebelgriff	T-handle
32	360 823 40	1	Zunge	Tab
33	367 835 40	1	Strebe	Brace
34	*		Dichtprofil	Profiled joint

**Verkleidungsteile, rechts  
Covering Parts, R.H.**

**124-1045**

Seite/Page 3 / 4

<b>Bild-Nr</b> Fig Fig Fig Bild nr	<b>ET-Nr</b> Part-No No. de Piece No. de Pieza No. del Pezzo Detalj nr	<b>Stückzahl</b> Qty Qte Ctd Qta Antal		<b>Gegenstand</b> Description Designation Descripcion Designazione Benaemning
35	300 761 40	1	Gasfeder	Pneumatic spring
36	334 681 99	1	Mutter	Nut
37	334 301 99	1	Bolzen	Pin
38	340 464 99	1	Scheibe	Washer
39	342 035 99	1	Splint	Cotter pin
40	393 499 40	1	Abdeckung	Covering
41	332 111 99	3	Mutter	Nut
42	360 821 40	3	Scharnier	Hinge
			<b>Bild 2</b>	<b>Graphic 2</b>
			<b>Gerätekasten für Batterie 210 Ah</b>	<b>Tool box for battery 210 Ah</b>
60	458 114 40	1	Werkzeugkasten, kpl. (best. aus Bild-Nr. 61-79)	Tool box assy. (consist. of fig-nos: 61-79)
61	393 636 40	1	Seitenwand	Side panel
62	458 167 40	1	Blech	Plate
63	458 112 40	1	Blech	Plate
64	458 113 40	1	Deckel	Cover
67	458 168 40	1	Seitenblech	Side plate
68	458 154 40	1	Flansch	Flange
69	458 110 40	1	Blech	Plate
70	393 645 40	1	Zunge	Tab
71	458 111 40	1	Gewindestange	Threaded rod
72	393 652 40	1	Blech	Plate
73	*	-	Dichtprofil	Profiled joint
74	360 822 40	1	Knebelgriff kpl. mit Zunge	T-handle assy. with tab
75	360 823 40	1	Zunge, alleine	Tab, separate
76	348 659 40	3	Scharnier	Hinge
77	334 690 99	12	Mutter	Nut
78	458 160 40	1	Bodenblech	Bottom plate
79	360 825 40	15	Niet	Rivet
85	408 179 40	1	Batteriehalter	Battery bracket
86	338 013 99	1	Flügelmutter	Wing nut
			* Meterware, bei Bestellung Länge angeben	* Bulk ware, state length required
-	255 256 40		Compriband 60x30	Tape
-	360 824 40	-	Dichtprofil	Profiled joint

**Verkleidungsteile, rechts**  
**Covering Parts, R.H.**

**124-1045**

Seite/Page 4 / 4