

00

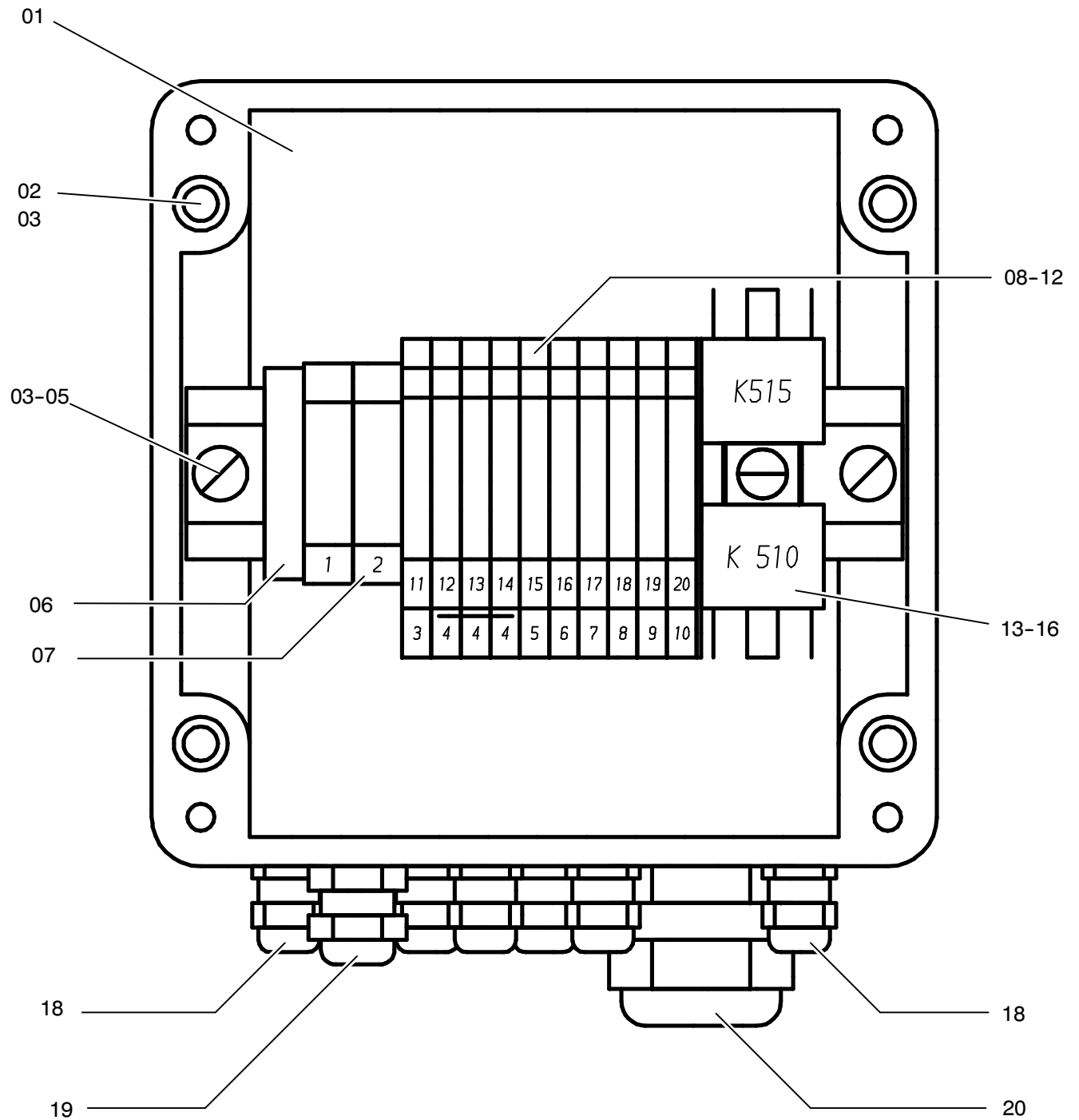

124-2232a

Seite/Page 1 / 2

Bild-Nr Fig Fig Fig Fig Bild nr	ET-Nr Part-No No. de Piece No. de Pieza No. del Pezzo Detalj nr	Stückzahl Qty Qte Ctd Qta Antal		Gegenstand Description Designation Descripcion Designazione Benaemning
00	633 246 40	1	Verteilerkasten	Distribution box
01	270 344 40	1	Leergehäuse	Housing, empty
02	321 015 99	3	Zylinderschraube	Screw
03	346 499 99	5	Federring	Lock washer
04	632 318 40	1	Tragschiene	Assembly rail
05	320 819 99	2	Zylinderschraube	Screw
06	356 265 40	1	Endklammer	Clamp
07	356 274 40	2	Reihenklammer	Serial terminal
08	356 264 40	10	Doppelstockklammer	Twin terminal
09	356 266 40	1	Abschlußplatte	Cover plate
10	356 268 40	1	Querverbinder	Cross connection
11	356 281 40	1	Bezeichnungskarte 1-10	Marker 1-10
12	356 282 40	1	Bezeichnungskarte 11-20	Marker 11-20
13	180 221 40	2	Schaltrelais, 24V	Switching relay
14	324 068 40	1	Tragsockel	Supporting trestle
15	320 816 99	1	Zylinderschraube	Screw
16	340 461 99	1	Scheibe	Washer
18	323 693 40	9	Kabelverschraubung PG 7	Cable union
19	300 970 40	2	Kabelverschraubung PG 9	Cable union
20	270 250 40	1	Kabelverschraubung PG 21	Cable union

**Verteilerkasten X510
Distribution Box X510**

124-2232a

Seite/Page 2 / 2