

22
23
31

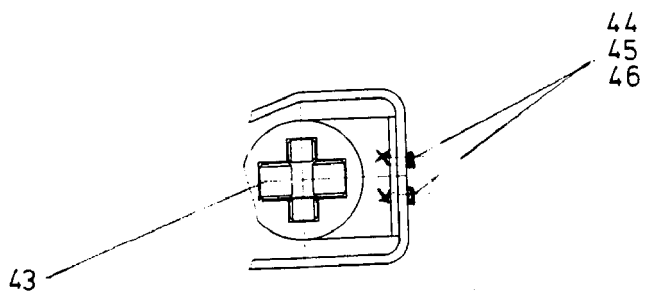

124-6199

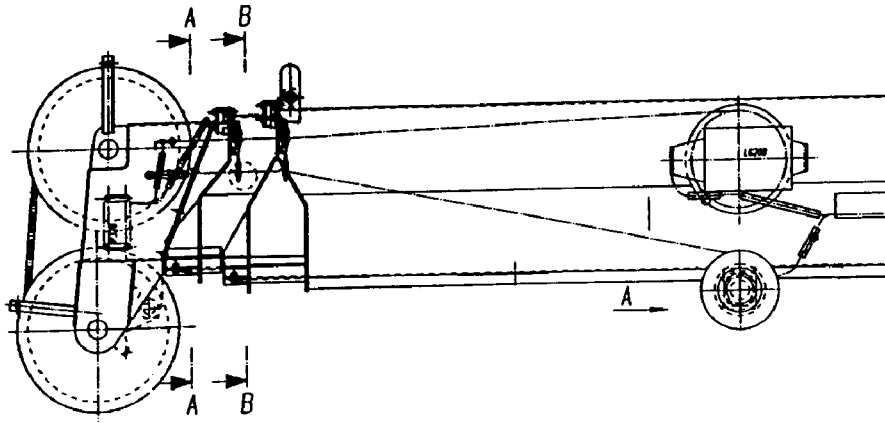

Ansicht A

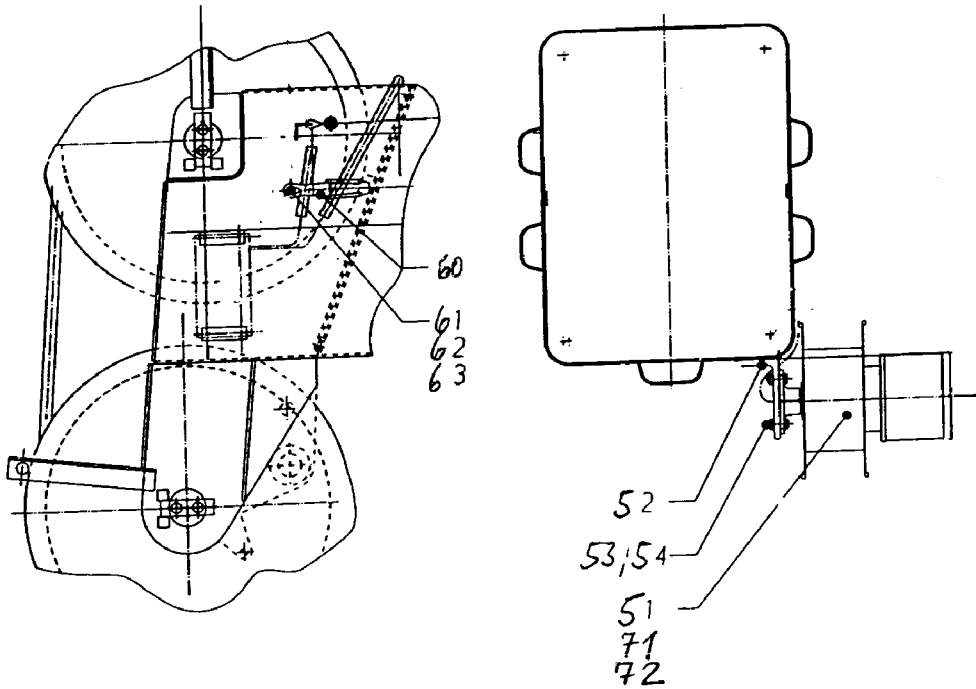

Schnitt A-A

Schnitt B-B

Einzelheit X
M 1:2.5

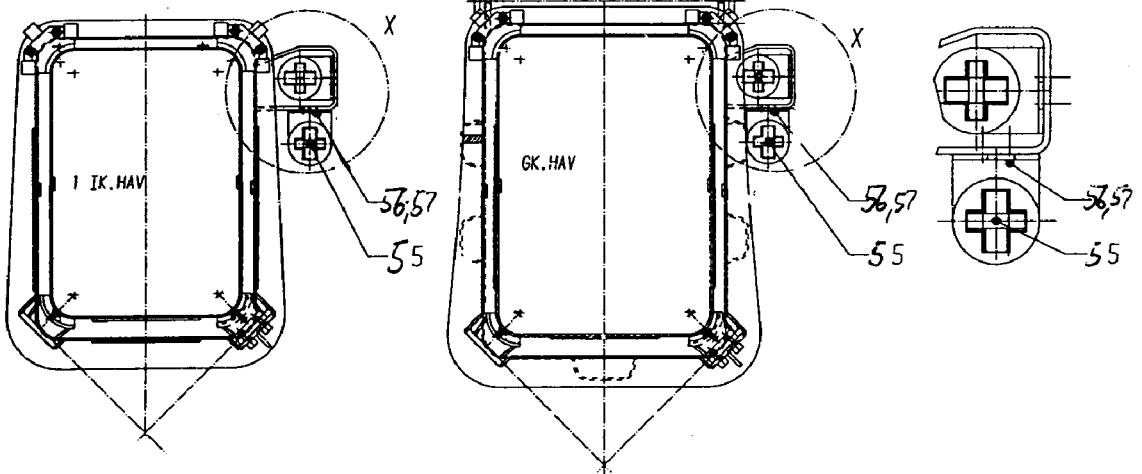

124-6199

Bild-Nr Fig Fig Fig Fig Bild nr	ET-Nr Part-No No. de Piece No. de Pieza No. del Pezzo Detailj nr	Stückzahl Qty Qte Ctd Qta Antal		Gegenstand Description Designation Descripcion Designazione Benaemning
			Bild 1	Graphic 2
01	455 020 40	1	Verteilerkasten - Telekopf	Distribution box, boom head
02	455 577 40	1	Verteilerkasten - Telewippe	Distribution box, luffer
03	455 681 40	1	Kabel - Steuerung	Cable, control
04	455 679 40	1	Kabel - LMB	Cable, load limit device
05	551 796 40	1	Längenwinkelgeber	Longitudinal angle transmitter
06	300 981 40	1	Kabelverschraubung	Cable union
07	414 524 40	1	Reduktion	Reduction
08	461 912 40	1	Widerstand	Resistor
09	*	-	Kabel, 3-pol.	Cable
10	*	-	Schlauch	Hose
11	007 625 98	4	Schelle	Clamp
12	320 821 99	4	Zylinderschraube	Bolt
13	340 463 99	4	Scheibe	Disc
15	515 210 40	4	Kabel kpl.	Cable, assy.
16	551 797 40	1	Winkelgeber	Angle transmitter
17	552 116 40	1	Kabel (Winkelgeber-HA-Kopf)	Cable (angle transmitter - main boom head)
21	490 352 40	2	Leuchtdruckschalter	Luminous push switch
22	368 046 40	3	Druckhaube, weiß	Push hood, white
23	356 156 40	3	Glühlampe	Bulb
-	454 882 40	1	Symbolfolie	Symbolic foil
			Zusatzelektrik Verbolzung	Auxiliary electric pin locking
31	368 045 40	1	Leuchtdruckschalter	Luminous push switch
-	461 373 40	1	Steckverbinder	Connector
-	461 372 40	1	Dichtung	Gasket
-	323 693 40	1	Kabelverschraubung	Cable union
-	414 522 40	1	Reduzierung	Reduction
-	*	-	Kabel, 3-pol.	Cable
			Kabelführung	Feeder cable
43	270 875 40	2	Rollenmundstück	Roller adapter
44	307 754 99	4	Schraube	Bolt
45	343 108 99	4	Federring	Lock washer
46	332 111 99	4	Mutter	Nut
			* Meterware, bei Bestellung Länge angeben	* Bulk ware, state length required
*	369 198 40	-	Kabel, 3-pol.	Cable
*	160 389 40	-	Schlauch (Schutzschlauch)	Hose (protective hose)
			Bild 2	Graphic 2
			Kundenwunsch	Optional equipment
			Anbau Windmesser u. Flugsicherungsleuchte	Installation wind meter and aerodynamical safety light
51	581 672 40	1	Kabeltrommel kpl.	Cable drum assy.
Elektrik			124-6199	
Electric			Seite/Page 3/4	

Bild-Nr Fig Fig Fig Fig Bild nr	ET-Nr Part-No No. de Piece No. de Pieza No. del Pezzo Detailj nr	Stückzahl Qty Qte Ctd Qta Antal		Gegenstand Description Designation Descripcion Designazione Benaemning
52	581 671 40	1	Halter	Retainer
53	502 388 98	4	Schraube	Bolt
54	332 114 99	4	Mutter	Nut
55	270 875 40	2	Leitungsführung	Lead guide
56	307 752 99	4	Schraube	Bolt
57	332 332 99	4	Mutter	Nut
60	181 462 40	1	Abspannklemme	Clamp
61	581 693 40	1	Festpunkt	Fixed point
62	340 470 99	2	Scheibe	Disc
63	342 061 99	2	Splint	Cotter pin
64	*	-	Kabel 8-pol.	Cable
71	592 468 40	1	Kabeltrommel	Cable drum
72	*	-	Kabel 7-pol.	Cable
			* Meterware, bei Bestellung Länge angeben	* Bulk ware, state length required
*	369 538 40	-	Kabel 8-pol.	Cable
*	592 344 40	-	Kabel 7-pol.	Cable