

00

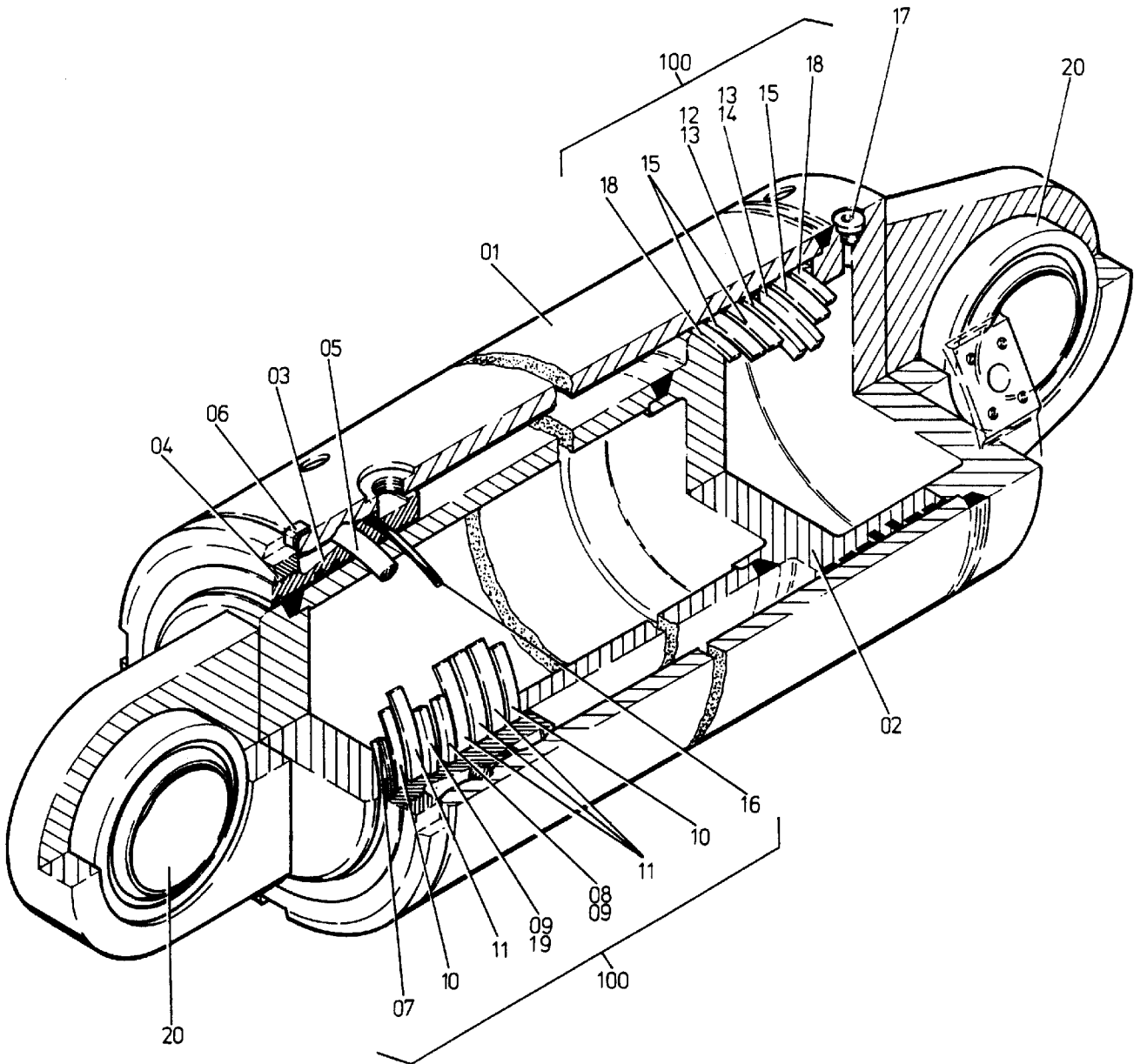

130-1016

Seite/Page 1 / 2

Bild-Nr Fig Fig Fig Fig Bild nr	ET-Nr Part-No No. de Piece No. de Pieza No. del Pezzo Detalj nr	Stückzahl Qty Qte Ctd Qta Antal		Gegenstand Description Designation Descripcion Designazione Benaemning
00	456 445 40	1	Wippzylinder kpl.	Derricking cylinder assy.
01	462 611 40	1	Zylinderrohr	Cylinder barrel
02	462 612 40	1	Kolbenstange	Piston rod
03	246 273 40	1	Zylinderkopf	Cylinder head
04	246 285 40	1	Nutmutter	Groove nut
05	246 284 40	1	Haltering	Retaining ring
06	246 283 40	1	Sicherung	Fuse
07	256 907 40	1	Abstreifer	Scraper
08	256 908 40	1	Turcon-Stepseal	Turcon-stepseal
09	202 703 40	2	O-Ring	O-ring
10	256 909 40	2	Führungsband	Guide strap
11	356 132 40	4	Stangenführungsring	Rod guide ring
12	414 109 40	1	Glyd-Ring	Glyd-ring
13	256 912 40	2	O-Ring	O-ring
14	256 913 40	1	Turcon-Stepseal	Turcon-stepseal
15	256 915 40	3	Kolbenführungsring	Piston guide ring
16	256 882 40	1	O-Ring	O-ring
17	171 260 40	2	Verschlussschraube	Plug
18	256 914 40	2	Führungsband	Guide strap
19	324 699 40	1	Stepseal	Stepseal
20	461 145 40	2	Gelenklager	Swing support
100	780 073 73	1	Dichtsatz best. aus Bild-Nr. 07-16, 18 u. 19	Seal kit consist. of fig-nos: 07-16, 18 and 19

**Wippzylinder
Derricking Cylinder**

130-1016

Seite/Page 2 / 2