

00

Anordnung des Drehzahlgebers am Kurbelwellengehäuse

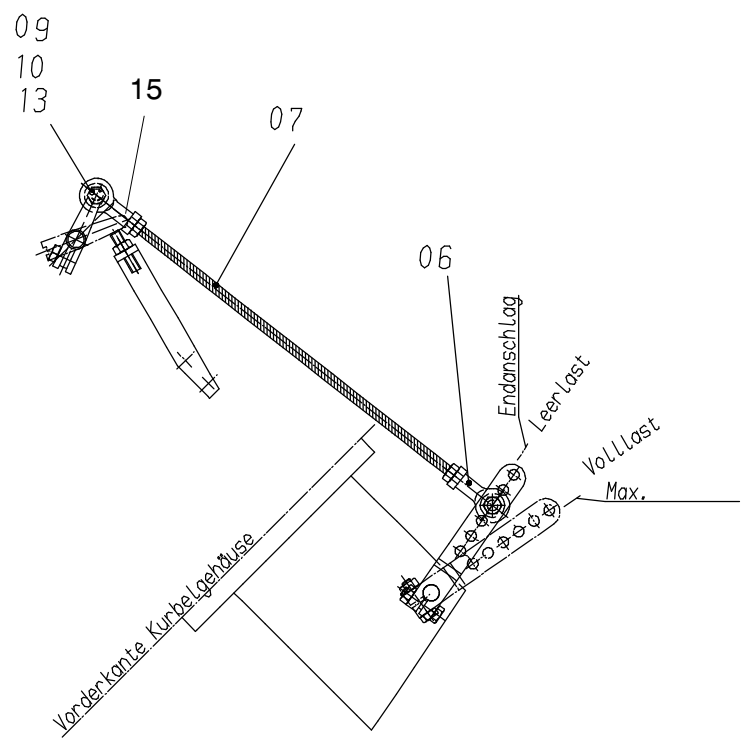
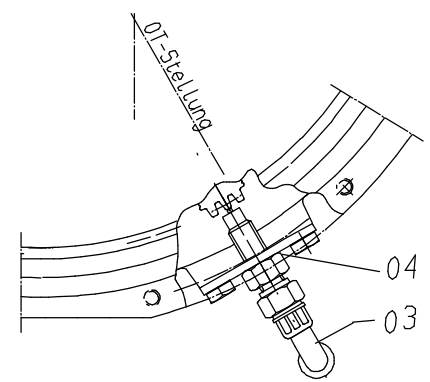

Bild-Nr Fig Fig Fig Fig Bild nr	ET-Nr Part-No No. de Piece No. de Pieza No. del Pezzo Detalj nr	Stückzahl Qty Qte Ctd Qta Antal		Gegenstand Description Designation Descripcion Designazione Benaemning
00	628 587 40	1	Drehzahlregulierung kpl.	Speed control assy.
01	634 793 40	1	Stellglied	Reset
02	628 817 40	1	Blech	Plate
03	634 794 40	1	Drehzahlaufnehmer	RPM pick-up
04	634 795 40	1	Halter	Retainer
05	628 868 40	1	Blech	Plate
06	634 845 40	2	Gelenkkopf	Knuckle
07	628 869 40	1	Gewindestange	Threaded rod
08	501 935 98	2	Schraube	Bolt
09	307 730 99	2	Schraube	Bolt
10	320 068 99	4	Mutter	Nut
11	319 241 99	2	Schraube	Screw
12	340 464 99	2	Scheibe	Washer
13	340 683 99	2	Scheibe	Washer
14	319 147 99	2	Schraube	Bolt
15	300 257 99	1	Winkel	Angle

**Drehzahlregulierung
Speed Control**

157-1270

Seite/Page 2 / 2