

Schnitt B - B

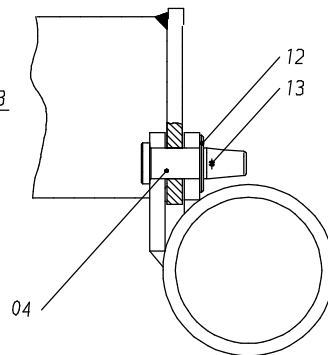

157-1450a

Seite/Page 1 / 3

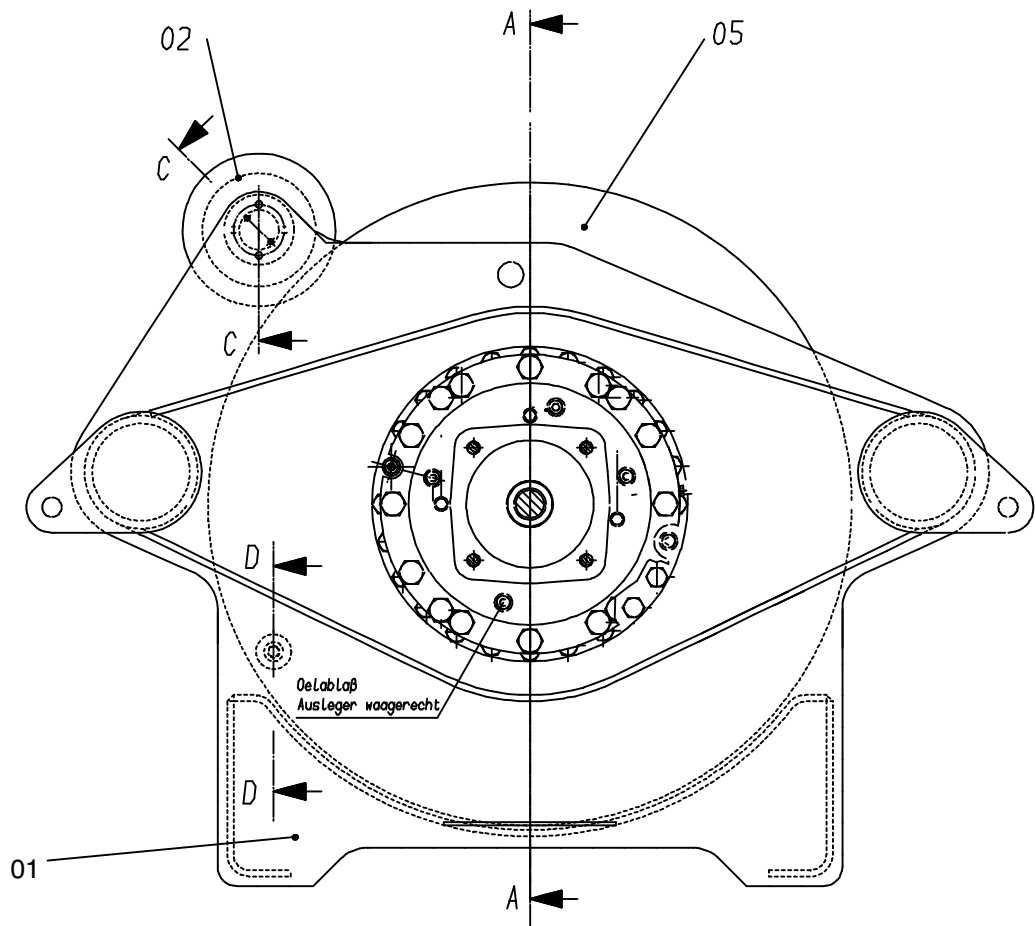

Schnitt C - C

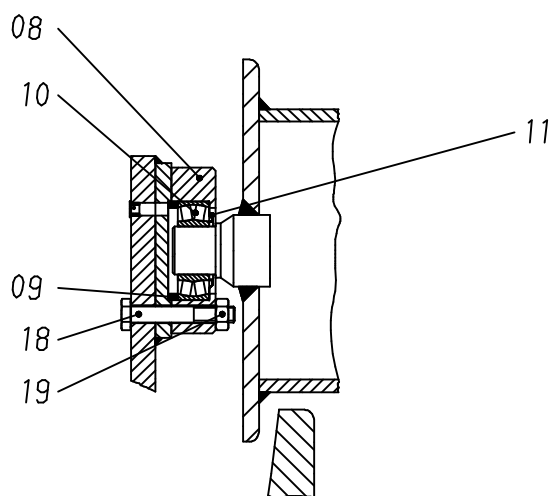

Schnitt D - D

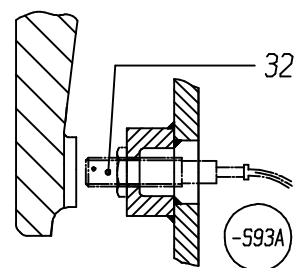

157-1450a

Bild-Nr Fig Fig Fig Fig Bild nr	ET-Nr Part-No No. de Piece No. de Pieza No. del Pezzo Detalj nr	Stückzahl Qty Qte Ctd Qta Antal		Gegenstand Description Designation Descripcion Designazione Benaemning
00	630 730 40	1	Winde	Winch
01	628 650 40	1	Windenrahmen, SK	Winch frame
02	628 648 40	1	Walze	Roll
03	628 649 40	1	Schutzhaube	Protecting hood
04	628 720 40	4	Bolzen	Pin
06	-	1	Senkendschalter s. EL-Blatt 52-1325	Lower limit switch see page 52-1325
07	-	1	Konstantmotor s. EL-Blatt 993-0346	Fixed displacement motor see page 993-0346
08	497 152 40	2	Deckel	Cover
09	497 153 40	2	Ring	Ring
10	360 737 99	2	Pendelrollenlager	Self-aligning bearing
11	005 268 98	2	Wellendichtring	Shaft seal
12	340 472 99	4	Scheibe	Washer
13	001 644 98	4	Sicherungsfeder	Locking spring
14	319 338 99	16	Schraube	Bolt
15	500 333 98	4	Schraube	Bolt
16	307 454 99	6	Schraube	Bolt
17	307 615 99	12	Schraube	Bolt
18	308 624 99	8	Schraube	Bolt
19	332 113 99	8	Mutter	Nut
20	307 777 99	4	Schraube	Bolt
21	-	1	Hydr. für Wippwerk 1 s. EL-Blatt 157-1460	Hydr. for luffing gear 1 see page 157-1460
31	-	1	Verteilerkasten W1-W2 s. EL-Blatt 157-1470	Distribution box see page 157-1470
32	604 434 40	1	Näherungsschalter	Switch
41	630 628 40	1	Seiltrommel	Rope drum
42	-	1	Windengetriebe s. EL-Blatt 90-3551	Hoist gear see page 90-3551
43	308 885 99	24	Schraube	Bolt

**Winde W1
Winch W1**

157-1450a

Seite/Page 3 / 3