

**157-1485a**

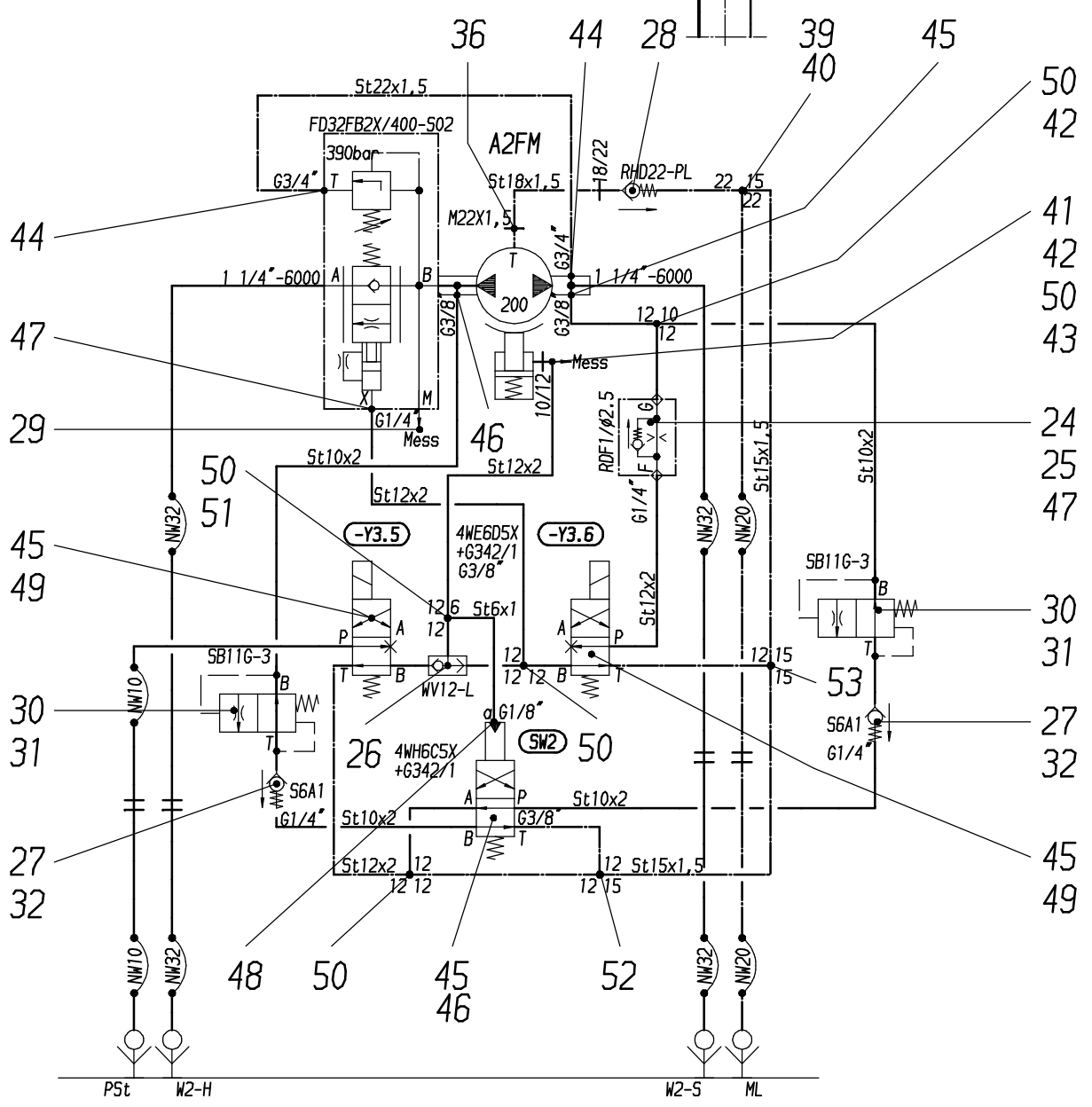
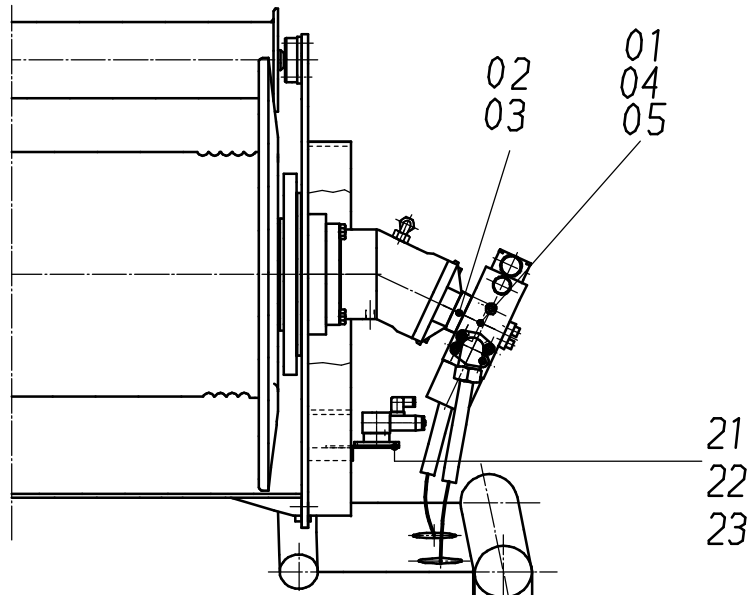

**157-1485a**

Bild-Nr Fig Fig Fig Fig Bild nr	ET-Nr Part-No No. de Piece No. de Pieza No. del Pezzo Detalj nr	Stückzahl Qty Qte Ctd Qta Antal		Gegenstand Description Designation Descripción Designazione Benaemning
01	551 466 40	1	Serr-Q-Meter	Check-q-meter
02	448 491 40	1	Zwischenplatte	Intermediate plate
03	006 725 98	4	O-Ring	O-ring
04	501 605 98	4	Schraube	Bolt
05	343 866 99	16	Federring	Lock washer
06	662 909 40	1	Zwischenflansch	Intermediate flange
07	320 238 99	4	Schraube	Bolt
08	006 638 98	4	Flansch	Half flange
09	319 209 99	8	Schraube	Bolt
10	551 605 40	2	Kupplungsstecker NW 32	Coupler plug
11	490 799 40	2	Verschlußschraube	Plug
12	551 595 40	1	Kupplungsstecker NW 20	Coupler plug
13	551 597 40	1	Verschlußschraube	Plug
14	567 072 40	1	Kupplungsstecker NW 10	Coupler plug
15	551 589 40	1	Verschlußschraube	Plug
16	226 959 40	2	4/2-Wege-Magnetventil	4/2-Directional spool valve
17	180 325 40	3	Grundplatte	Base plate
18	319 174 99	12	Schraube	Screw
19	343 852 99	12	Federring	Lock washer
20	346 512 40	1	Wegeventil	Directional spool valve
21	307 408 99	6	Schraube	Bolt
22	332 110 99	6	Mutter	Nut
23	343 853 99	6	Federring	Lock washer
24	226 480 40	1	Rückschlagventil	Non-return valve
25	270 825 40	1	Vergaserdüse	Nozzle
26	256 977 40	1	Wechselventil	Shuttle valve
27	210 906 40	2	Sperrventil	Non-return valve
28	634 360 40	1	Stutzen	Socket
29	153 646 40	1	Kupplung	Coupling
30	635 637 40	2	Stromregelventil	Flow control valve
31	634 490 40	4	Stutzen	Socket
32	551 349 40	4	Stutzen	Socket
33	635 804 40	2	Stutzen	Socket
34	509 592 98	1	Stutzen	Socket
35	634 255 40	1	Stutzen	Socket
36	576 442 40	1	Stutzen	Socket
37	576 438 40	2	Stutzen	Socket
38	551 404 40	1	Stutzen	Socket
39	576 469 40	1	Stutzen	Socket
40	551 483 40	1	Verschraubung	Union

**Hydr. Wippwerk 2**  
**Hydr. Luffing Gear 2**

**157-1485a**

Seite/Page 3 / 5

Bild-Nr Fig Fig Fig Fig Bild nr	ET-Nr Part-No No. de Piece No. de Pieza No. del Pezzo Detalj nr	Stückzahl Qty Qte Ctd Qta Antal		Gegenstand Description Designation Descripcion Designazione Benaemning
41	551 616 40	1	Stutzen	Socket
42	551 379 40	2	Stutzen	Socket
43	502 752 98	1	Stutzen	Socket
44	551 306 40	2	Stutzen	Socket
45	592 135 40	9	Stutzen	Socket
46	621 788 40	3	Stutzen	Socket
47	634 393 40	3	Stutzen	Socket
48	551 634 40	1	Stutzen	Socket
49	255 694 40	2	Verschlußschraube	Plug
50	511 015 98	5	Stutzen	Socket
51	551 378 40	1	Stutzen	Socket
52	592 325 40	1	Stutzen	Socket
53	551 991 40	1	Stutzen	Socket
54	646 294 40	1	Halter	Retainer
55	527 473 40	1	Schlauchleitung 4SP 32x2850	Hose assy.
56	646 242 40	1	Schlauchleitung 2SN 32x3000	Hose assy.
57	255 455 40	1	Schlauchleitung 1SN 20x3100	Hose assy.
58	369 308 40	1	Schlauchleitung 1SN 10x3200	Hose assy.
59	256 379 40	1	Schlauchleitung 1SN 10x1750	Hose assy.
60	182 495 40	1	Schlauchleitung 1SN 20x2300	Hose assy.
61	160 355 40	1	Schlauchleitung 2SN 32x2000	Hose assy.
62	285 978 40	1	Schlauchleitung 4SP 32x1500	Hose assy.
68	551 480 40	2	Stutzen	Socket
-	510 017 98		Überwurfmutter AL22	Union nut
-	371 274 99		Überwurfmutter AL12	Union nut
-	371 273 99		Überwurfmutter AL10	Union nut
-	371 271 99		Überwurfmutter AL6	Union nut
-	371 258 99		Überwurfmutter AS10	Union nut
-	371 244 99		Schneidring L22	Olive
-	371 241 99		Schneidring L12	Olive
-	371 240 99		Schneidring L10	Olive
-	371 238 99		Schneidring L6	Olive
-	371 255 99		Schneidring S10	Olive
-	371 259 99		Überwurfmutter AS12	Union nut
-	371 510 99		Schneidring S12	Olive
-	*	-	Rohr 18	Pipe
-	*	-	Rohr 22	Pipe
-	*	-	Rohr 12	Pipe
-	*	-	Rohr 15	Pipe
			* Meterware, bei Bestellung Länge angeben	* Bulk ware, state length required
*	215 812 99	-	Rohr 18	Pipe

Hydr. Wippwerk 2  
Hydr. Luffing Gear 2

157-1485a

Seite/Page 4 / 5

Bild-Nr Fig Fig Fig Fig Bild nr	ET-Nr Part-No No. de Piece No. de Pieza No. del Pezzo Detalj nr	Stückzahl Qty Qte Ctd Qta Antal		Gegenstand Description Designation Descripcion Designazione Benaemning
*	215 495 99	-	Rohr 22	Pipe
*	215 642 99	-	Rohr 12	Pipe
*	215 811 99	-	Rohr 15	Pipe