

Schnitt C-C

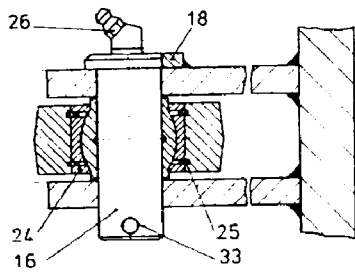

Schnitt E-E

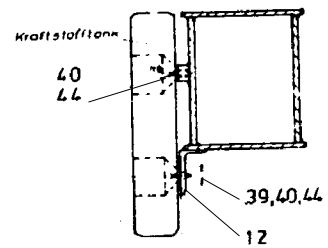

Schnitt B-B

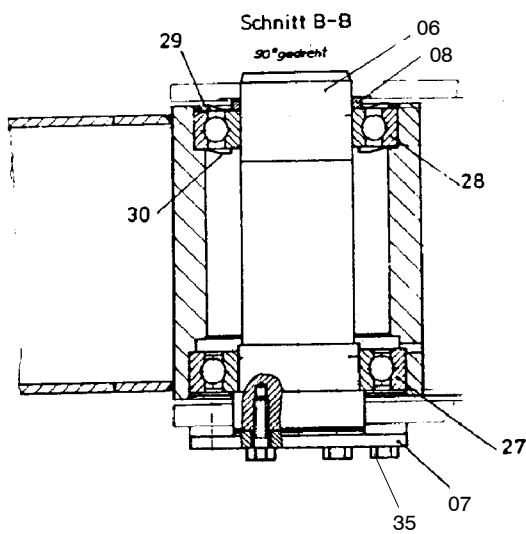

Einzelheit „Z“

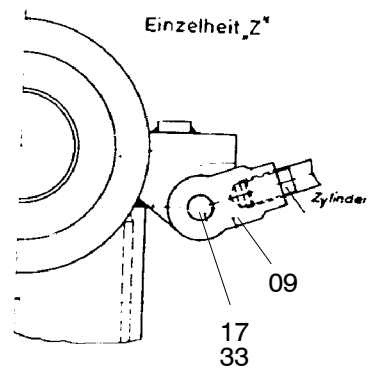

Bild-Nr Fig Fig Fig Fig Bild nr	ET-Nr Part-No No. de Piece No. de Pieza No. del Pezzo Detalj nr	Stückzahl Qty Qte Ctd Qta Antal		Gegenstand Description Designation Descripcion Designazione Benaemning
01	-	1	Kabineninstallation s. EL-Blatt 157-1920	Cabin installation see page 157-1920
02	637 603 40	1	Kabinenrahmen	Cab frame-support
03	637 770 40	1	Schwenkarm	Swinging arm
04	637 702 40	1	Außenpodest	Outer stage
05	637 632 40	1	Geländer kpl.	Rail assy.
06	637 654 40	1	Bolzen	Pin
07	498 587 40	1	Deckel	Cover
08	498 588 40	1	Ring	Ring
09	498 532 40	1	Auge	Eye
10	637 633 40	1	Blech	Plate
12	637 657 40	2	Blech	Plate
13	637 658 40	1	Bolzen	Pin
14	637 659 40	1	Bolzen	Pin
15	637 660 40	2	Bolzen	Pin
16	574 225 40	1	Bolzen	Pin
17	498 590 40	1	Bolzen	Pin
18	498 591 40	1	Blech	Plate
20	515 420 40	1	Sicherungsbolzen kpl.	Lock pin assy.
21	-	1	Arbeitszylinder s. EL-Blatt 90-0881	Slave cylinder see page 90-0881
22	634 756 40	1	Hydr.-Zylinder	Hydr. cylinder
23	635 212 40	1	Sicherheitsrost	Safety grating
24	226 911 40	1	Gelenklager	Swing support
25	001 527 98	2	Sprengring	Snap ring
26	350 564 99	1	Schmiernippel	Grease nipple
27	507 013 98	1	Rillenkugellager	Roller bearing
28	360 571 99	1	Rillenkugellager	Roller bearing
29	005 013 98	1	Wellendichtring	Shaft seal
30	507 095 98	1	Wellendichtring	Shaft seal
31	340 619 99	2	Scheibe	Washer
32	340 623 99	2	Scheibe	Washer
33	342 101 99	2	Splint	Cotter pin
34	342 121 99	4	Splint	Cotter pin
35	307 612 99	14	Schraube	Bolt
36	307 804 99	15	Schraube	Bolt
37	307 425 99	10	Schraube	Bolt
38	332 113 99	8	Mutter	Nut
39	332 111 99	12	Mutter	Nut
40	340 507 99	19	Scheibe	Washer
41	550 462 40	1	Bügel	Yoke

Bild-Nr Fig Fig Fig Fig Bild nr	ET-Nr Part-No No. de Piece No. de Pieza No. del Pezzo Detalj nr	Stückzahl Qty Qte Ctd Qta Antal		Gegenstand Description Designation Descripcion Designazione Benaemning
42	550 464 40	1	Platte	Plate
43	550 465 40	1	Halter	Retainer
44	207 593 40	9	Schraube	Bolt
45	307 777 99	8	Schraube	Bolt
46	504 207 98	2	Schraube	Bolt
47	313 500 99	1	Ringschraube	Eyebolt
48	504 212 98	1	Mutter	Nut
49	414 398 40	2	Blindniet-Mutter	Blind-rivet nut
50	350 763 99	2	Scheibe	Washer
51	307 631 99	4	Schraube	Bolt
52	*	-	Kabelrinne	Cable guide
53	*	-	Deckel	Cover
54	515 613 40	2	Bodenendblech	Bottom end plate
55	637 662 40	1	Leiter	Ladder
56	500 623 98	9	Schraube	Bolt
57	870 666 40	1	Perlon-Schnur Ø 8x3,2 m	Ribbon
58	500 813 98	6	Schraube	Bolt
-	180 893 40	1	Feuerlöscher	Fire extinguisher
71	637 634 40	1	Pendeltür	Swing door
72	637 635 40	1	Pendeltür	Swing door
73	604 756 40	4	Türband	Door strap
			* Meterware, bei Bestellung Länge angeben	* Bulk ware, state length required
*	515 610 40	-	Kabelrinne	Cable guide
*	515 611 40	-	Deckel	Cover