

00

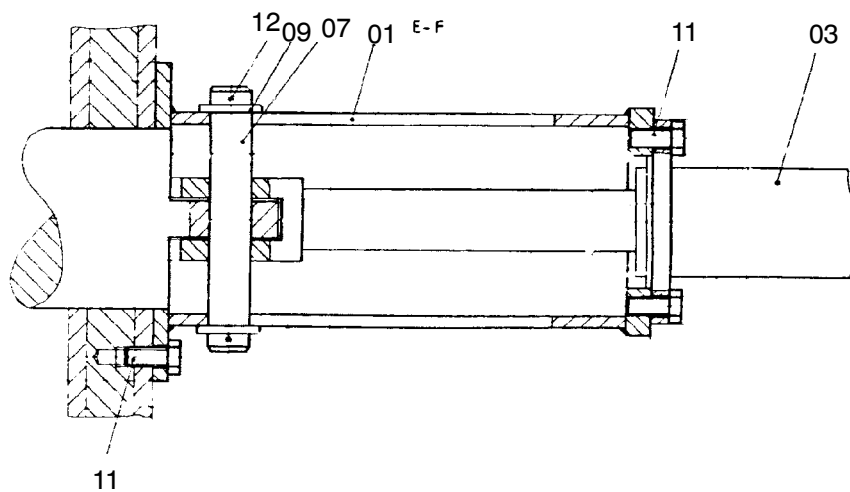
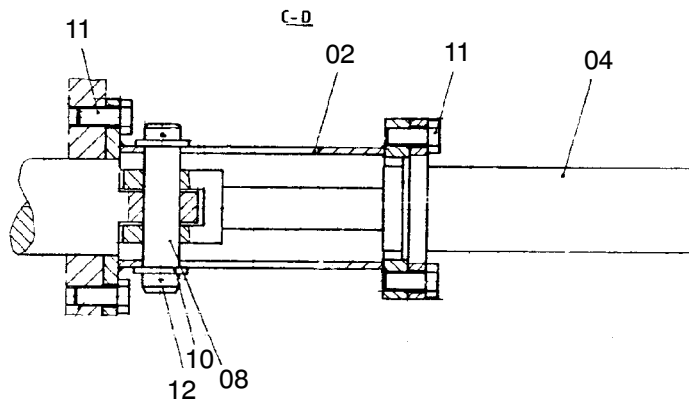
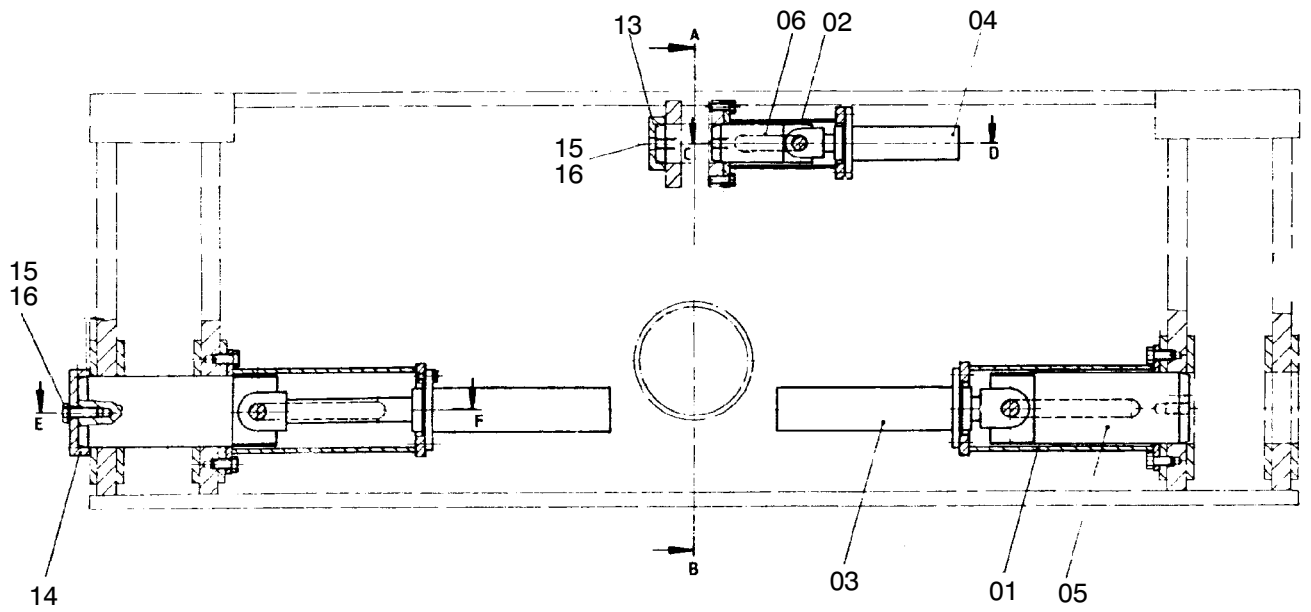

157-3108

Seite/Page 1 / 2

Bild-Nr Fig Fig Fig Fig Bild nr	ET-Nr Part-No No. de Piece No. de Pieza No. del Pezzo Detalj nr	Stückzahl Qty Qte Ctd Qta Antal		Gegenstand Description Designation Descripcion Designazione Benaemning
00	619 293 40	1	Verriegelung kpl.	Locking assy.
01	619 298 40	4	Lagerkörper unten	Bearing cup lower
02	619 299 40	2	Lagerkörper oben	Bearing cup top
03	619 294 40	4	Hydraulikzylinder	Hydraulic cylinder
-	439 141 73		Dichtsatz zu Bild-Nr. 03	Seal kit to fig-no. 03
04	619 295 40	2	Hydraulikzylinder	Hydraulic cylinder
-	439 142 73		Dichtsatz zu Bild-Nr. 04	Seal kit to fig-no. 04
05	619 296 40	4	Bolzen	Pin
06	619 297 40	2	Bolzen	Pin
07	511 285 98	4	Bolzen	Pin
08	511 271 98	2	Bolzen	Pin
09	340 623 99	8	Scheibe	Washer
10	340 619 99	4	Scheibe	Washer
11	307 823 99	72	Stutzen	Socket
12	342 121 99	12	Splint	Cotter pin
13	656 402 40	2	Scheibe	Washer
14	656 403 40	4	Scheibe	Washer
15	307 887 99	6	Stutzen	Socket
16	340 610 99	6	Scheibe	Washer

**Verriegelung  
Locking**

**157-3108**

Seite/Page 2 / 2