

Schnitt C-D

Einzelheit "G"

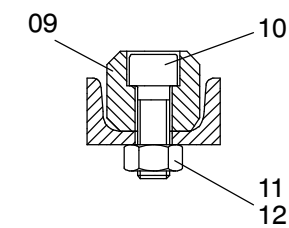

Einzelheit "X"

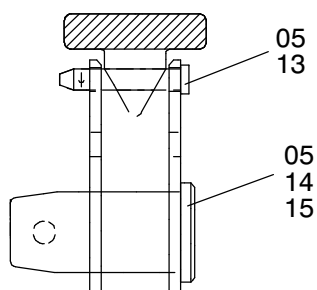
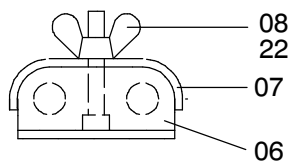

Einzelheit "Z"

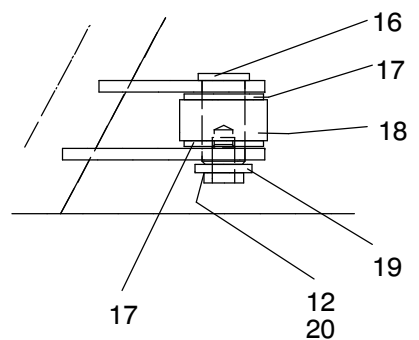

157-6021

Seite/Page 1 / 2

Bild-Nr Fig Fig Fig Fig Bild nr	ET-Nr Part-No No. de Piece No. de Pieza No. del Pezzo Detalj nr	Stückzahl Qty Qte Ctd Qta Antal		Gegenstand Description Designation Descripcion Designazione Benaemning
00	631 610 40	1	6m Zwischenstück kpl. mit Haltestange 6m	6m Extension assy. with stay bar 6m
01	631 600 40	1	6m Zwischenstück SK	6m Extension, weldment
02	622 487 40	2	Haltestange 6m	Stay bar
03	511 716 98	4	Steckbolzen	Socket pin
04	505 908 98	4	Sicherungsbolzen	Lock pin
05	007 266 98	10	Sicherungsfeder	Locking spring
06	654 000 40	4	Gummiteil mit Hülse	Rubber with sleeve
07	654 001 40	4	Bügel	Yoke
08	506 758 99	4	Flügelmutter	Wing nut
09	517 206 40	1	Seilabweiser	Rope deflector
10	319 157 99	3	Schraube	Bolt
11	332 334 99	3	Mutter	Nut
13	622 478 40	4	Bolzen	Pin
14	631 771 40	2	Bolzen	Pin
15	506 640 98	2	Sicherungsbolzen	Lock pin
16	622 479 40	4	Bolzen	Pin
17	340 472 99	8	Scheibe	Washer
18	007 196 98	4	Stützrolle	Roller
19	340 688 99	4	Scheibe	Washer
20	307 360 99	4	Schraube	Bolt
22	340 506 40	12	Scheibe	Washer

**Zwischenstück 6m Typ 2420-10-01  
Extension**

**157-6021**

Seite/Page 2 / 2