

Schnitt A-A

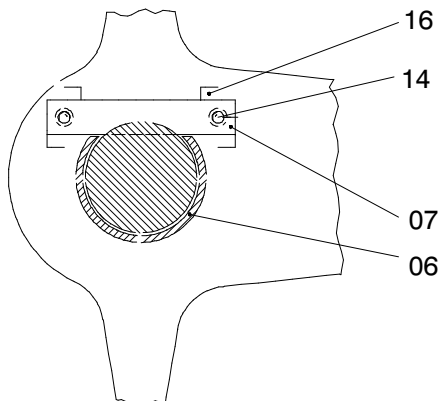

Schnitt B-B

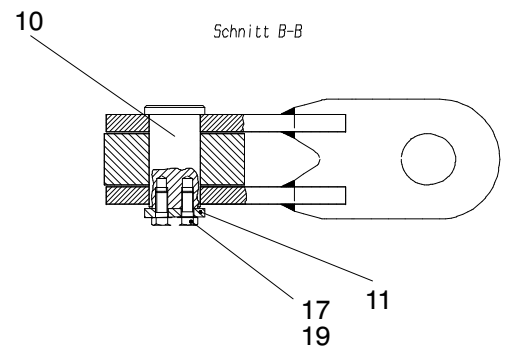

Bild-Nr Fig Fig Fig Fig Bild nr	ET-Nr Part-No No. de Piece No. de Pieza No. del Pezzo Detalj nr	Stückzahl Qty Qte Ctd Qta Antal		Gegenstand Description Designation Descripcion Designazione Benaemning
00	629 000 40	1	Wipptraverse, kpl.	Flying bridle assy.
01	629 002 40	1	Wipptraverse, SK	Flying bridle (weldment)
02	656 055 40	1	Balkentraverse	Bar lifting beam
03	656 057 40	2	Kreuzlasche	Cross bracket
04	629 014 40	1	Achse	Axle
05	629 015 40	2	Deckel	Cover
06	629 016 40	2	Rohrsegment	Tube section
07	629 017 40	2	Achshalter	Axle stirrup
08	292 578 40	1	Bolzen	Pin
09	628 492 40	1	Wellenendscheibe	End plate
10	656 058 40	2	Bolzen	Pin
11	538 629 40	2	Wellenscheibe	Spacer
12	500 817 98	2	Schraube	Bolt
13	631 809 40	6	Seilrolle ø 528, kpl.	Sheave assy.
14	320 412 99	12	Schraube	Bolt
15	460 468 40	2	Ring	Ring
16	487 273 40	8	Knagge	Driver
17	307 601 99	4	Schraube	Bolt
22	005 221 98	6	Zylinderrollenlager	Cylindrical roller bearing
23	505 941 98	12	Sprengring	Snap ring

**Wippseiltraverse
Flying Bridle**

157-6340

Seite/Page 2 / 2