

157-7305

Seite/Page 1 / 3

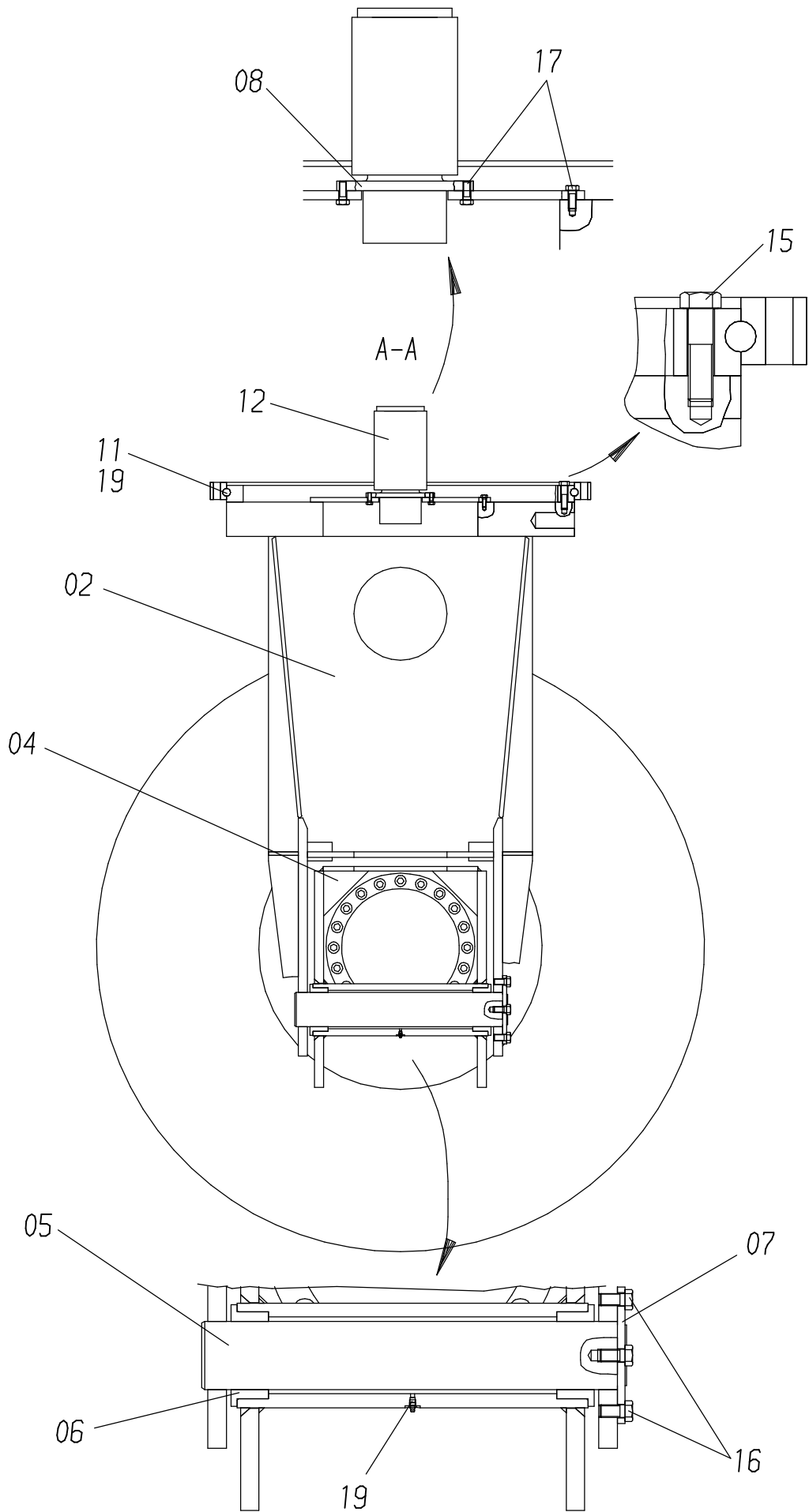

157-7305

Seite/Page 2 / 3

Bild-Nr Fig Fig Fig Fig Bild nr	ET-Nr Part-No No. de Piece No. de Pieza No. del Pezzo Detalj nr	Stückzahl Qty Qte Ctd Qta Antal		Gegenstand Description Designation Descripcion Designazione Benaemning
00	880 952 40	1	Drehschemel, kpl. links	Swivelling bolster waggon, left
02	105 294 12	1	Drehschemel	Swivelling bolster waggon
04	105 296 12	1	Schwinge	Rocker arm
05	880 247 40	1	Achse	Axle
06	880 235 40	2	Buchse	Bushing
07	880 248 40	1	Achshalter	Axle stirrup
08	880 246 40	1	Ring	Ring
09	000 001 12	2	Rad	Wheel
10	000 002 12	2	Fahrgetriebe mit Konstantmotor	Traction transmission with Hydro motor
11	000 003 12	1	Kugeldrehverbindung	Slew ring
12	000 028 12	1	Drehdurchführung	Rotary joint
13	150 927 99	40	Schrauben	Bolt
14	501 110 98	32	Schraube	Bolt
15	308 668 99	36	Schraube	Bolt
16	307 843 99	3	Schraube	Bolt
17	307 804 99	12	Schraube	Bolt
18	316 213 99	32	Scheibe	Washer
19	350 562 99	7	Schmier-Nip	Grease nipple
30	-	2	Fahrgetriebe s. EL-Blatt 993-0414	Traction transmission see page 993-0414
31	-	2	Hydr.-Motor s. EL- Blatt 993-0434	Hydro motor see page 993-0434

**Drehschemel links
Swivelling Bolster Waggon left**

157-7305

Seite/Page 3 / 3