

**168-6214**

Seite/Page 1 / 3

01

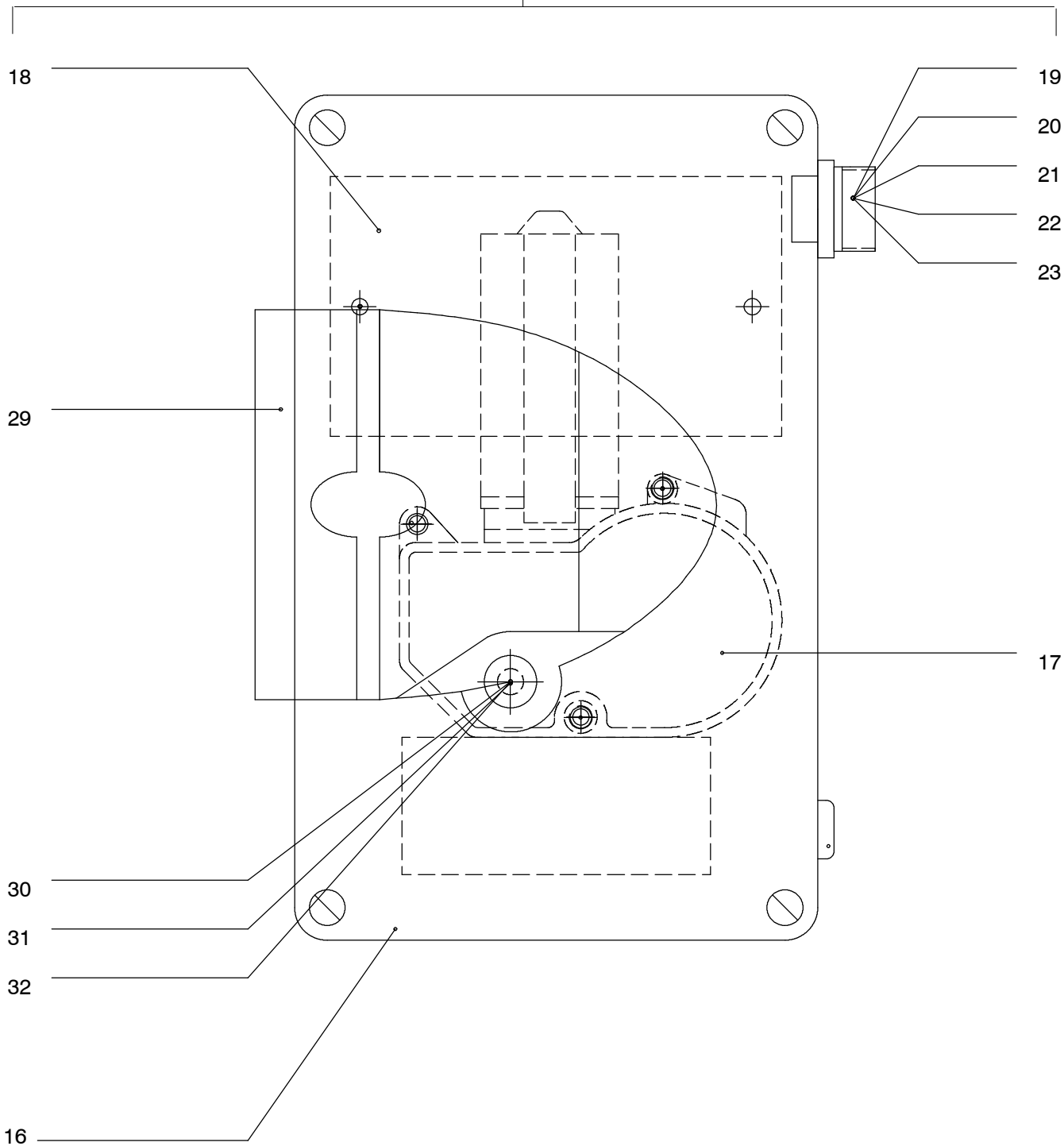

**168-6214**

Seite/Page 2 / 3

<b>Bild-Nr</b> Fig Fig Fig Fig Bild nr	<b>ET-Nr</b> Part-No No. de Piece No. de Pieza No. del Pezzo Detalj nr	<b>Stückzahl</b> Qty Qte Ctd Qta Antal		<b>Gegenstand</b> Description Designation Descripcion Designazione Benaemning
01	163 899 12	1	Verstellscheinwerfer kpl	Spotlight, adjustable
02	509 829 98	2	Schraube	Screw
03	340 509 99	2	Scheibe	Washer
04	130 640 12	1	Arbeitsscheinwerfer kompl.	Spotlight assy.
05	164 225 12	1	Blech	Sheet
06	509 776 98	4	Schraube	Screw
07	133 035 12	1	Zuleitung kpl	Cable
08	365 538 40	1	Kabel	Cable
09	047 250 40	1	Stecker	Plug
10	145 763 40	1	Verschlusskappe	Tube pole cape
11	510 484 98	1	Blechschrabe	Sheet screw
12	604 896 40	1	Buchsenträger	Socket carrier
13	047 255 40	1	Tülle	Spout
14	592 943 40	6	Buchsen-Kontakt	Female contact
15	592 021 40	1	Stiftkontakt	Male contact
16	130 631 12	1	Leergehäuse	
17	021 124 12	1	Motor	Motor
18	021 122 12	1	Steuerplatine	Control plate
19	047 247 40	1	Steckdose mit Flansch	Flanged socket
20	047 249 40	1	Verschlußdeckel	Cover
21	320 973 99	2	Schraube	Screw
22	509 858 98	2	Mutter	Nut
23	346 507 99	2	Federring	Spring washer
29	021 123 12	1	Scheinwerfer und Vor- schaltgerät	Spotlight and pre-resistor
30	133 034 12	1	Hülse	Sleeve
31	308 907 99	1	Schraube	Screw
32	440 940 40	2	Scheibe	Washer

**Verstellscheinwerfer  
Spotlight, adjustable**

**168-6214**

Seite/Page 3 / 3