

**176-1030**

Seite/Page 1 / 4

01  
02

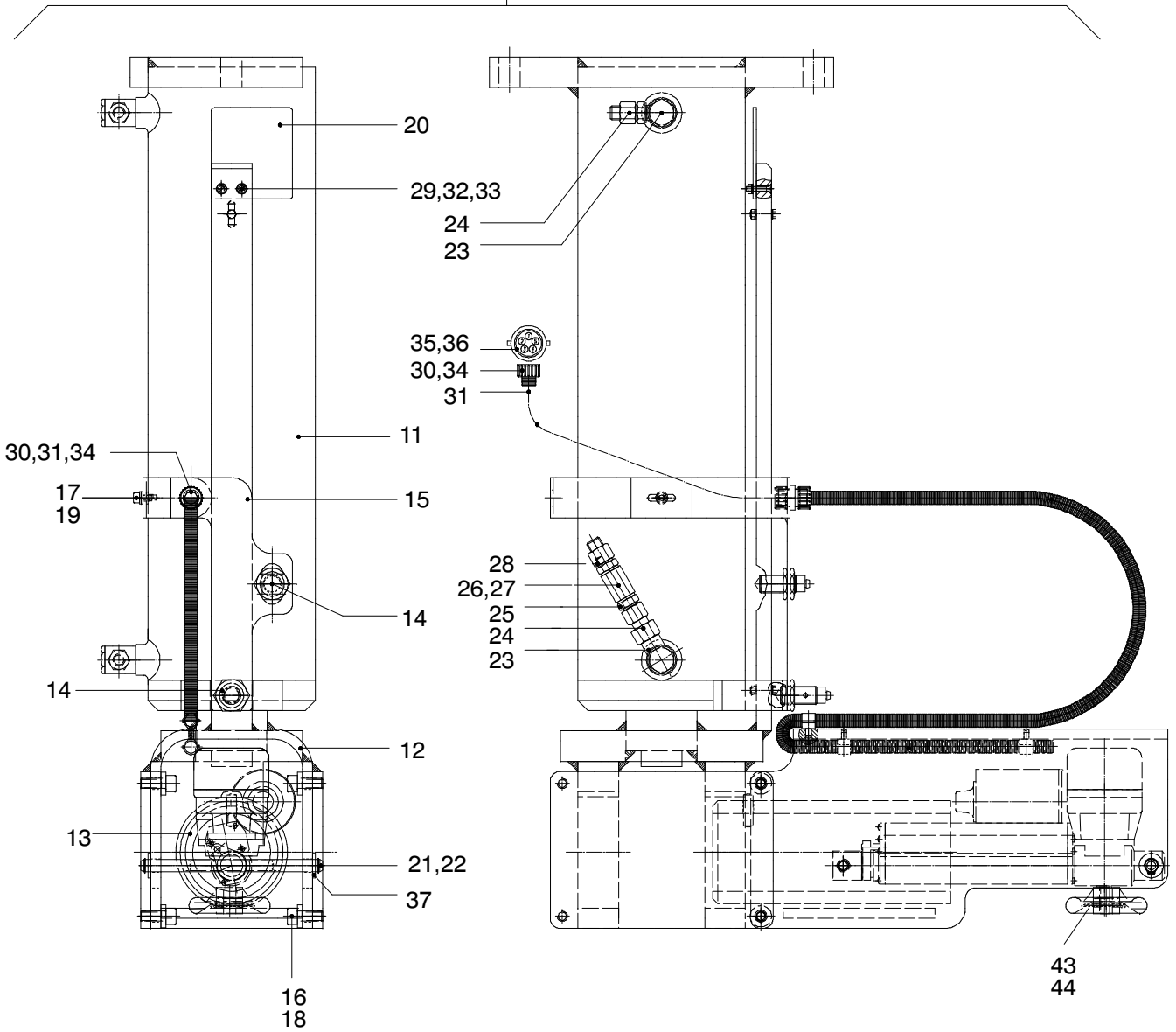

03

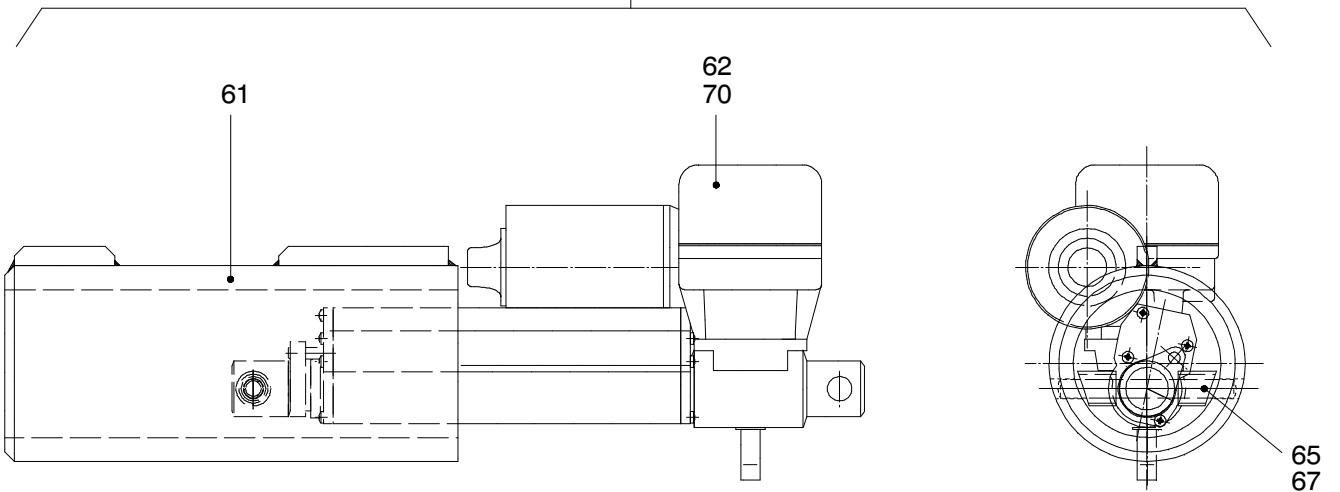

176-1030

Seite/Page 2 / 4

Bild-Nr Fig Fig Fig Fig Bild nr	ET-Nr Part-No No. de Piece No. de Pieza No. del Pezzo Detalj nr	Stückzahl Qty Qte Ctd Qta Antal		Gegenstand Description Designation Descripcion Designazione Benaemning
01	612 101 40	1	Verbolzungseinheit am Zylinder links, kpl. Bild-Nr. 11-47	Pin locking unit at l.h. cylinder assy. fig-nos. 11-47
02	612 102 40	1	Verbolzungseinheit am Zylinder rechts, kpl. Bild-Nr. 11-47	Pin locking unit at r.h. cylinder assy. fig-nos. 11-47
03	500 918 98	4	Schraube	Bolt
04	509 908 98	4	Mutter	Nut
05	340 513 99	8	Scheibe	Washer
11	611 795 40	1	Hubzylinder	Lift cylinder
-	979 581 73	-	Dichtsatz zu Bild-Nr. 11	Seal kit to fig-no. 11
12	611 801 40	1	Verbolzungseinheit, SK	Pin locking unit, weldment
13	611 799 40	1	Linearmotor, kpl. Bild-Nr. 61-67	Linear motor assy. fig-nos. 61-67
14	592 948 40	2	Ind. Näherungsschalter	Induction switch
-	979 370 73		Winkelstecker zu Bild-Nr. 14	Elbow plug to fig-no. 14
15	588 521 40	1	Halter	Retainer
16	509 794 98	4	Schraube	Bolt
17	509 776 98	1	Schraube	Screw
18	611 796 40	4	Ringblech	Ring sheet
19	509 768 98	1	Federring	Lock washer
20	612 099 40	1	Blech	Plate
21	611 803 40	1	Bolzen	Pin
22	342 512 99	2	Sicherungsring	Circlip
23	604 412 40	2	Stutzen	Socket
24	551 379 40	2	Stutzen	Socket
25	551 461 40	1	Stutzen	Socket
26	543 072 40	1	Düsenträger	Nozzle holder
27	255 391 40	1	Luftdüsen	Air nozzles
28	551 349 40	1	Stutzen	Socket
29	511 721 98	2	Senkschraube	Countersunk screw
30	592 290 40	3	Überwurfmutter	Union nut
31	*	-	Wellrohr	Corrugated pipe
32	340 461 99	2	Scheibe	Washer
33	510 875 98	2	Mutter	Nut
34	592 286 40	3	Dichtring	Seal ring
35	592 683 40	1	Stiftgehäuse	Pin shell
36	551 327 40	5	Stiftkontakt	Male contact
37	510 494 98	2	Scheibe	Washer
39	635 182 40	1	Kegel mit Bajonett	Cone with bayonet
40	511 437 98	4	Senkschraube	Countersunk screw

**Verbolzungseinheit  
Pin Locking Unit**

**176-1030**

Seite/Page 3 / 4

<b>Bild-Nr</b> Fig Fig Fig Fig Bild nr	<b>ET-Nr</b> Part-No No. de Piece No. de Pieza No. del Pezzo Detalj nr	<b>Stückzahl</b> Qty Qte Ctd Qta Antal		<b>Gegenstand</b> Description Designation Descripcion Designazione Benaemning
41	509 858 98	4	Mutter	Nut
42	510 688 98	4	Scheibe	Washer
43	604 201 40	1	Handrad	Hand wheel
44	501 999 98	1	Spannstift	Dowel pin
45	589 483 40	1	Bodenblech	Bottom plate
46	509 912 98	6	Schraube	Screw
47	509 766 98	6	Federring	Lock washer
51	611 798 40	1	Verbolzungseinheit, SK	Pin locking unit, weldment
52	634 338 40	3	Halteclip	Clip
61	588 298 40	1	Bolzen mit Führung	Pin with guide
62	-	1	Linear-Motor s. EL-Blatt 993-0400	Linear motor see page 993-0400
65	511 868 98	1	Zylinderkerbstift	Straight grooved pin
67	588 271 40	2	Rohr	Pipe assy.
70	978 253 73	4	Microschalter	Micro switch
			* Meterware, bei Bestellung Länge angeben	* Bulk ware, state length required
*	592 294 40	-	Wellrohr	Corrugated pipe

**Verbolzungseinheit  
Pin Locking Unit**

**176-1030**

Seite/Page 4 / 4