

00

Oberwagen Superstructure

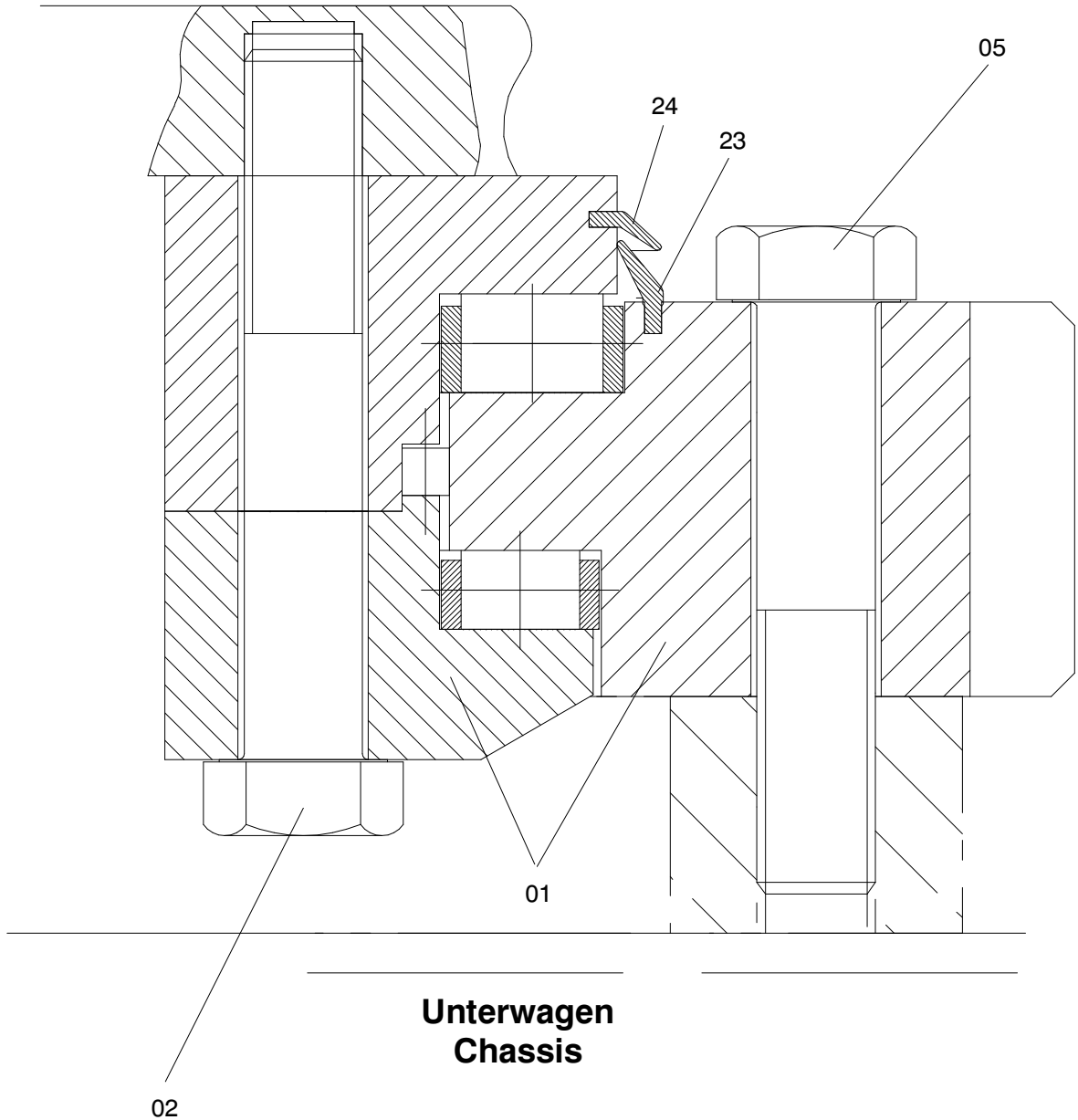

176-1100a

Seite/Page 1 / 3

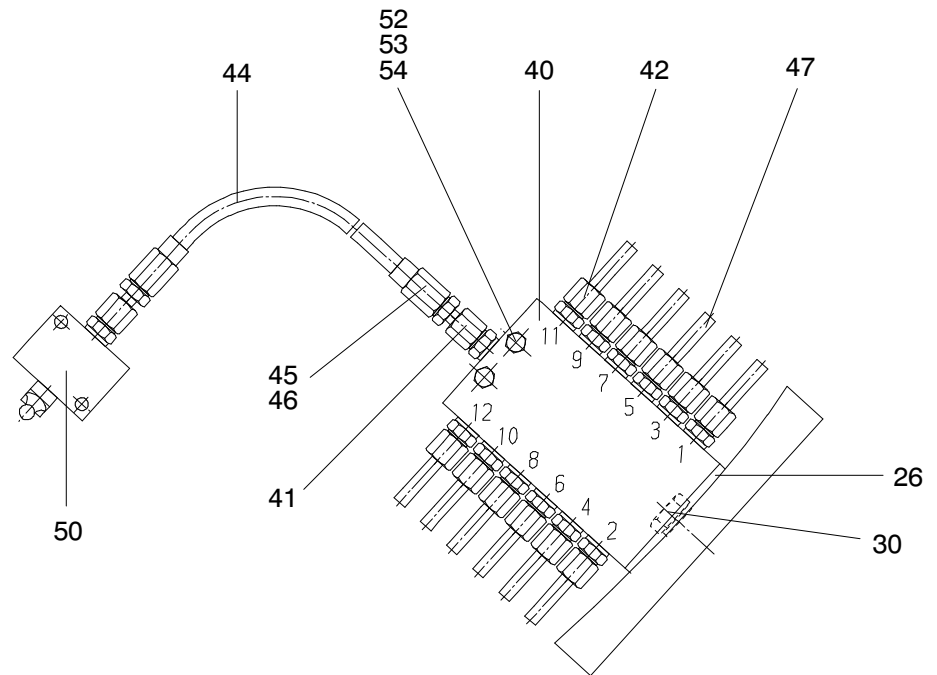
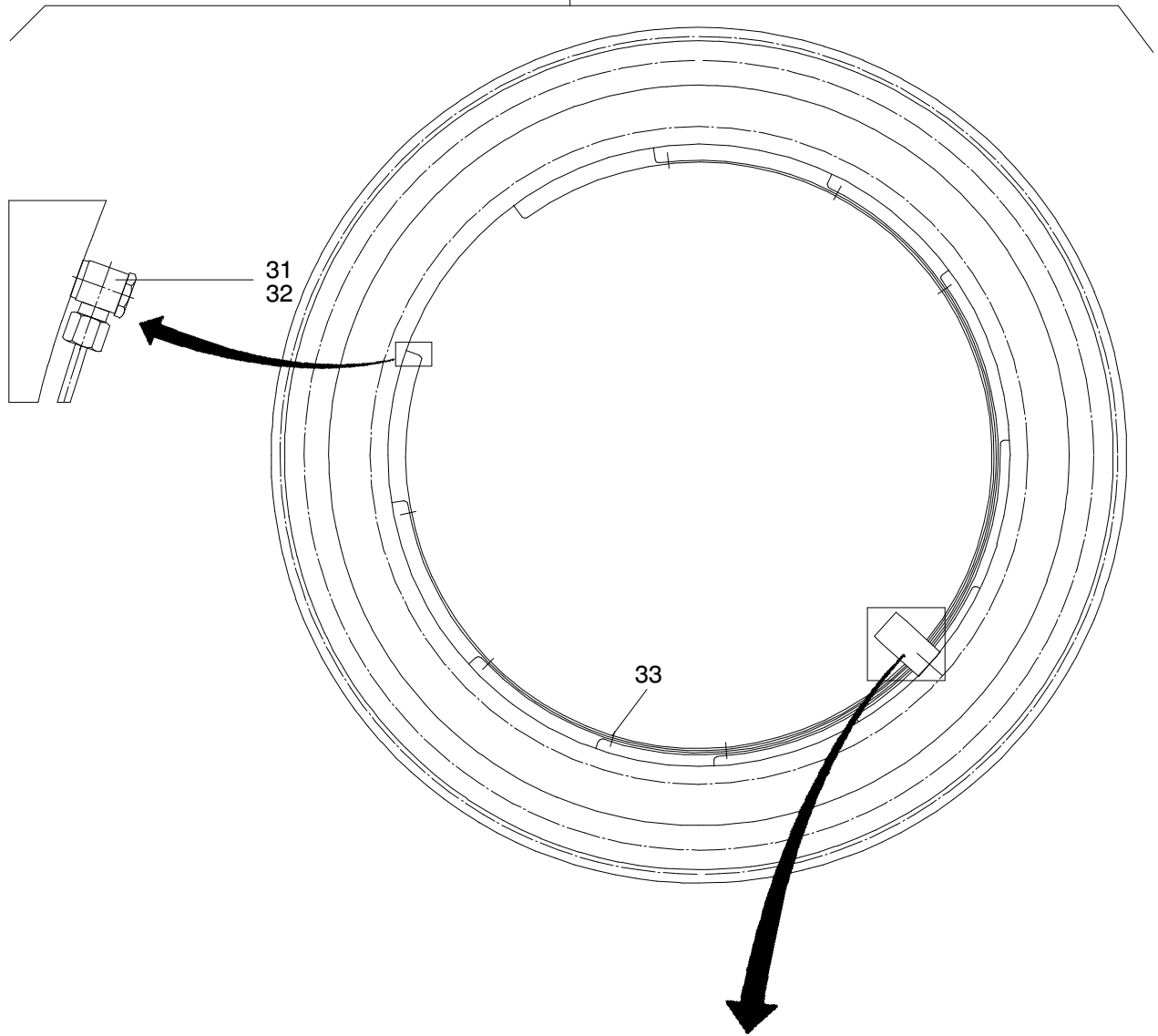

176-1100a

Bild-Nr Fig Fig Fig Fig Bild nr	ET-Nr Part-No No. de Piece No. de Pieza No. del Pezzo Detalj nr	Stückzahl Qty Qte Ctd Qta Antal		Gegenstand Description Designation Descripcion Designazione Benaemning
00	612 901 40	1	Rollendrehverbindung, kpl. ohne Bild-Nr. 05	Slew ring assy. w/o fig-no. 05
01	612 991 40	1	Rollendrehverbindung	Slew ring
02	125 044 99	62	Schraube	Bolt
-	509 384 98	2	Zylinderstift	Parallel pin
05	308 815 12	76	Schraube	Bolt
22	502 497 98	3	Fett, 1 kg.	Grease
23	487 138 40	1	Lippendichtung	Lip type seal
24	487 163 40	1	Lippendichtung	Lip type seal
25	626 997 40	1	Zentralschmierung, kpl.	Central lubrication assy.
26	593 472 40	1	Befestigungswinkel	Fixing angle
30	500 813 98	1	Schraube	Bolt
-	056 292 40	12	Kabelbinder	Cable strap
40	324 014 40	1	Verteiler 12	Distributor
41	765 410 73	1	Verschraubung	Union
42	765 411 73	12	Verschraubung	Union
44	698 212 73	1	Schlauch 2 m lg.	Hose assy.
45	515 027 40	2	Schlauchstutzen	Hose connection
46	515 028 40	2	Schraubhülse	Collet
47	421 460 12	1	Kunststoffrohr ø 6 Länge angeben	Plastic pipe State length required
50	978 481 73	1	Nippelblock	Fitting block
51	978 561 73	12	Verschraubung	Union
52	319 135 99	2	Schraube	Bolt
53	507 025 98	2	Mutter	Nut
54	346 499 99	2	Federring	Lock washer

**Rollendrehverbindung
Slew ring**

176-1100a

Seite/Page 3 / 3