

Ansicht A

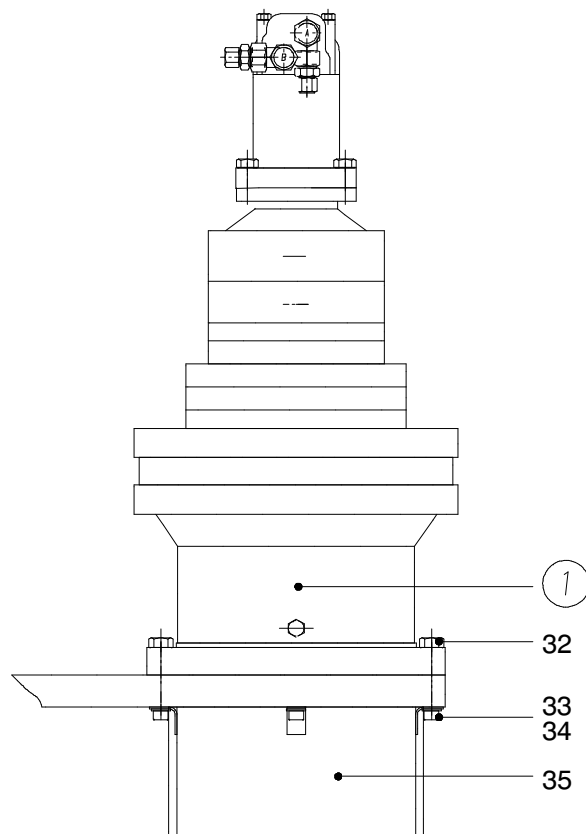
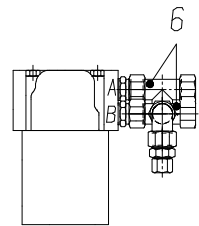

Bild-Nr Fig Fig Fig Fig Bild nr	ET-Nr Part-No No. de Piece No. de Pieza No. del Pezzo Detalj nr	Stückzahl Qty Qte Ctd Qta Antal		Gegenstand Description Designation Descripcion Designazione Benaemning
01	-	1	Drehwerksgetriebe s. EL-Blatt 90-3328	Slew gearbox see page 90-3328
02	-	1	Hydr.-Motor s. EL-Blatt 90-3329	Hydr. motor see page 90-3329
03	510 868 98	2	Schraube	Bolt
06	551 454 40	2	Stutzen	Socket
07	551 456 40	2	Stutzen	Socket
15	511 094 98	2	Scheibe	Washer
16	621 793 40	1	Stutzen	Socket
17	551 908 40	1	Schlauchleitung	Hose assy.
18	634 779 40	1	Verschlußkegel	Locking cone
19	509 809 98	1	Überwurfmutter	Union nut
20	551 447 40	1	Stutzen	Socket
21	551 615 40	1	Stutzen	Socket
22	551 985 40	1	Kupplung	Coupling
32	511 093 98	15	Schraube	Bolt
33	509 793 98	3	Schraube	Bolt
34	510 314 98	3	Scheibe	Washer
35	612 957 40	1	Ritzelschutz	Pinion cover

**Drehwerk
Slew gear**

176-1500

Seite/Page 2 / 2