

179-2100

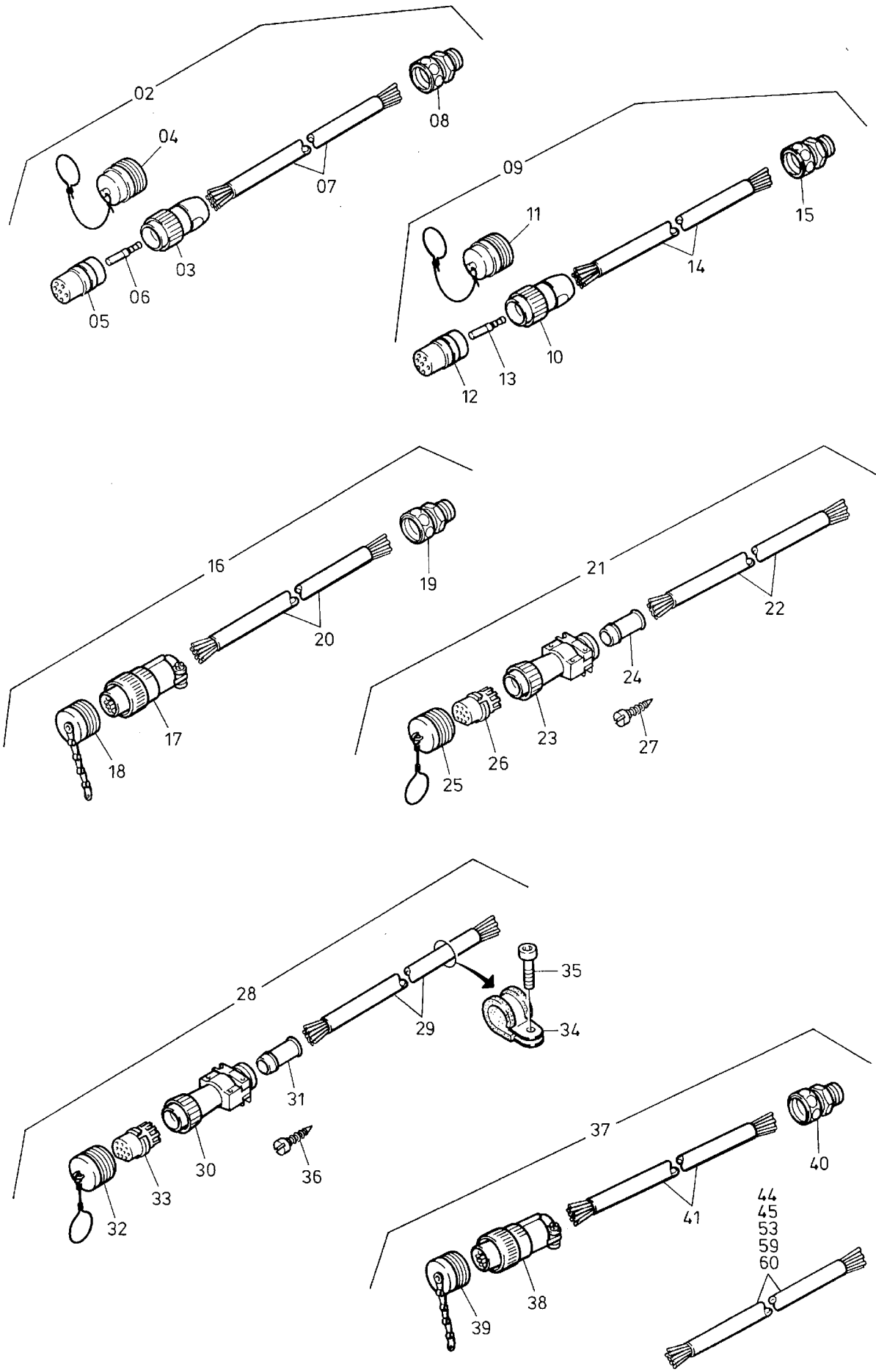

179-2100

Bild-Nr Fig Fig Fig Fig Bild nr	ET-Nr Part-No No. de Piece No. de Pieza No. del Pezzo Detalj nr	Stückzahl Qty Qte Ctd Qta Antal		Gegenstand Description Designation Descripcion Designazione Benaemning
01	-		Hängetaster siehe EL-Blatt 179-2103	Hanging key button see page 179-2103
02	455 574 40	1	Zuleitung-Versorgung OW-HA	Feeder line supply superstructure - main boom
-	570 507 40	1	Schlauchhalterung kpl .zu Bild 02,09u.16	Hose clamp to fig. 02,09 16
03	490 964 40	1	Stecker	Plug
04	490 965 40	1	Verschlußkappe	Tube pole cap
05	490 966 40	1	Buchsenträger 12polig	Sleeve carrier
06	490 967 40	13	Buchsenkontakt	Female contact
07	348 766 40	1	Kabel-8m lang	Cable
08	269 826 40	1	Kabelverschraubung	Cable union
09	527 536 40	1	Zuleitung-Steuerung OW-HA best. aus Bild-Nr. 10-15	Feeder line control superstructure-main boom consist of fig-nos-10-15
10	490 964 40	1	Stecker	Plug
11	490 965 40	1	Verschlußkappe	Tube pole cap
12	490 975 40	1	Buchsenträger 64-polig	Sleeve carrier
13	490 976 40	65	Buchsenkontakt	Female contact
14	369 186 40	1	Kabel 8m lang	Cable
15	269 826 40	1	Kabelverschraubung	Cable union
16	552 163 40	1	Zuleitung LMB im OW-HA best. aus Bild-Nr. 17-20	Feeder line LML in superstructure-main boom consist. of fig-nos: 17-20
17	551 775 40	1	Stecker 20polig mit Buchsenkontakt	Plug, 20-pole, female
18	551 776 40	1	Staubkappe	Dust cap
19	300 988 40	1	Kabelverschraubung	Cable union
20	551 971 40	1	Kabel 12m lang	Cable
21	527 537 40	1	Kabel mit Stecker best. aus Bild-Nr. 22-27	Cable with plug consist of fig-nos: 22-27
22	369 200 40	1	Kabel 10m lang	Cable
23	385 112 40	1	Stecker m. Zugentlastung	Cable with strain relief
24	371 242 40	1	Tülle	Spout
25	368 636 40	1	Verschlußkappe	Tube pole cap
26	405 432 40	1	Buchsenträger	Sleeve carrier
27	350 340 99	1	Blechschrabe	Tapped screw
28	527 538 40	2	Kabel mit Stecker best. aus Bild-Nr. 29-36	Cable with plug consist. of fig-nos: 29-36
29	369 538 40	1	Kabel - 10m lang -	Cable
30	047 250 40	1	Stecker 7polig	Plug
31	047 255 40	1	Tülle	Spout
32	145 463 40	1	Verschlußkappe	Tube pole cap
Elektrik Oberwagen			179-2100	
Electric Superstructure			Seite/Page 3/5	

Bild-Nr Fig Fig Fig Fig Bild nr	ET-Nr Part-No No. de Piece No. de Pieza No. del Pezzo Detalj nr	Stückzahl Qty Qte Ctd Qta Antal		Gegenstand Description Designation Description Designazione Benaemning
33	047 251 40	1	Kontaktelement	Contact element
34	006 339 98	1	Schelle	Clamp
35	321 016 99	1	Zyl.-Schraube	Bolt
36	510 484 99	1	Blechschraube	Tapped screw
37	552 164 40	1	Zuleitung UW best. aus Bild-Nr. 38-41	Feeder line chassis consist. of fig-nos: 38-41
38	551 778 40	1	Steckdose 20polig	Plug
39	551 779 40	1	Staubkappe	Dust cap
40	300 988 40	1	Kabelverschraubung	Cable union
41	551 971 40	1	Kabel - 5m lang -	Cable
42	*		Kabel 4x0,75	Cable
43	-	2	Druckaufnehmer siehe EL-Blatt 90-6364	Pressure contact see page 90-6364
44	*		Kabel 3x1	Cable
45	*		Kabel 11x4	Cable
46	295 201 40	2	Batterie	Battery
47	420 246 99	2	Schraubklemme	Clamp
48	420 247 99	2	Schraubklemme	Clamp
49	160 999 40	1	Sicherungsdose	Fuse box
50	321 009 99	2	Zyl.-Schraube	Bolt
51	323 109 99	2	Skt.-Mutter	Nut
52	346 509 99	2	Federring	Lock washer
53	*		Kabel	Cable
54	600 221 99	2	Kabelschuh 10-120	Cable shoe
55	270 869 40	2	Motor-Masseband	Grounding cable
56	330 248 40	2	Anlasser-Schutzkappe	Protecting cap
57	551 552 40	4	Verteiler - 8fach -	Distributor
58	515 421 40	9	Stecker mit Kabel 10m lang	Plug with cable
59	*		Kabel 8x1	Cable
60	*		Kabel 30x0,5	Cable
61	058 443 40	1	Horn	Horn
62	414 522 40	4	Reduzierung	Reduction
63	323 693 40	4	Kabelverschraubung	Cable union
-	461 265 40	2	Rundumleuchte	Rotaf flare light
-	507 372 99	2	Glühlampe	Bulb
			Japanausführung	Japan design
-	058 343 40	2	Positionsleuchte,rot hinten	Position light r.h.
-	601 344 40	1	Halter,links	Retainer l.h.
-	601 859 40	1	Halter,rechts	Retainer r.h.
-	307 425 99	4	Schraube zu Halter	Srew
-	343 108 99	4	Federring	Lock washer
-	416 060 40	1	Kennleuchte,hinten	Marking light, rear

Bild-Nr Fig Fig Fig Fig Bild nr	ET-Nr Part-No No. de Piece No. de Pieza No. del Pezzo Detalj nr	Stückzahl Qty Qte Ctd Qta Antal		Gegenstand Description Designation Descripcion Designazione Benaemning
-	440 305 99	1	Stecker	Plug
			* Meterware, bei Bestellung Länge angeben	* Bulk ware, state length required
*	270 667 40		Kabel 30x0,5	Cable
*	551 970 40		Kabel 4x0,75	Cable
*	369 198 40		Kabel 3x1	Cable
*	369 199 40		Kabel 8x1	Cable
*	551 978 40		Kabel 11x4	Cable
*	269 625 40		Massekabel	Ground cable
Elektrik Oberwagen Electric Superstructure			179-2100	
			Seite/Page 5/5	