

179-2202c

Seite/Page 1 / 5

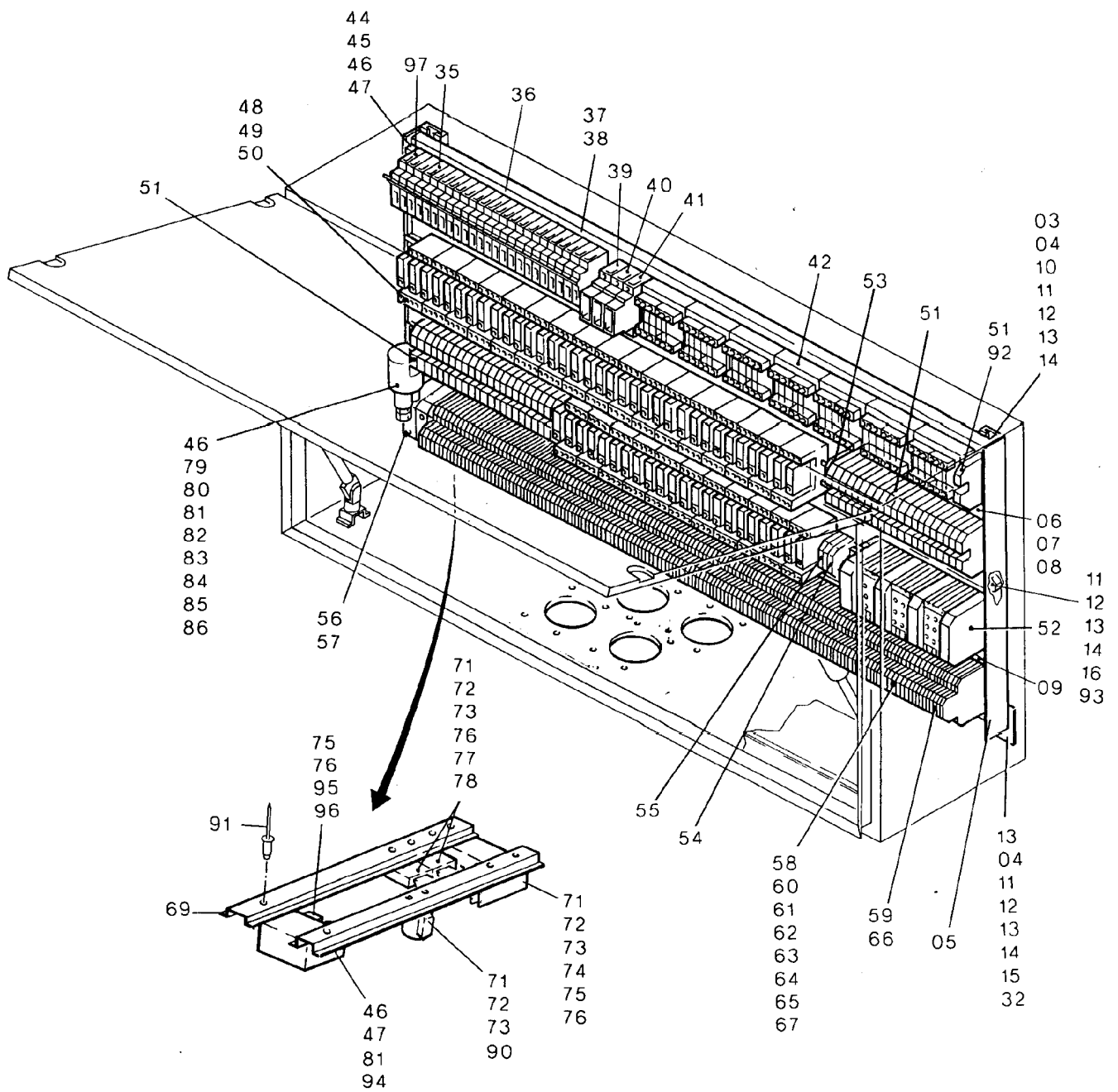

179-2202c

Bild-Nr Fig Fig Fig Fig Bild nr	ET-Nr Part-No No. de Piece No. de Pieza No. del Pezzo Detalj nr	Stückzahl Qty Qte Ctd Qta Antal		Gegenstand Description Designation Descripcion Designazione Benaemning
00	662 809 40	1	Schaltkasten, kpl.	Switch box assy.
01	551 517 40	1	Schaltschrank	Switch cabinet
02	504 043 98	8	Schraube	Bolt
03	504 212 98	16	Mutter	Nut
04	440 940 40	14	Unterlegscheibe	Washer
05	551 543 40	2	Tragschiene	Assembly rail
06	551 542 40	4	Montagegesteg	Mounting stage
07	654 332 40	5	Kantenschutzprofil	Cleat
08	323 234 40	-	Deckel	Cover
09	323 648 40	-	Verdrahtungskamm	Wiring terminal
10	307 688 99	2	Schraube	Bolt
11	340 464 99	40	Scheibe	Washer
12	332 197 99	32	Mutter	Nut
13	343 094 99	12	Federring	Lock washer
14	332 111 99	12	Mutter	Nut
15	003 121 98	4	Sicherung	Fuse
16	307 431 99	8	Schraube	Bolt
17	137 273 40	3	Entlüftungsstutzen	Bleeder nozzle
18	600 806 99	3	Mutter	Nut
19	634 263 40	-	Verdrahtungskanal	Wiring channel
22	576 488 40	2	Gasfeder	Gas operated positioner
23	324 444 99	2	Gewindestift	Threaded pin
24	350 750 99	4	Gabelkopf	Fork end
25	002 825 98	4	Bolzen	Pin
26	323 229 40	1	Tragschiene	Assembly rail
27	634 079 40	4	Anschlußarmatur	Fitting
28	307 646 99	16	Schraube	Bolt
29	320 068 99	16	Mutter	Nut
30	340 463 99	16	Scheibe	Washer
31	634 077 40	-	Kabelschutzwelrohr	Cable protection pipe
32	308 093 99	2	Schraube	Bolt
35	323 770 40	1	Flachautomat	Trip fuse
36	323 769 40	15	Flachautomat	Trip fuse
37	343 843 40	6	Flachautomat	Trip fuse
38	621 700 40	1	Kammschiene	Com rail
39	323 407 40	1	Zeitrelais	Time lag relay
40	551 511 40	1	Zeitrelais	Time lag relay
41	440 600 40	1	Zeitrelais	Time lag relay
42	621 952 40	7	Diodenmodul	Diode module
44	180 221 40	1	Schaltrelais	Switching relay

Schaltkasten X2
Switch Box

179-2202c

Seite/Page 3 / 5

Bild-Nr Fig Fig Fig Fig Bild nr	ET-Nr Part-No No. de Piece No. de Pieza No. del Pezzo Detalj nr	Stückzahl Qty Qte Ctd Qta Antal		Gegenstand Description Designation Descripcion Designazione Benaeming
45	324 068 40	1	Tragsockel	Supporting trestle
46	340 461 99	5	Scheibe	Washer
47	320 816 99	3	Zylinderschraube	Screw
48	346 528 40	28	Relaisbaustein	Relay modul
49	346 529 40	56	Industrirelais	Relay assy.
50	635 575 40	56	Haltebügel	Retainer
51	551 005 40	54	Relaiskoppler	Coupling relais
52	634 859 40	3	Verstärkermodul	Amplifier module
53	635 139 40	4	Abgleichklemme	Equalizer terminal
54	635 109 40	1	Abgleichklemme	Equalizer terminal
55	324 058 40	2	Abgleichklemme	Equalizer terminal
56	576 005 40	3	Klemme	Clamp
57	576 006 40	1	Querverbinder	Cross connection
58	551 695 40	59	Klemme	Clamp
59	551 694 40	3	Klemme	Clamp
60	551 696 40	8	Querverbinder	Cross connection
61	551 698 40	1	Bezeichnungskarte 1-100	Marker 1-100
62	551 699 40	1	Bezeichnungskarte 101-200	Marker 101-200
63	551 700 40	1	Bezeichnungskarte 201-300	Marker 201-300
64	551 701 40	1	Bezeichnungskarte 301-400	Marker 301-400
65	551 702 40	2	Bezeichnungskarte "Erde"	Marker "ground"
66	551 703 40	1	Bezeichnungskarte "Minus"	Marker "minus"
67	551 697 40	1	Querbrückungskamm	Cross bridging comb
69	874 533 40	-	Halteschiene	Holding rail
71	340 459 99	8	Scheibe	Washer
72	334 649 99	8	Mutter	Nut
73	320 815 99	8	Zylinderschraube	Screw
74	551 334 40	1	Spannungswandler	Voltage converter
75	255 688 40	2	Steckergehäuse	Socket
76	057 251 40	24	Steckhülse	Sleeve
77	461 251 40	4	Impulsgeber	Sender
78	057 331 40	2	Steckhülsegehäuse	Female housing
79	358 293 40	1	Leistungsrelais	Relay
80	307 703 99	2	Schraube	Bolt
81	332 101 99	2	Mutter	Nut
82	592 434 40	2	Kabelschuh	Cable lug
83	*	-	Kabel, schwarz	Cable, black
84	490 580 40	2	Kabelschuh	Cable lug
85	*	-	Kabel, rot	Cable, red
86	500 466 98	2	Sicherung	Fuse
89	662 858 40	1	Klebestreifen	Tape

Schaltkasten X2
Switch Box

179-2202c

Seite/Page 4 / 5

Bild-Nr Fig Fig Fig Fig Bild nr	ET-Nr Part-No No. de Piece No. de Pieza No. del Pezzo Detalj nr	Stückzahl Qty Qte Ctd Qta Antal		Gegenstand Description Designation Descripcion Designazione Benaemning
90	057 278 40	1	Steckdose	Socket
91	288 769 40	8	Blindniet	Blind rivet
92	370 049 40	1	Kondensator	Condensator
93	308 569 99	6	Schraube	Bolt
94	346 509 99	2	Federring	Lock washer
95	576 356 40	4	Steckhülsenkontakt	Sleeve contact
96	047 014 40	1	Steckhülsegehäuse	Female housing
97	323 767 40	1	Flachautomat	Trip fuse
			* Meterware, bei Bestellung Länge angeben	* Bulk ware, state length required
*	471 667 99	-	Kabel, schwarz	Cable, black
*	471 685 99	-	Kabel, rot	Cable, red

Schaltkasten X2
Switch Box

179-2202c

Seite/Page 5 / 5