

184-1903a

Seite/Page 1 / 3

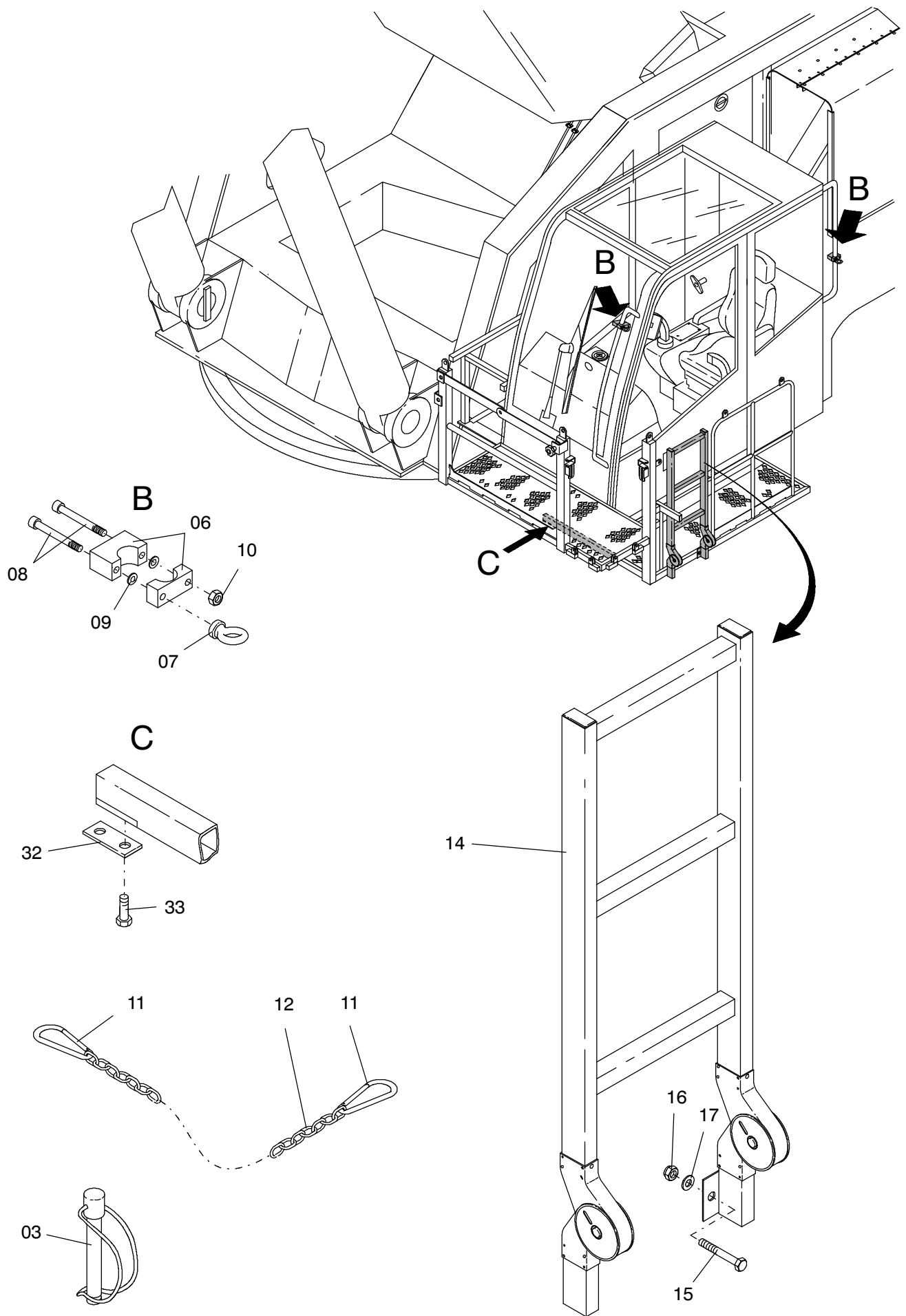

184-1903a

Seite/Page 2 / 3

Bild-Nr Fig Fig Fig Fig Bild nr	ET-Nr Part-No No. de Piece No. de Pieza No. del Pezzo Detalj nr	Stückzahl Qty Qte Ctd Qta Antal		Gegenstand Description Designation Descripcion Designazione Benaemning
02	114 593 12	1	Leiter	Ladder
03	592 916 40	2	Klappstecker	Fore lock
04	307 427 99	4	Schraube	Bolt
05	350 763 99	8	Scheibe	Washer
06	533 991 99	4	Klemmhälftenpaar	Pair of half clamps
07	117 635 12	2	Ringmutter	Ring nut
08	319 133 99	4	Schraube	Bolt
09	340 405 99	2	Scheibe	Washer
10	509 861 98	2	Mutter	Nut
11	501 707 98	8	Karabinerhaken	Trigger snap
12	509 649 98	1	Kette Meterware, bei Bestellung Länge angeben	Chain Bulk ware, state length required
13	001 003 12	2	Klappstecker	Fore lock
14	144 969 12	1	Leiter	Ladder
15	125 102 99	2	Schraube	Bolt
16	509 876 98	2	Mutter	Nut
17	340 608 99	4	Scheibe	Washer
21	144 270 12	1	Podest	Platform
22	119 108 12	1	Sicherheitsrost	Saftey grating
23	144 268 12	1	Sicherheitsrost	Saftey grating
24	119 109 12	2	Winkel	Angle
25	307 750 99	4	Schraube	Bolt
27	307 729 99	16	Schraube	Bolt
28	332 110 99	16	Mutter	Nut
30	509 862 98	4	Mutter	Nut
31	307 425 99	6	Schraube	Bolt
32	119 114 12	4	Blech	Sheet
33	307 777 99	8	Schraube	Bolt
34	144 852 12	2	Halter	Retainer
35	334 690 99	2	Mutter	Nut
36	144 269 12	1	Blech	Sheet
37	145 015 12	1	Strebe	Brace
38	001 800 12	1	Sterngriff	Star grip
39	145 016 12	1	Strebe	Brace

**Anbau Podest - Kabine
Mounting Platform Cabin**

184-1903a

Seite/Page 3 / 3