

**187-6035b**

Seite/Page 1 / 7

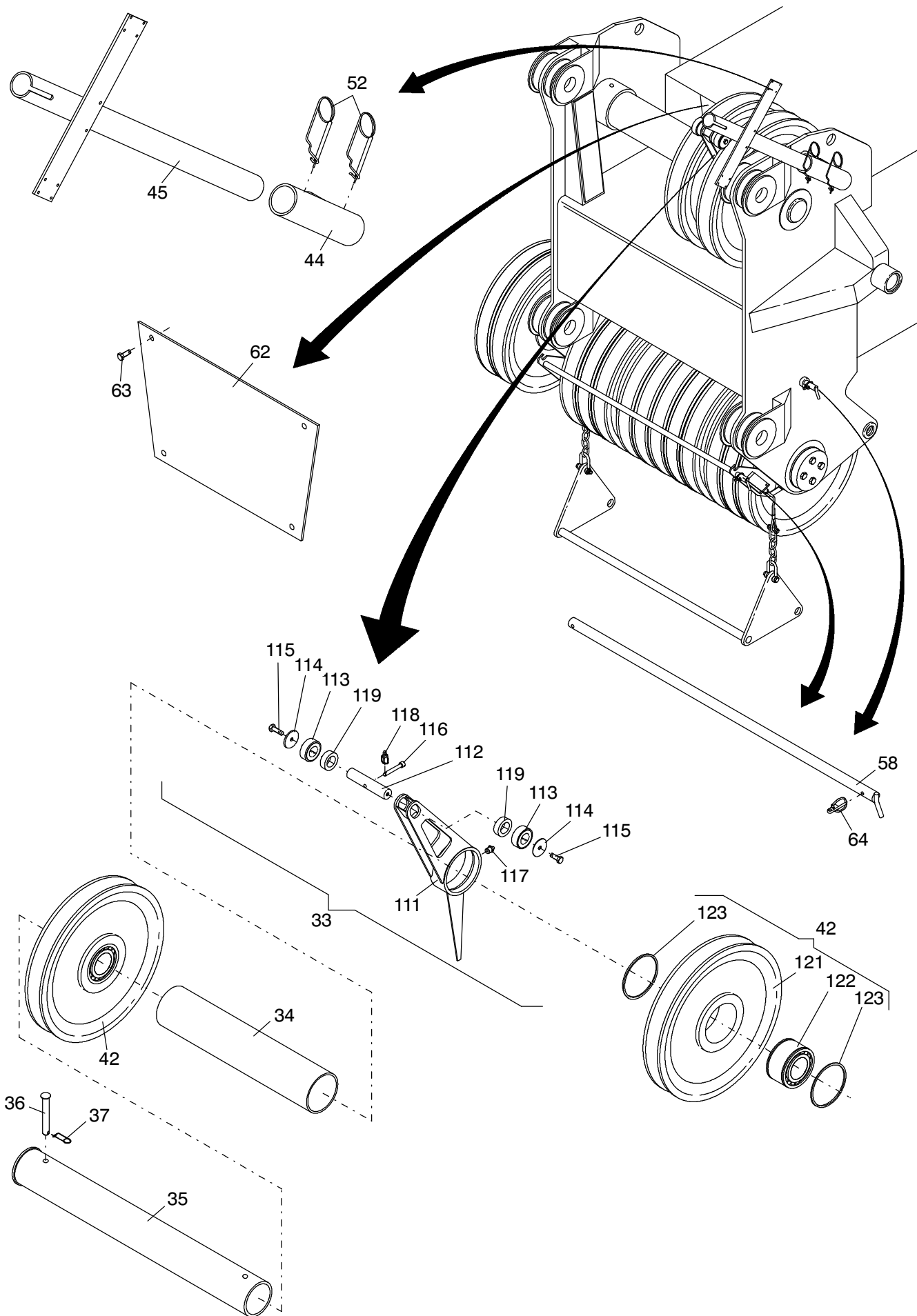

**187-6035b**

Seite/Page 2 / 7

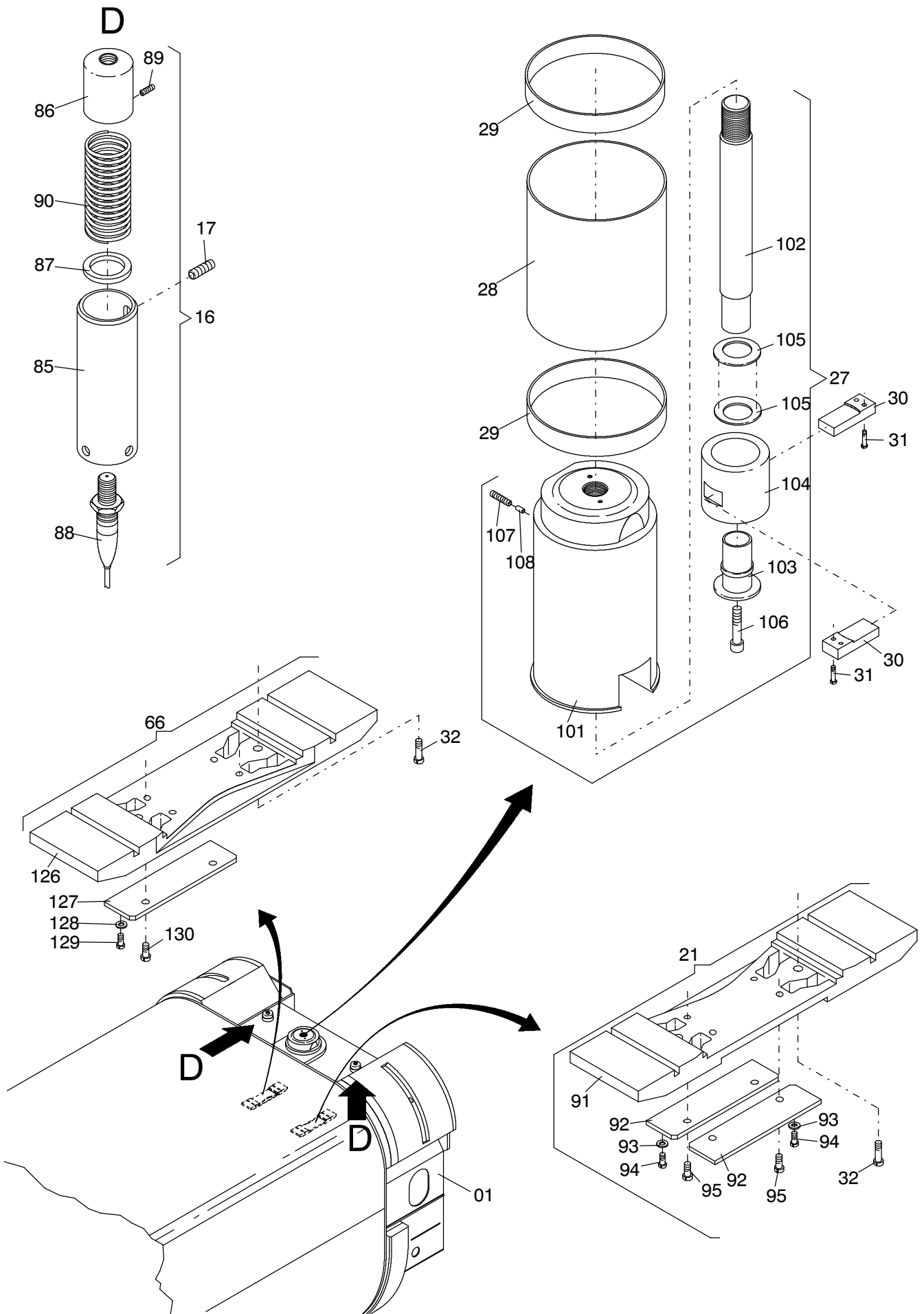

**187-6035b**

Seite/Page 3 / 7

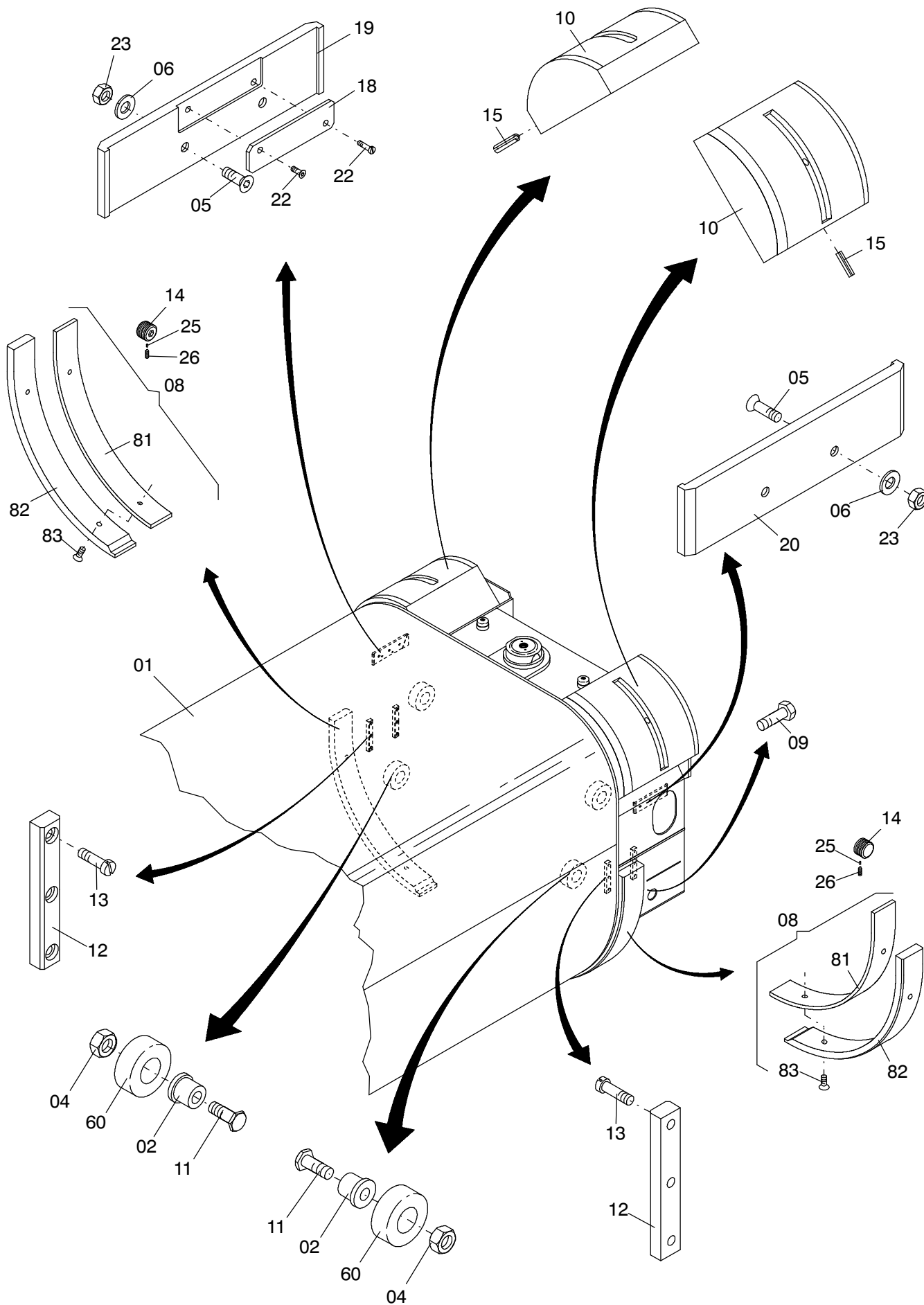

**187-6035b**

Bild-Nr Fig Fig Fig Fig Bild nr	ET-Nr Part-No No. de Piece No. de Pieza No. del Pezzo Detalj nr	Stückzahl Qty Qte Ctd Qta Antal		Gegenstand Description Designation Descripción Designazione Benaemning
-	885 840 40	1	4. Innenkasten	4th Inner case
01	885 841 40	1	4. Innenkasten, SK	4th Inner case, weldment
02	885 696 40	8	Buchse	Bushing
04	332 361 99	8	Mutter	Nut
05	318 397 99	4	Schraube	Bolt
06	340 508 99	4	Scheibe	Washer
07	000 204 12	8	Stützrolle	Roller
08	113 793 12	2	Gleitstück einschl. Bild-Nr. 81-83	Slider incl. fig-no. 81-83
09	509 284 98	6	Schraube	Bolt
10	885 449 40	2	Gleitbacken	Lining
11	885 697 40	8	Schraube	Bolt
12	110 175 12	4	Scheuerleiste	Rub rail
13	320 326 99	12	Schraube	Screw
14	117 336 12	12	Schraubstopfen	Screw plug
15	345 062 99	2	Spannstift	Dowel pin
16	111 678 12	2	Telepositionierung einschl. Bild-Nr. 85-90	Indicator incl. fig-no 85-90
17	325 261 99	2	Gewindestift	Threaded pin
18	161 054 12	1	Schaltleiste	Hinge rail
19	161 053 12	1	Führungsleiste	Guide bead
20	112 994 12	1	Führungsleiste	Guide bead
21	116 524 12	1	Stromschiene einschl. Bild-Nr.91-95	Current rail incl. fig-no. 91-95
22	320 471 99	1	Schraube	Screw
23	125 021 99	4	Mutter	Nut
25	110 371 12	12	Stift	Pin
26	324 497 99	12	Gewindestift	Threaded pin
27	111 986 12	1	Verriegelungsbolzen einschl. Bild-Nr. 101-108	Lock pin incl. fig-no. 101-108
28	111 520 12	1	Rohr	Pipe
29	007 587 98	2	Innenring	Internal ring
30	111 011 12	2	Niederhalter	Hold down
31	319 269 99	4	Schraube	Bolt
32	319 245 99	4	Schraube	Screw
33	111 504 12	1	Seilschutz einschl. Bild-Nr. 111-119	Sheave protection incl. 111-119
34	111 521 12	1	Rohr	Pipe
35	148 399 12	1	Achse	Axle
36	111 514 12	2	Bolzen	Pin
37	007 266 98	2	Sicherungsfeder	Locking spring

**4. Innenkasten mit Rollenkopf  
4th. Inner Case with Sheave Head**

**187-6035b**

Seite/Page 5 / 7

Bild-Nr Fig Fig Fig Fig Bild nr	ET-Nr Part-No No. de Piece No. de Pieza No. del Pezzo Detalj nr	Stückzahl Qty Qte Ctd Qta Antal		Gegenstand Description Designation Descripcion Designazione Benaemning
38	111 511 12	1	Achse	Axle
39	111 522 12	1	Rohr	Pipe
40	111 513 12	2	Scheibe	Washer
41	307 612 99	8	Schraube	Bolt
42	631 809 40	15	Seilrolle einschl. Bild-Nr. 121-123	Sheave incl. fig-no 121-123
43	111 509 12	1	Seilbügel	Rope shackle
44	664 267 40	1	Adapter	Adapter
45	884 790 40	1	Halter für Windmesser	Retainer for Anemometer
46	300 056 99	2	Schäkel	Clevis
47	307 757 99	2	Schraube	Screw
48	334 626 99	4	Mutter	Nut
49	506 807 98	2	Schäkel	Clevis
50	*	-	Kette	Chain
51	341 271 99	2	Karabinerhaken	Trigger snap
52	665 882 40	2	Bolzensicherung	Pin lock
53	111 524 12	1	Rohr	Pipe
54	621 275 40	1	Hubendschalter	Hoist limit switch
55	319 246 99	4	Schraube	Screw
56	111 523 12	2	Rohr	Pipe
57	621 443 40	1	Hubendschalter Überbrückungsfahne	Marker for hoist limit switch
58	111 515 12	2	Steckbolzen	Socket pin
59	334 627 99	2	Mutter	Nut
60	307 781 99	2	Schraube	Bolt
61	511 618 98	2	Klappstecker	Fore lock
62	114 927 12	1	Abdeckblech	Cover plate
63	315 528 40	4	Schraube	Screw
64	461 665 40	2	Klappstecker	Fore lock
65	114 515 12	1	Rohr	Pipe
66	116 523 12	1	Stromschiene einschl. Bild-Nr. 126-130	Current rail incl. fig-no 126-130
81	110 644 12	1	Blech	Sheet
82	110 643 12	1	Gleitstück	Slider
83	320 446 99	2	Schraube	Bolt
85	111 677 12	1	Rohr	Pipe
86	638 453 40	1	Stößel	Tappet
87	340 619 99	1	Scheibe	Washer
88	515 888 40	1	Nährungsschalter	Switch
89	324 532 99	1	Gewindestift	Threaded pin
90	506 209 98	1	Druckfeder	Compression spring
91	115 774 12	1	Führung	Guide

**4. Innenkasten mit Rollenkopf  
4th. Inner Case with Sheave Head**

**187-6035b**

Seite/Page 6 / 7

Bild-Nr Fig Fig Fig Fig Bild nr	ET-Nr Part-No No. de Piece No. de Pieza No. del Pezzo Detalj nr	Stückzahl Qty Qte Ctd Qta Antal		Gegenstand Description Designation Descripcion Designazione Benaemning
92	116 259 12	2	Stromschiene	Current rail
93	340 462 99	4	Scheibe	Washer
94	320 941 99	2	Schraube	Screw
95	320 942 99	4	Schraube	Screw
101	110 642 12	1	Verriegelungsbolzen	Lock pin
102	111 979 12	1	Bolzen	Pin
103	111 977 12	1	Pilz	Mushroom shaped
104	111 978 12	1	Führungsrohr	Guide tube
105	151 088 99	37	Tellerfeder	Cup spring
106	319 297 99	1	Schraube	Bolt
107	324 453 99	1	Gewindestift	Threaded pin
108	367 204 40	2	Bolzen	Pin
111	111 505 12	1	Seilschutz	Rope protection
112	638 668 40	1	Bolzen	Pin
113	001 941 98	2	Stützrolle	Roller
114	638 839 40	2	Ring	Ring
115	307 464 99	2	Schraube	Bolt
116	601 426 40	1	Bolzen	Pin
117	350 562 99	1	Schmiernippel	Grease nipple
118	511 617 98	1	Klappstecker	Fore lock
119	638 840 40	2	Rohr	Pipe
121	631 804 40	1	Seilrolle	Sheave
122	005 221 98	1	Lager	Bearing
123	505 941 98	2	Sprengring	Snap ring
126	115 774 12	1	Führung	Guide
127	116 259 12	1	Stromschiene	Current rail
128	340 462 99	2	Scheibe	Washer
129	320 941 99	1	Schraube	Screw
130	320 942 99	2	Schraube	Screw
			* Meterware, bei Bestellung Länge angeben	* Bulk ware, state length required
*	509 649 98	-	Kette	Chain

**4. Innenkasten mit Rollenkopf**  
**4th. Inner Case with Sheave Head**

**187-6035b**

Seite/Page 7 / 7