

188-1903b

Seite/Page 1 / 5

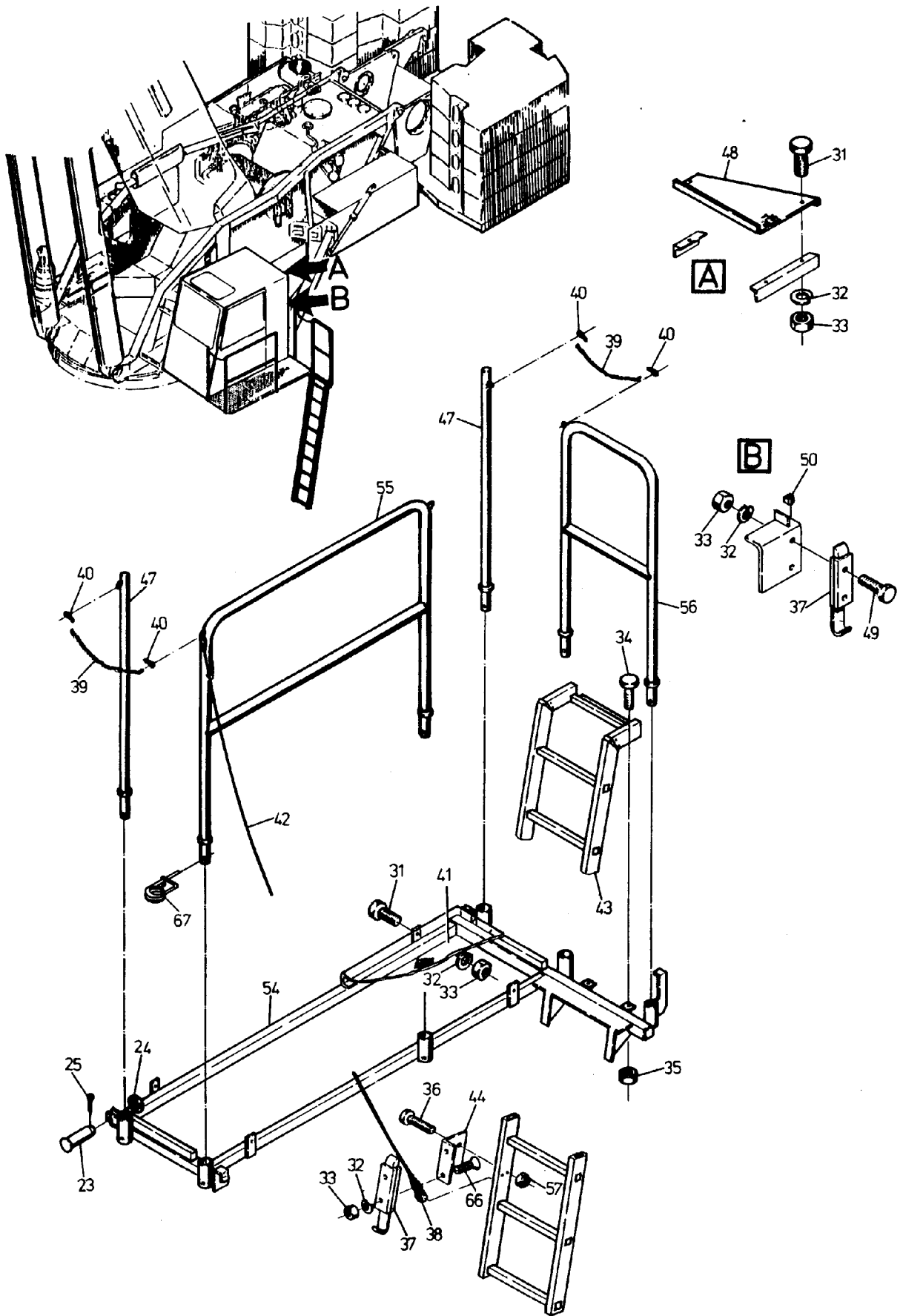

188-1903b

Seite/Page 2 / 5

Bild-Nr Fig Fig Fig Fig Bild nr	ET-Nr Part-No No. de Piece No. de Pieza No. del Pezzo Detalj nr	Stückzahl Qty Qte Ctd Qta Antal		Gegenstand Description Designation Descripcion Designazione Benaemning
01	458 702 40	1	Schwenkarm, kpl. (best. aus Bild-Nr. 02-14)	Swinging arm assy. (consist. of fig-nos: 02-14)
02	458 483 40	1	Schwenkarm, SK	Swinging arm
03	446 263 40	1	Konsole, SK	Console
04	446 283 40	1	Bolzen	Pin
05	342 675 99	1	Sicherungsring	Circlip
06	307 802 99	4	Schraube	Bolt
07	307 804 99	2	Schraube	Bolt
08	446 284 40	1	Deckel	Cover
09	446 442 40	1	Ring	Ring
10	446 457 40	1	Stützscheibe	Supporting disk
11	500 162 98	2	Kugellager	Ball bearing
12	342 690 99	2	Sicherungsring	Circlip
13	506 333 98	2	Kugellager	Ball bearing
17	495 844 40	2	Anti-Rutschbelag bis 88037	Safety rubber
18	458 578 40	2	Bolzen	Pin
19	340 623 99	2	Scheibe	Washer
20	342 121 99	2	Splint	Cotter pin
21	458 591 40	1	Bolzen	Pin
22	340 619 99	2	Scheibe	Washer
23	446 452 40	2	Bolzen	Pin
24	340 613 99	4	Scheibe	Washer
25	342 081 99	4	Splint	Cotter pin
26	307 821 99	4	Schraube	Bolt
27	307 822 99	3	Schraube ø 16	Bolt
27	307 587 99	3	Schraube ø 12	Bolt
28	446 282 40	1	Deckel	Cover
29	446 443 40	1	Ring	Ring
30	458 593 40	1	Bolzen	Pin
31	307 752 99	7	Schraube	Bolt
32	343 094 99	11	Federring	Lock washer
33	332 111 99	9	Mutter	Nut
34	500 853 98	2	Schraube	Bolt
35	332 113 99	2	Mutter	Nut
36	307 312 99	2	Schraube	Bolt
37	343 801 40	2	Federriegel	Twist lock
38	313 500 99	1	Ringschraube (Schweißteil)	Eyebolt (weld on part)
39	*	-	Kette	Chain
40	341 271 40	4	Karabinerhaken	Trigger snap
41	440 514 40	1	Sicherheitsrost	Safety grating

Bild-Nr Fig Fig Fig Fig Bild nr	ET-Nr Part-No No. de Piece No. de Pieza No. del Pezzo Detalj nr	Stückzahl Qty Qte Ctd Qta Antal		Gegenstand Description Designation Descripcion Designazione Benaemning
42	*	-	Seil	Rope
43	446 394 40	1	Leiter	Ladder
44	446 444 40	1	Winkel	Angle
45	440 515 40	1	Zylinder	Cylinder
47	446 105 40	2	Holm	Levelling arm
48	446 639 40	1	Trittlech	Step
49	307 757 99	2	Schraube	Bolt
50	207 649 40	1	Kantenprofil	Profile rubber
51	458 721 40	4	Rohr	Pipe
53	649 454 40	2	Absteckbolzen	Lock pin
54	446 124 40	1	Podest	Podest
55	446 143 40	1	Geländer	Rail
56	446 147 40	1	Geländer	Rail
57	504 212 98	2	Mutter	Nut
59	649 453 40	1	Arretierungsstück (Schweißteil)	Locking piece (weld on part)
60	515 999 40	1	Zylinder	Cylinder
61	440 517 40	1	Zylinder	Cylinder
62	446 441 40	2	Bolzen,bis Bau-Nr. 88 016	Pin, up to s/no: 88 016
62	496 050 40	2	Bolzen,ab Bau-Nr. 88 017	Pin, from s/no: 88 017 up
63	340 610 99	2	Scheibe	Washer
64	342 101 99	4	Splint	Cotter pin
65	458 414 40	2	Bolzen	Pin
66	320 433 99	2	Schraube	Screw
67	001 645 98	6	Sicherungsfeder	Locking spring
75	484 058 40	1	Haltestange *	Stay bar
76	484 059 40	2	Bolzen *	Pin
77	007 266 98	2	Sicherungsfeder *	Locking spring
78	461 835 40	1	Ratschengurt *	Safety belt
			* Bild-Nr. 75-78 Transporthalterung	* Fig-nos: 75-78 move suspension
80	307 427 99	6	Schraube	Bolt
81	490 121 40	1	Sicherheitsrost ab 88 003	Safety grating from s/no: 88 003
81	490 287 40	1	Sicherheitsrost ab 88 013	Safety grating from s/no: 88 013
81	635 355 40	1	Sicherheitsrost ab 88 037	Safety grating from s/no: 88 037
85	451 088 40	1	Spanner	Tightener
86	501 173 98	2	Schäkel	Clevis
87	007 266 98	2	Sicherungsfeder	Locking spring
100	690 197 73	2	Dichtsatz (zu Bild-Nr. 45,60)	Seal kit (to fig-nos: 45,60)
101	690 198 73	1	Dichtsatz (zu Bild-Nr. 61)	Seal kit (to fig-no: 61)

Bild-Nr Fig Fig Fig Fig Bild nr	ET-Nr Part-No No. de Piece No. de Pieza No. del Pezzo Detalj nr	Stückzahl Qty Qte Ctd Qta Antal	Gegenstand Description Designation Descripcion Designazione Benaemning
---	---	---	--

			* Meterware, bei Bestellung Länge angeben	* Bulk ware, state length required
* 506 625 98	-	Kette	Chain	
* 012 548 74	-	Seil	Rope	