

188-6040e

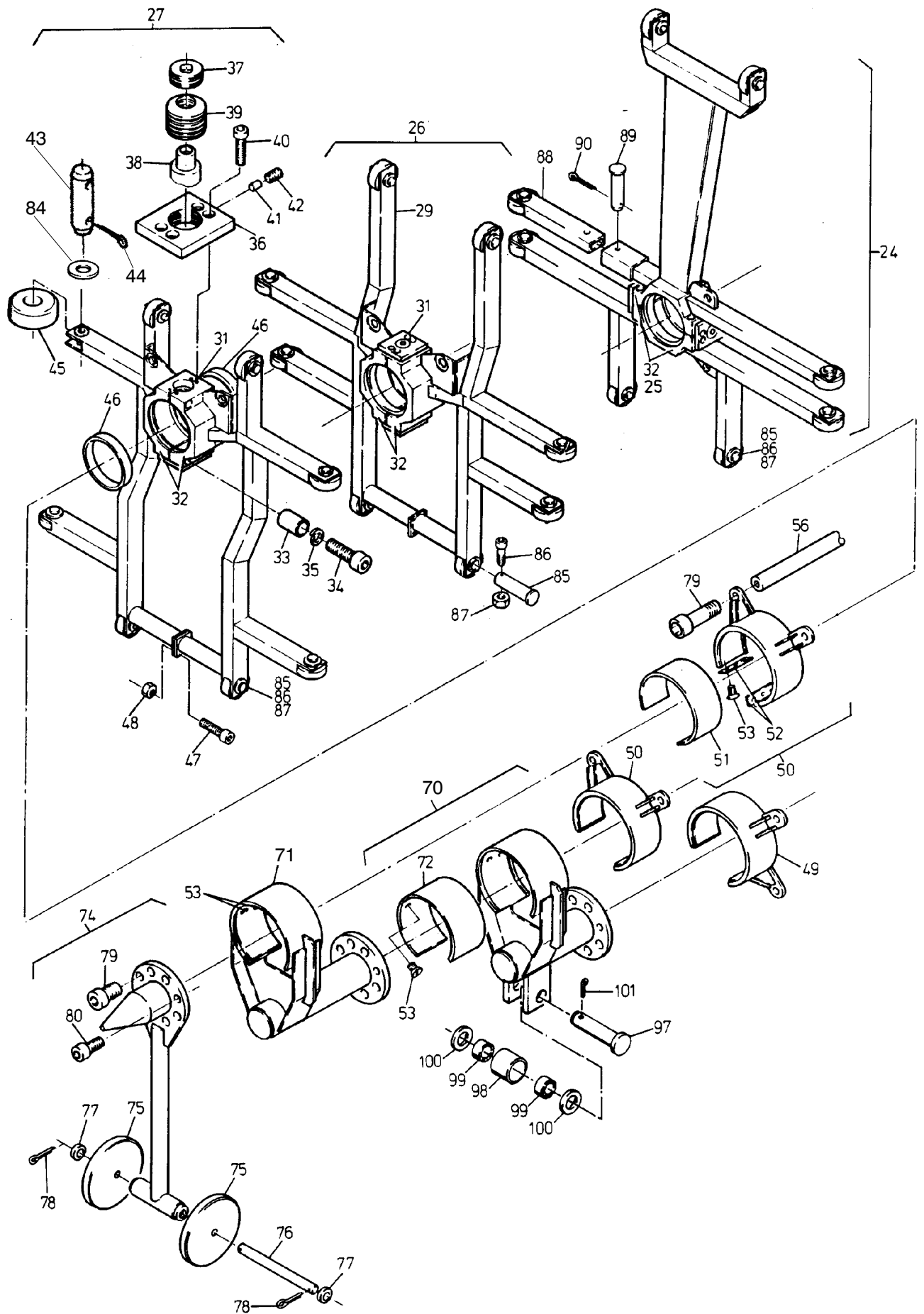

188-6040e

Bild-Nr Fig Fig Fig Fig Bild nr	ET-Nr Part-No No. de Piece No. de Pieza No. del Pezzo Detalj nr	Stückzahl Qty Qte Ctd Qta Antal		Gegenstand Description Designation Descripción Designazione Benaemning
			Bild 1	Graphic 1
01	-	1	Teleskopierzylinder I, . siehe EL-Blatt 188-6041b	Telescopic cylinder I see page 188-6041b
02	-		Teleskopierzylinder II siehe EL-Blatt 188-6041b	Telescopic cylinder II see page 188-6041b
03	-	1	Teleskopierzylinder III siehe EL-Blatt 188-6042	Telescopic cylinder III see page 188-6042
14	602 862 40	3	Bolzen	Pin
15	602 861 40	3	Achshalter	Axle stirrup
16	307 314 99	12	Schraube	Bolt
17	342 668 99	6	Sicherungsring	Circlip
18	447 643 40	2	Distanzrohr	Distance sleeve
19	408 976 40	6	Zylinderbolzen	Pin
20	447 642 40	4	Distanzrohr	Distance sleeve
21	447 641 40	6	Gleitstück	Slider
22	318 385 99	24	Schraube	Screw
23	549 716 40	6	Distanzrohr	Distance sleeve
			Bild 2	Graphic 2
24	446 308 40	1	Zylinderstütze (best. aus Bild-Nr. 25,30-35,37-46,88-90)	Bracket (consist. of fig-nos: 25,30-35,37-46,88-90)
25	495 351 40	2	Deckel	Cover
26	446 309 40	1	Zylinderstütze (best. aus Bild-Nr. 29,31-48,85-87)	Bracket (consist. of fig-nos: 29,31-48,85-87)
27	446 311 40	1	Zylinderstütze (best. aus Bild-Nr. 28,31-48,85-87)	Bracket (consist. of fig-nos: 28,31-48,85-87)
28	446 312 40	1	Zylinderstütze, SK	Bracket
29	446 310 40	1	Zylinderstütze, SK	Bracket
30	446 307 40	1	Zylinderstütze, SK	Bracket
31	446 313 40	3	Lager, kpl. (best. aus Bild-Nr. 32-35)	Bearing assy. (consist. of fig-nos: 32-35)
32	446 314 40	6	Lagerhälfte	Semi cup
33	335 623 40	3	Spannhülse	Dowel sleeve
34	319 288 40	12	Schraube	Bolt
35	343 817 99	12	Federring	Lock washer
36	446 317 40	4	Deckel	Cover
37	446 318 40	6	Schraube	Bolt
38	446 319 40	6	Kolben	Piston
39	440 487 40	36	Tellerfeder	Cup spring
40	319 147 99	24	Schraube	Bolt
Teleskopierzylinder-Einbau Telescopic Arr.				188-6040e
				Seite/Page 3 / 4

Bild-Nr Fig Fig Fig Fig Bild nr	ET-Nr Part-No No. de Piece No. de Pieza No. del Pezzo Detalj nr	Stückzahl Qty Qte Ctd Qta Antal		Gegenstand Description Designation Descripcion Designazione Benaemning
41	367 204 40	6	Bolzen	Pin
42	500 872 98	6	Gewindestift	Thread pin
43	564 070 40	16	Bolzen	Pin
44	342 082 99	32	Splint	Cotter pin
45	446 316 40	22	Stützrolle	Roller
46	440 486 40	6	Führungsring	Guide ring
47	319 141 99	8	Schraube	Screw
48	332 111 99	8	Mutter	Nut
49	447 335 40	1	Halterung, kpl. (einschl. Bild-Nr. 51-53)	Holding device assy. (incl. fig-nos: 51-53)
50	446 349 40	2	Halterung, kpl. (einschl. Bild-Nr. 51-53)	Holding device assy. (incl. fig-nos: 51-53)
51	446 354 40	3	Gleitstück	Slider
52	435 932 40	6	Gleitstück	Slider
53	318 379 99	18	Schraube	Screw
56	447 598 40	6	Zugstange, kpl.	Draw bar assy.
70	447 570 40	1	Zylinderführung I/II, kpl. (einschl. Bild-Nr. 72,97-101)	Cylinder guide I/II assy. (incl. fig-no: 72,97-101)
71	447 554 40	1	Zylinderführung II/III, kpl. (einschl. Bild-Nr. 72)	Cylinder guide II/III assy. (incl. fig-no: 72)
72	447 552 40	2	Gleitstück	Slider
74	447 582 40	1	Zylinder-Aufnahme, kpl. (einschl. Bild-Nr. 75-78)	Pivot assy. (incl. fig-nos: 75-78)
75	447 606 40	2	Rad	Wheel
76	447 607 40	1	Bolzen	Pin
77	340 613 99	2	Scheibe	Washer
78	342 081 99	2	Splint	Cotter pin
79	321 426 99	30	Schraube	Bolt
80	319 301 99	6	Schraube	Bolt
84	340 470 99	20	Scheibe	Washer
85	459 041 40	6	Bolzen	Pin
86	319 134 99	6	Schraube	Screw
87	332 110 99	6	Mutter	Nut
88	485 688 40	1	Hohlprofil	Hollow profile
89	500 702 98	1	Bolzen	Pin
90	342 062 99	1	Splint	Cotter pin
97	469 154 40	1	Bolzen	Pin
98	469 152 40	1	Rolle	Roller
99	362 702 99	2	Pendelrollenlager	Self-aligning bearing
100	469 156 40	2	Scheibe	Disc
101	342 105 99	1	Splint	Cotter pin

**Teleskopierzylinder-Einbau
Telescopic Arr.**

188-6040e

Seite/Page 4 / 4