

213-1235a

Seite/Page 1 / 3

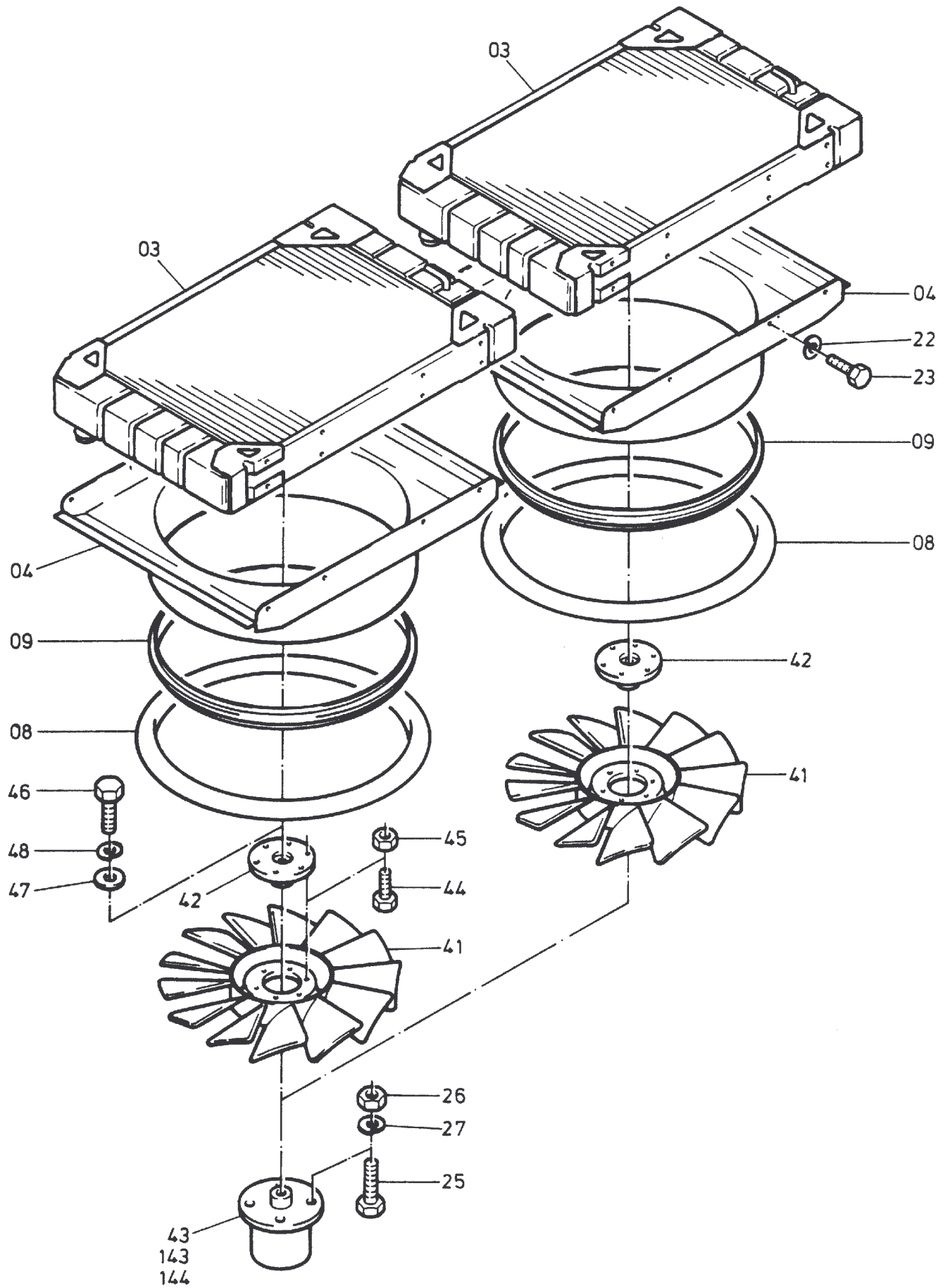

213-1235a

Seite/Page 2 / 3

Bild-Nr Fig Fig Fig Fig Bild nr	ET-Nr Part-No No. de Piece No. de Pieza No. del Pezzo Detalj nr	Stückzahl Qty Qte Ctd Qta Antal		Gegenstand Description Designation Descripcion Designazione Benaemning
01	349 940 40	1	Kühlerrahmen	Radiator frame
03	350 033 40	2	Kühler	Cooler
04	349 941 40	2	Luftleitblech	Spoiler
05	349 900 40	1	Verkleidung	Covering
06	349 916 40	1	Verkleidung	Covering
07	349 917 40	1	Tür	Door
08	350 052 40	2	Ring	Ring
09	263 156 40	2	Lüfterzarge	Ventilator
10	180 981 40	8	Megi-Puffer	Silent bloc
11	350 055 40	5	Gitterrost	Grating
12	316 847 40	2	Scharnier	Hinge
15	332 197 99	16	Mutter	Nut
16	346 500 99	16	Federring	Lock washer
17	004 703 98	11	Schraube	Screw
18	350 019 40	6	Nietmutter	Nut
19	348 635 40	5	Nietmutter	Nut
20	270 722 40	4	Blindbolzen	Dummy bolt
21	307 729 99	16	Schraube	Screw
22	343 085 99	32	Federring	Lock washer
23	307 728 99	16	Schraube	Screw
24	340 506 99	32	Scheibe	Washer
25	307 346 99	8	Schraube	Screw
26	335 412 99	8	Mutter	Nut
27	343 112 99	8	Federring	Lock washer
28	320 819 99	8	Schraube	Screw
29	350 766 99	8	Scheibe	Washer
30	340 408 99	16	Scheibe	Washer
31	296 638 40	20	Gitterrostklammer	Grating clamp
32	320 068 99	20	Mutter	Nut
35	307 280 99	20	Schraube	Screw
41	263 055 40	2	Lüfter	Ventilator
42	315 609 40	2	Flansch	Flange
43	315 610 40	2	Hydro-Zahnradmotor	Hydr. gear motor
44	307 312 99	12	Schraube	Screw
45	334 673 99	12	Mutter	Nut
46		2	Schraube	Screw
	005 839 98		bis Bau-Nr. 35 028	up to s/no: 35 028
	501 426 98		ab Bau-Nr. 35 029	from s/no: 35 029
47	243 988 40	2	Scheibe	Washer
48	343 108 99	2	Federring	Lock washer
143	964 797 00	1	Dichtsatz	Seal kit
144	966 988 00	1	Reparatursatz	Repair kit

**Wasserkühlereinbau
Radiator Mounting**

213-1235a

Seite/Page 3 / 3