

**Detail X**

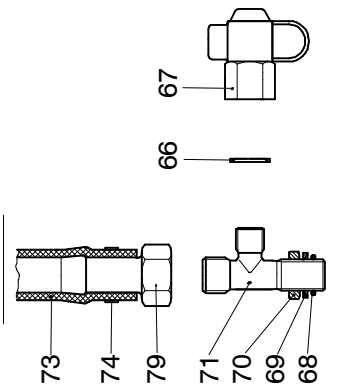

**Detail Y**

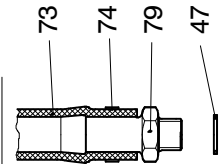

**222-1700**

Bild-Nr Fig Fig Fig Fig Bild nr	ET-Nr Part-No No. de Piece No. de Pieza No. del Pezzo Detalj nr	Stückzahl Qty Qte Ctd Qta Antal		Gegenstand Description Designation Descripcion Designazione Benaeming
01	634 376 40	1	Lufttrockner	Air dryer
-	761 176 73	1	Kartusche zu Bild-Nr. 01	Cartouche to fig-no: 01
02	502 836 98	2	Ventil	Valve
03	192 163 40	1	Rückschlagventil	Non-return valve
05	634 378 40	1	4-Kreis-Schutzventil	4-Way safety valve
06	192 147 40	1	Schlauchleitung	Hose assy.
07	576 196 40	1	Druckluftbehälter 10 ltr.	Pressure tank
08	576 197 40	2	Druckluftbehälter 20 ltr.	Pressure tank
09	576 198 40	1	Druckluftbehälter 30 ltr.	Pressure tank
10	576 199 40	4	Druckluftbehälter 40 ltr.	Pressure tank
11	087 257 40	8	Entwässerungsventil	Drain valve
12	440 834 40	4	Tristop-Zylinder	Tri-stop cylinder
13	324 053 40	1	Motorwagen-Bremsventil	Engine compartment - brake valve
14	224 189 40	1	Bremslichtschalter	Brake light switch
15	551 249 40	1	Handbremsventil	Hand brake valve
-	401 506 12	-	Reparatur-Satz zu Bild-Nr. 15	Repair kit to fig-no: 15
16	324 048 40	8	Membran-Bremszylinder	Diaphragm brake cylinder
17	180 265 40	1	Verschraubung	Union
18	388 717 40	1	Druckschalter	Pressure switch
19	461 361 40	4	Tristop-Zylinder	Tri-stop cylinder
20	551 155 40	4	Relaisventil	Solenoid
21	634 377 40	2	Relaisventil	Solenoid
22	192 161 40	2	Druckschalter	Pressure switch
23	604 025 40	16	Kronenmutter	Castel nut
24	215 812 99	-	Rohr 18x1,5, Länge angeben	Pipe, state length required
25	634 425 40	7	Geräuschdämpfer	Noise absorber
26	215 424 99	-	Rohr 12x1,5, Länge angeben	Pipe, state length required
27	501 019 98	-	Kunststoffrohr 10x1, Länge angeben	Plastic pipe, state length required
28	211 303 99	-	Kunststoffrohr 15x1,5 Länge angeben	Plastic pipe, state length required
29	211 302 99	-	Kunststoffrohr 12x1,5 Länge angeben	Plastic pipe, state length required
30	551 531 40	2	Stutzen	Socket
31	551 404 40	2	Stutzen	Socket
32	003 288 98	4	Schelle	Clamp
34	511 169 98	3	Stutzen	Socket
35	576 442 40	3	Stutzen	Socket
36	234 352 40	12	Dichtring	Seal ring

**Bremsanlage  
Brake System**

**222-1700**

Seite/Page 3 / 5

Bild-Nr Fig Fig Fig Fig Bild nr	ET-Nr Part-No No. de Piece No. de Pieza No. del Pezzo Detalj nr	Stückzahl Qty Qte Ctd Qta Antal		Gegenstand Description Designation Descripcion Designazione Benaemning
37	551 451 40	11	Stutzen	Socket
38	621 798 40	1	Pedalüberzug	Pedal pad
39	192 175 40	1	Dichtring	Seal ring
40	509 590 98	5	Stutzen	Socket
42	551 987 40	1	Stutzen	Socket
43	372 802 99	20	Verschraubung	Union
44	007 575 98	6	Hülse	Sleeve
46	244 819 40	12	Verschraubung	Union
47	192 183 40	38	Dichtung	Seal
48	510 222 98	8	Stutzen	Socket
49	502 335 98	-	Kunststoffrohr 6x1, Länge angeben	Plastic pipe, state length required
50	551 444 40	7	Stutzen	Socket
51	509 550 98	6	Stutzen	Socket
52	634 303 40	1	Stutzen	Socket
53	551 617 40	2	Stutzen	Socket
54	511 015 98	8	Stutzen	Socket
55	956 808 40	1	Verschraubung	Union
56	192 198 40	1	Dichtring	Seal ring
57	192 168 40	8	Prüfanschluß	Test point
58	551 447 40	1	Stutzen	Socket
59	192 201 40	7	Druckring	Thrust collar
60	192 202 40	7	O-Ring	O-ring
61	244 823 40	3	Verschraubung	Union
62	551 635 40	2	Stutzen	Socket
63	313 120 99	1	Verschlußschraube	Plug
64	592 069 40	2	Stutzen	Socket
65	313 194 99	4	Verschlußschraube	Plug
66	234 556 40	10	Dichtring	Seal ring
67	234 679 40	10	Prüfanschluß	Test point
68	224 301 40	10	O-Ring	O-ring
69	224 299 40	10	Druckring	Thrust collar
70	234 555 40	10	Gegenmutter	Counter nut
71	234 680 40	10	Stutzen	Socket
72	224 302 40	40	Schlauchstutzen	Hose connection
73	255 045 40	-	Schlauch 11x4, Länge angeben	Hose, state length required
74	007 666 98	48	Schlauchschele	Hose clip
75	551 374 40	4	Stutzen	Socket
76	551 615 40	1	Stutzen	Socket
78	551 380 40	4	Stutzen	Socket

**Bremsanlage  
Brake System**

**222-1700**

Seite/Page 4 / 5

Bild-Nr Fig Fig Fig Bild nr	ET-Nr Part-No No. de Piece No. de Pieza No. del Pezzo Detalj nr	Stückzahl Qty Qte Ctd Qta Antal		Gegenstand Description Designation Descripcion Designazione Benaemning
79	224 194 40	20	Schlauchstutzen	Hose connection
80	323 204 40	12	Verschraubung	Union
81	243 645 40	4	Verschraubung	Union
82	243 644 40	2	Stutzen	Socket
83	551 456 40	1	Stutzen	Socket
84	509 811 98	5	Stutzen	Socket
85	208 967 40	30	Hülse	Sleeve
86	501 540 98	65	Hülse	Sleeve
87	007 577 98	50	Hülse	Sleeve
88	551 449 40	2	Stutzen	Socket
89	576 468 40	2	Stutzen	Socket
95	145 812 40	12	Schelle	Clamp
96	166 556 40	10	Schelle	Clamp
97	047 356 40	16	Schelle	Clamp
98	551 301 40	8	Stutzen	Socket
102	592 590 40	2	Stutzen	Socket
104	432 190 40	1	Entlüftungsteil	Breather part
106	287 241 40	1	Geräuschdämpfer	Noise absorber
113	334 679 99	3	Mutter	Nut
114	340 467 99	3	Scheibe	Washer
115	373 907 99	4	Rohrschelle	Pipe clamp
118	308 252 99	2	Schraube	Bolt
119	346 510 99	2	Federring	Lock washer
120	332 208 99	1	Mutter	Nut
121	509 284 98	1	Schraube	Bolt
122	346 500 99	1	Federring	Lock washer
123	391 984 40	1	Halter	Retainer
			<b>Bremsdruckanzeige: JAPAN</b>	<b>Brake pressure indicator: JAPAN</b>
-	324 000 40	1	Doppelluftdruckmesser	Manometer, air pressure
-	323 542 40	2	T-Verschraubung	Tee-union
			weitere Rohrverschraubungen	further unions
			s. EL-Blatt 90-9998, Anhang	see page 90-9998, annex
			Rohre	Pipes
			s. EL-Blatt 90-9959, Anhang	see page 90-9959, annex
			Rohrschellen	Pipe clamps
			s. EL-Blatt 90-9995, Anhang	see page 90-9995, annex