

00

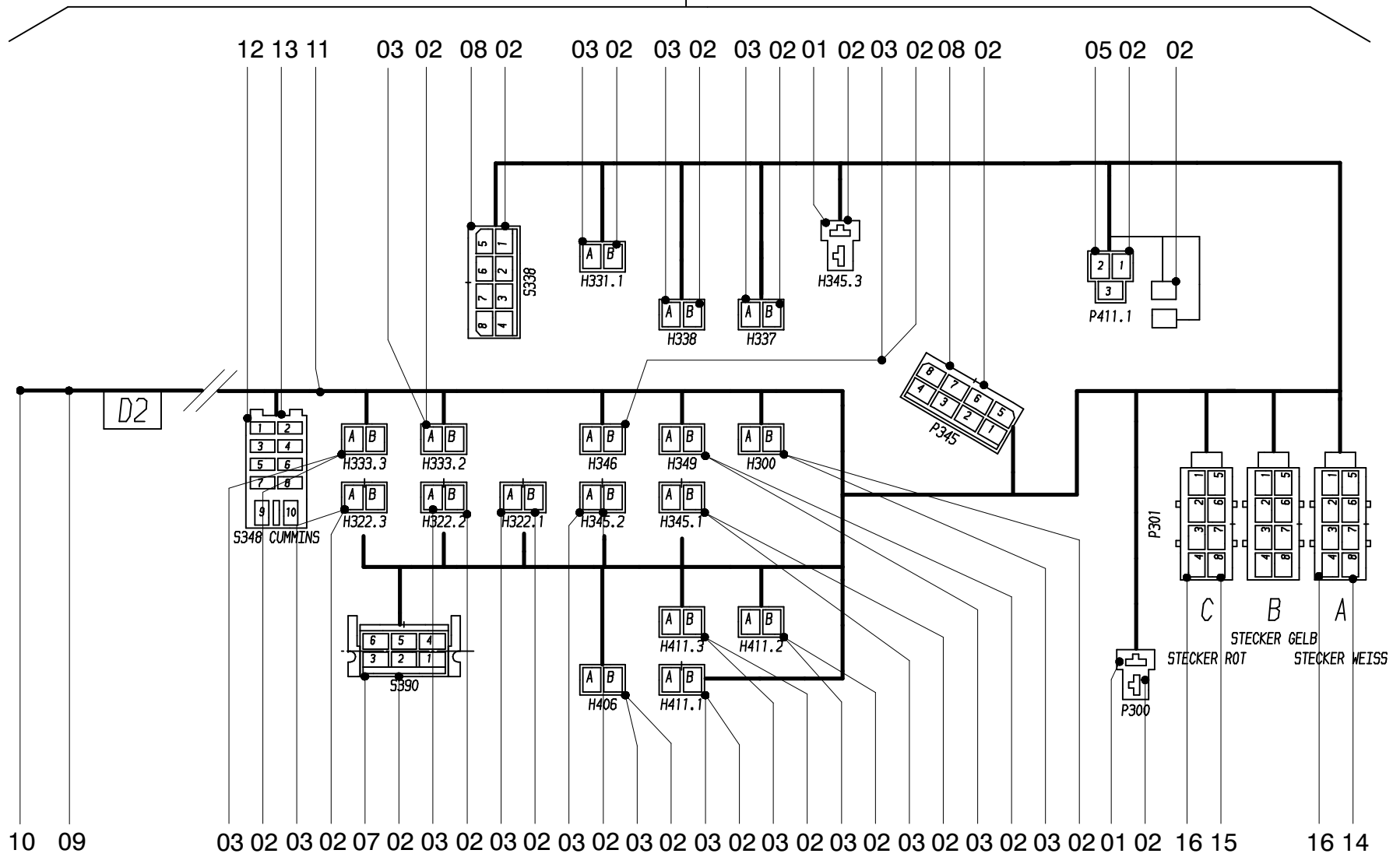

STECKER "B" IST DIE TACHOERFASSUNG DES GETRIEBES

222-2171a

Bild-Nr Fig Fig Fig Fig Bild nr	ET-Nr Part-No No. de Piece No. de Pieza No. del Pezzo Detalj nr	Stückzahl Qty Qte Ctd Qta Antal		Gegenstand Description Designation Descripcion Designazione Benaemning
00	874 022 40	1	Kabelbaum Armaturenbrett 2	Harness dash board 2
01	440 797 40	2	Steckhülsegehäuse 1-pol.	Female housing
02	057 251 40	64	Steckhülse	Sleeve
03	634 099 40	17	Steckhülsegehäuse 2-pol.	Female housing
05	634 898 40	1	Steckhülsegehäuse 3-pol.	Female housing
07	057 331 40	1	Steckhülsegehäuse 6-pol.	Female housing
08	047 014 40	2	Steckhülsegehäuse 8-pol.	Female housing
09	369 186 40	-	Kabel 65x1, 2,4 m lang	Cable
10	270 200 40	65	Schutzhülse	Grommet
11	056 292 40	8	Kabelband	Cable strap
12	604 460 40	1	Steckhülsegehäuse 10-pol.	Female housing
13	604 459 40	10	Doppelfederkontakt	Double spring contact
14	654 336 40	1	Steckhülsegehäuse 8-pol.	Female housing
15	654 338 40	1	Steckhülsegehäuse 8-pol.	Female housing
16	604 063 40	16	Steckhülsekontakt	Sleeve contact

**Kabelbaum Armaturenbrett 2
Harness Dash Board 2**

222-2171a

Seite/Page 2 / 2