

**24-2245**

Seite/Page 1 / 5

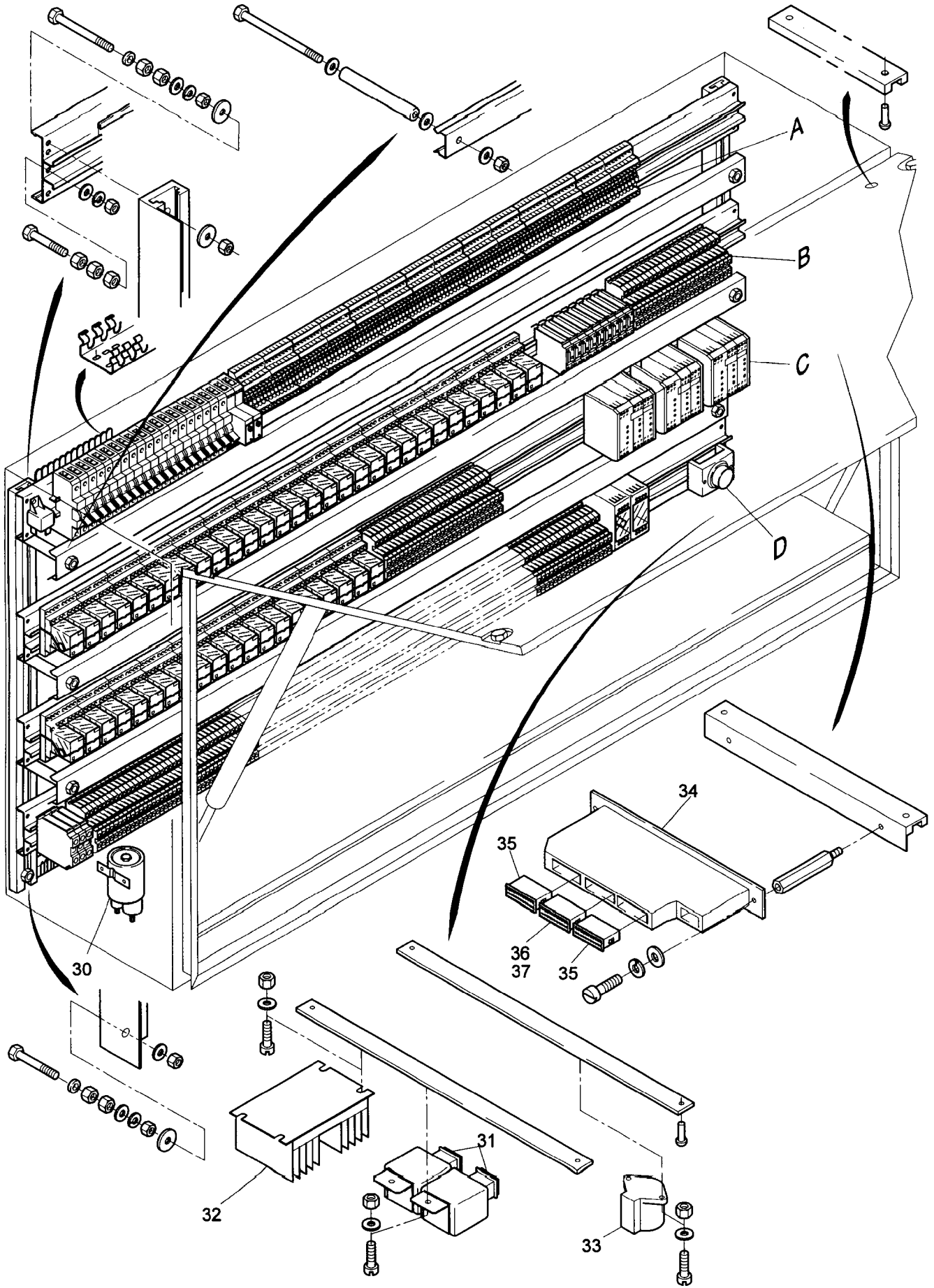



Bild-Nr Fig Fig Fig Fig Bild nr	ET-Nr Part-No No. de Piece No. de Pieza No. del Pezzo Detalj nr	Stückzahl Qty Qte Ctd Qta Antal		Gegenstand Description Designation Descripcion Designazione Benaemning
00	874 327 40	1	Schaltkasten, kpl.	Switch box assy.
01	551 517 40	1	Schaltkasten	Switch box
02	504 043 98	8	Schraube	Bolt
03	504 212 98	16	Mutter	Nut
04	440 940 40	14	Scheibe	Washer
05	002 825 98	4	Sicherung	Fuse
06	350 750 99	4	Gabelkopf	Fork end
07	081 267 40	1	Dornschlüssel	Arbor
08	324 444 99	2	Gewindestift	Threaded pin
09	340 464 99	2	Scheibe	Washer
10	137 273 40	3	Entlüftungsstutzen	Bleeder nozzle
11	600 806 99	3	Mutter	Nut
12	576 488 40	2	Gasfeder	Gas operated positioner
13	634 079 40	4	Anschlußarmatur	Fitting
14	*	-	Schutzwellrohr DN70	Corrugated pipe
15	320 068 99	20	Mutter	Nut
16	340 463 99	20	Scheibe	Washer
17	307 646 99	20	Schraube	Bolt
18	323 229 40	2	Tragschiene	Assembly rail
30	358 293 40	1	Leistungsrelais	Relay
31	461 251 40	2	Impulsgeber	Sender
32	551 334 40	1	Spannungswandler 24V/12V	Voltage converter
33	057 278 40	1	Steckdose	Socket
34	450 249 12	1	Motor-Elektronik (FMR)	Engine electronic
35	654 821 40	2	Steckhülsegehäuse 14-pol.	Female housing
36	654 822 40	1	Steckhülsegehäuse 18-pol.	Female housing
37	654 817 40	8	Kontaktfeder	Contact
50	180 221 40	1	Relais	Relay
51	323 770 40	1	Sicherungsautomat 1A	Breaker
52	323 769 40	15	Sicherungsautomat 6A	Breaker
53	343 843 40	2	Sicherungsautomat 10A	Breaker
54	323 768 40	1	Sicherungsautomat 16A	Breaker
55	000 319 12	2	Zeitrelais	Time lag relay
56	621 952 40	7	Diodenmodul	Diode assy.
58	346 528 40	25	Relaisbaustein	Relay modul
59	346 529 40	50	Relais	Relay
60	635 575 40	50	Haltebügel	Retainer
61	635 139 40	4	Abgleichklemme 1K Ohm	Equalizer terminal
62	324 058 40	3	Abgleichklemme 5K Ohm	Equalizer terminal
63	551 005 40	54	Relaiskoppler	Coupling relais

**Hauptschaltkasten X2**  
**Main Switch Cabinet X2**

**24-2245**

Seite/Page 4 / 5

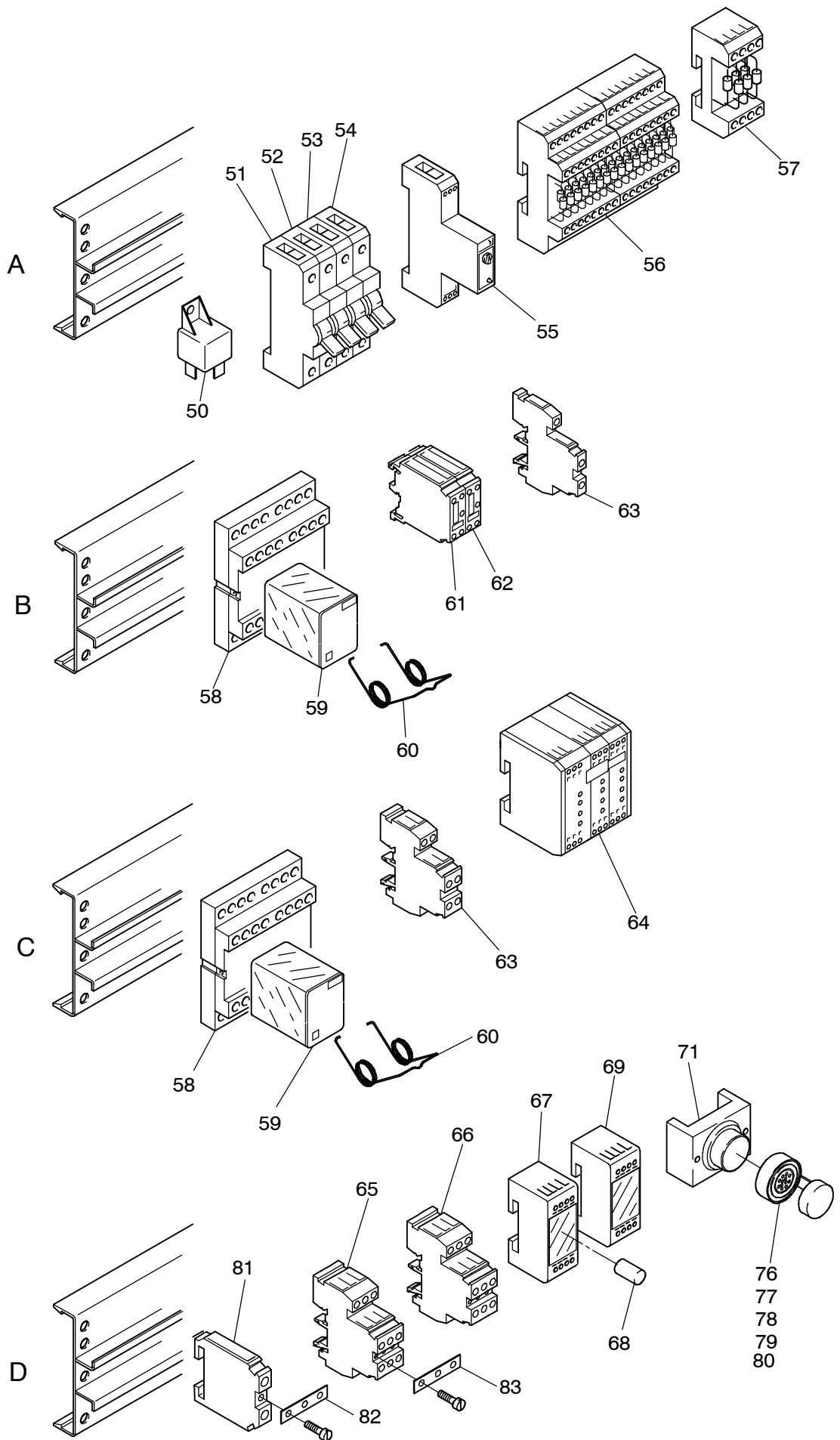
<b>Bild-Nr</b> Fig Fig Fig Fig Bild nr	<b>ET-Nr</b> Part-No No. de Piece No. de Pieza No. del Pezzo Detalj nr	<b>Stückzahl</b> Qty Qte Ctd Qta Antal		<b>Gegenstand</b> Description Designation Descripcion Designazione Benaemning
64	634 859 40	3	Verstärkermodul	Amplifier module
65	551 695 40	48	Reihenklemme	Series terminal
66	551 694 40	2	Reihenklemme	Series terminal
67	874 818 40	1	Handgas-Platine	Throttle hand modul
68	370 049 40	1	Kondensator	Capacitor
69	888 829 40	1	Festspannungsregler	Fixed voltage governor
71	889 578 40	1	Halter	Retainer
75	634 864 40	22	Steckhülse	Sleeve
76	654 816 40	1	Diagnosedose	Diagnosix box
77	654 826 40	1	Befestigungsring	Mounting ring
78	654 825 40	1	Staubkappe	Dust cap
79	654 827 40	1	Abstandsscheibe	Spacer shim
80	654 814 40	14	Kontaktbuchse	Female contact
81	576 005 40	3	Reihenklemme	Series terminal
82	576 006 40	1	Querverbinder	Cross connection
83	551 696 40	6	Querverbinder	Cross connection
			* Meterware, bei Bestellung Länge angeben	* Bulk ware, state length required
*	634 077 40	-	Schutzwelrohr DN70	Corrugated pipe