

24-6158

Seite/Page 1 / 4

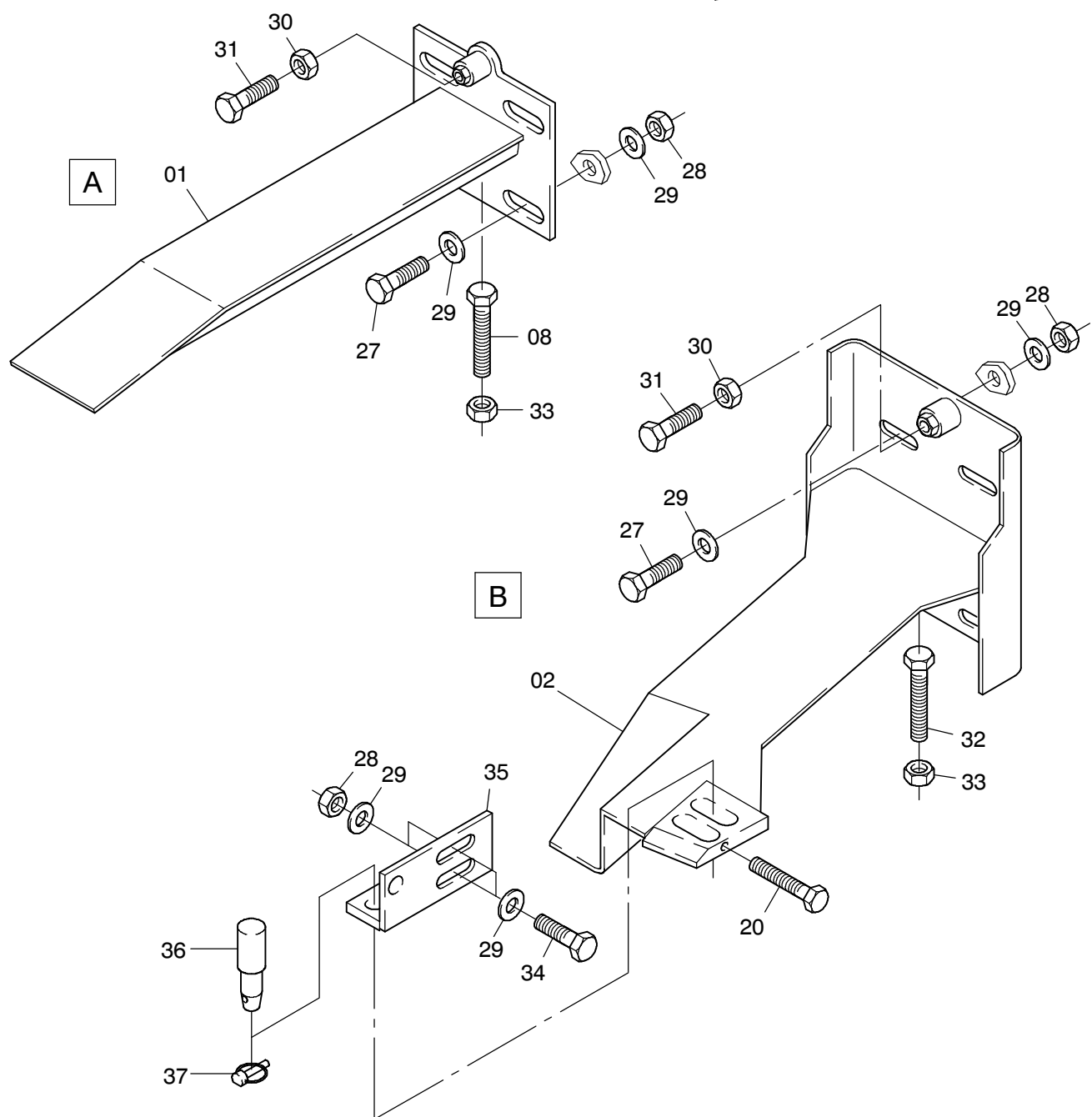
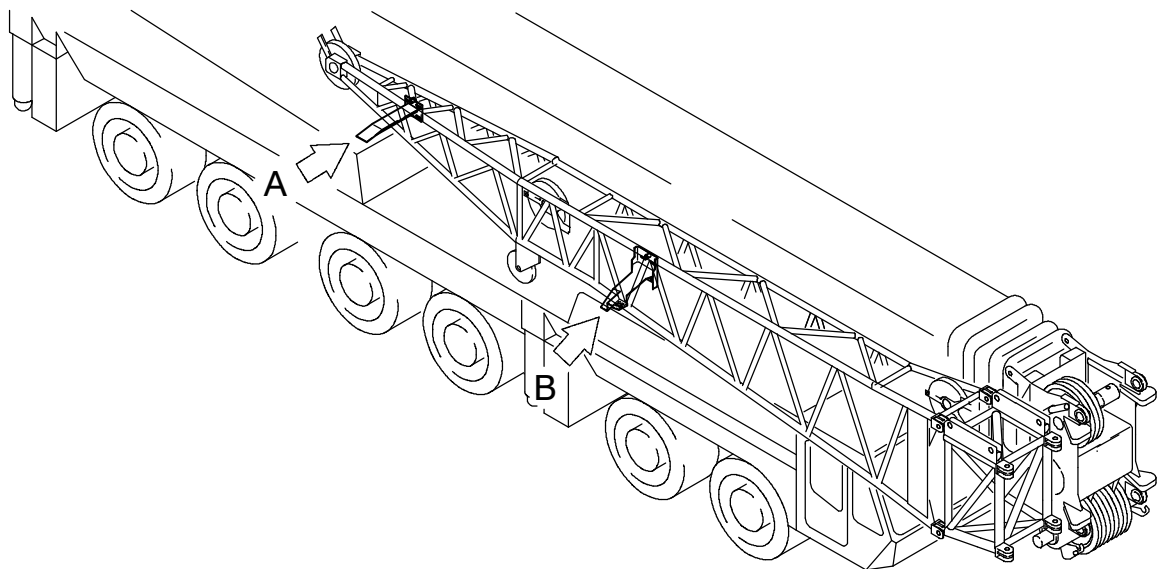

24-6158

Seite/Page 2 / 4

Bild-Nr Fig Fig Fig Fig Bild nr	ET-Nr Part-No No. de Piece No. de Pieza No. del Pezzo Detalj nr	Stückzahl Qty Qte Ctd Qta Antal		Gegenstand Description Designation Descripción Designazione Benaemning
01	885 144 40	1	Haltearm	Frame
02	679 890 40	1	Haltearm	Frame
04	649 420 40	2	Gewindeplatte	Thread plate
05	319 287 99	4	Schraube	Bolt
06	316 211 99	4	Scheibe	Washer
07	332 086 99	2	Mutter	Nut
08	307 837 99	3	Schraube	Bolt
09	639 503 40	1	Schild	Plate
10	307 402 99	2	Schraube	Bolt
11	648 992 40	1	Schaltfahne	Marker
12	320 143 99	1	Schraube	Screw
13	332 205 99	1	Mutter	Nut
14	-	1	Arbeitszylinder 1 siehe EL-Blatt 993-0450	Slave cylinder 1 see page 993-0450
15	450 870 40	1	Gelenkkopf	Knuckle
16	876 070 40	1	Haltestück	Retainer
17	679 276 40	1	Bolzen	Pin
18	511 617 98	1	Klappstecker	Fore lock
19	340 517 99	2	Scheibe	Washer
20	307 791 99	3	Schraube	Bolt
21	332 333 99	6	Mutter	Nut
22	461 128 40	1	Kupplungsbolzen	Pin
23	513 684 98	1	Nutmutter	Groove nut
24	307 403 99	2	Schraube	Bolt
25	350 766 99	2	Scheibe	Washer
26	321 814 99	2	Hutmutter	Cap nut
27	307 626 99	8	Schraube	Bolt
28	332 340 99	10	Mutter	Nut
29	340 471 99	20	Scheibe	Washer
30	332 338 99	2	Mutter	Nut
31	502 021 98	2	Schraube	Bolt
32	502 390 98	1	Schraube	Bolt
33	332 336 99	2	Mutter	Nut
34	307 883 99	2	Schraube	Bolt
35	876 147 40	1	Konsole	Console
36	876 146 40	1	Bolzen	Pin
37	461 665 40	1	Klappstecker	Fore lock
38	639 501 40	1	Schild	Plate
42	307 780 99	1	Schraube	Bolt
43	885 272 40	1	Beilageblech	Spacer
44	885 273 40	1	Beilageblech	Spacer

Bild-Nr Fig Fig Fig Fig Bild nr	ET-Nr Part-No No. de Piece No. de Pieza No. del Pezzo Detalj nr	Stückzahl Qty Qte Ctd Qta Antal		Gegenstand Description Designation Descripcion Designazione Benaemning
45	885 307 40	1	Beilageblech	Spacer
46	885 270 40	1	Beilageblech	Spacer
50	-	1	Verbolzungseinheit siehe EL-Blatt 39-6174	Pin locking unit see page 39-6174a