

24-6200

Seite/Page 2 / 5

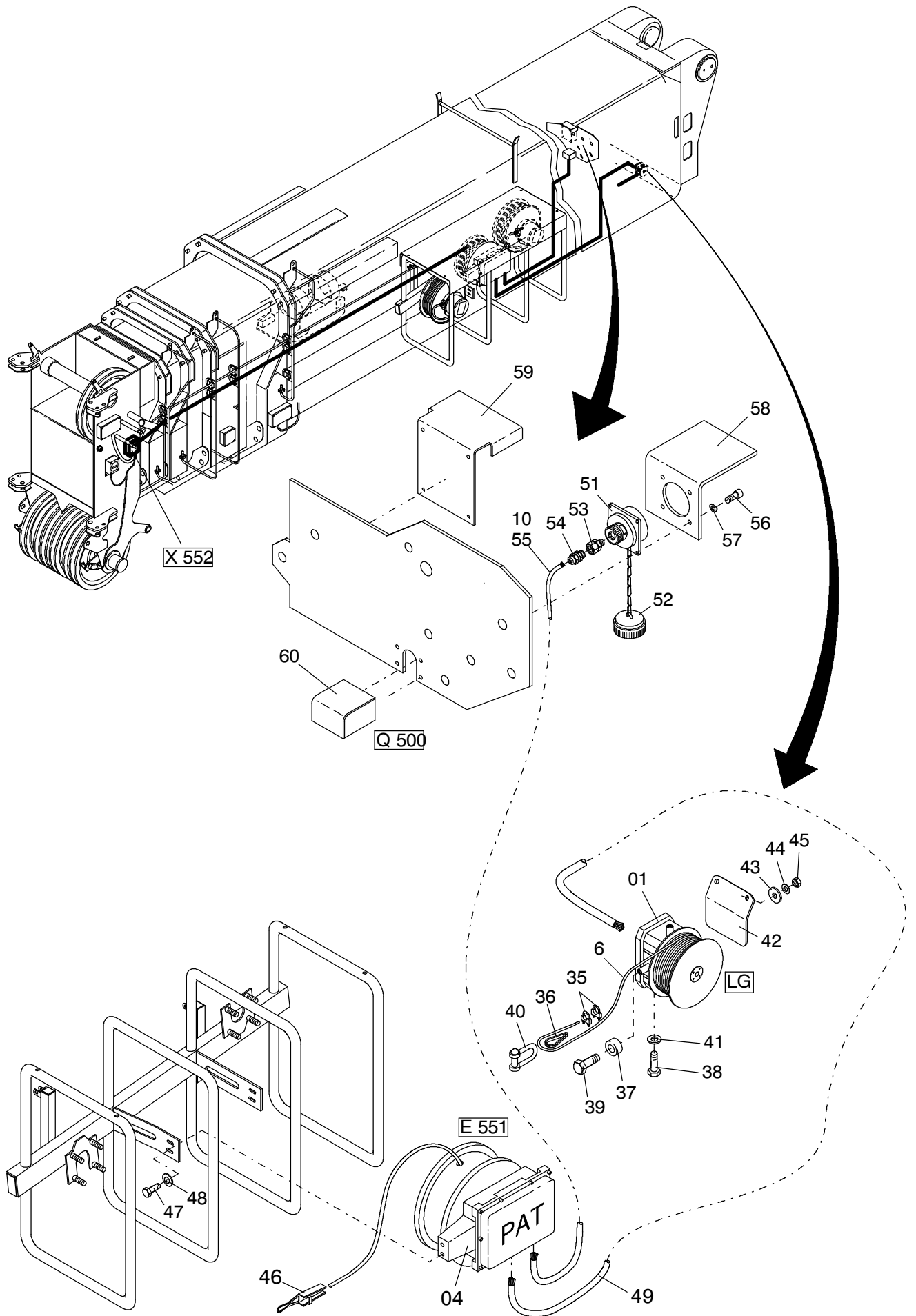

Bild-Nr Fig Fig Fig Fig Bild nr	ET-Nr Part-No No. de Piece No. de Pieza No. del Pezzo Detalj nr	Stückzahl Qty Qte Ctd Qta Antal		Gegenstand Description Designation Descripcion Designazione Benaemning
01	654 677 40	1	Längengeber	Length transmitter
02	635 192 40	1	Winkelgeber	Angle transmitter
03	888 378 40	1	Leitungstrommel kpl.	Cable drum assy.
04	635 189 40	1	Leitungstrommel siehe EI-Blatt 993-0726	Cable drum see page 993-0726
05	874 653 40	1	Leitungstrommel kpl.	Cable drum assy.
06	450 088 12	1	Längengeberseil 18 m	Length transmitter, rope
10	570 509 40	1	Kabel kpl.	Cable assy.
11	884 942 40	1	Trommelhalter	Bracket, drum
12	884 835 40	1	Abdeckung	Cover frame
13	308 554 99	4	Schraube	Bolt
14	334 626 99	4	Mutter	Nut
15	648 984 40	4	Bolzen	Pin
16	621 138 40	4	Klappstecker	Fore lock
17		16	Mutter	Nut
18	654 473 40	1	Leitungstrommel siehe EI-Blatt 993-0724	Cable drum see page 993-0724
19	621 928 40	-	Kabel 12 x 1	
20	395 976 40	2	Abspannklemme	Clamp
21	342 061 99	4	Splint	Cover pin
22	340 652 99	4	Scheibe	Washer
23	369 200 40	-	Kabel 14 x 1	Cable
24	369 775 40	-	Kabel 25 x 1	Cable
25	000 034 12	1	Leitungstrommel siehe EI-Blatt 993-0725	Cable drum see page 993-0725
26	621 929 40	-	Kabel 18 x 1	Cable
27	635 136 40	1	Steckersatz	Plug set
28	621 930 40	-	Kabel 5 x 0.5	Cable
29	058 332 40	2	Positionsleuchte	Positioninglight
30	507 372 99	2	Glühlampe	Bulb
31	369 198 40	-	Kabel 3 x 1	Cable
33	634 244 40	1	Arbeitsscheinwerfer	Spotlight
34	234 639 40	1	Glühlampe	Bulb
35	300 020 99	2	Seilklemme	Rope clamp
36	300 045 99	1	Seilkausche	Grummet
37	679 175 40	1	Buchse	Bush
38	307 729 99	1	Schraube	Bolt
39	307 410 99	1	Schraube	Bolt
40	509 431 98	1	Schäkel	Clevis
41	350 766 99	2	Scheibe	Washer
42	884 475 40	1	Abdeckung	Cover frame

Bild-Nr Fig Fig Fig Fig Bild nr	ET-Nr Part-No No. de Piece No. de Pieza No. del Pezzo Detalj nr	Stückzahl Qty Qte Ctd Qta Antal		Gegenstand Description Designation Descripcion Designazione Benaemning
43	340 697 99	2	Scheibe	Washer
44	506 948 98	2	Scheibe	Washer
45	509 861 98	2	Mutter	Nut
46	324 916 40	1	Abspannklemme	Clamp
47		4	Schraube	Bolt
48		4	Scheibe	Washer
49	621 930 40	-	Kabel 5 x 0.5	Cable
51	551 778 40	1	Steckdose	Socket
52	551 779 40	1	Staubkappe	Dust cap
53	414 529 40	1	Kabelverschraubung	Cable union
54	309 987 40	1	Kabelverschraubung	Cable union
55	270 666 40	-	Kabel 18 x 0.5	Cable
56	320 815 99	4	Schraube	Bolt
57	343 104 99	4	Scheibe	Washer
58	885 046 40	1	Abdeckung	Cover frame
59	884 746 40	1	Abdeckung	Cover frame
60	110 181 12	1	Abdeckung	Cover frame