

255-6113

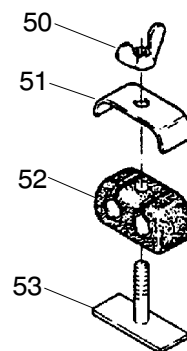
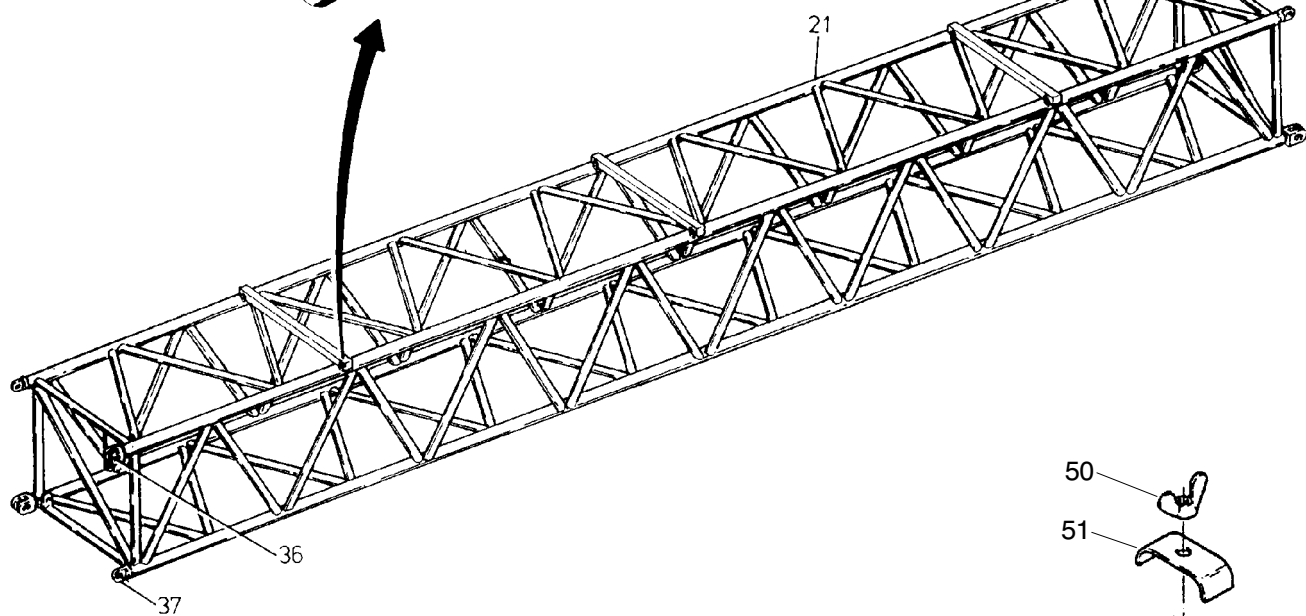
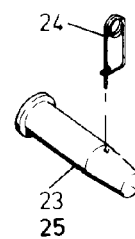
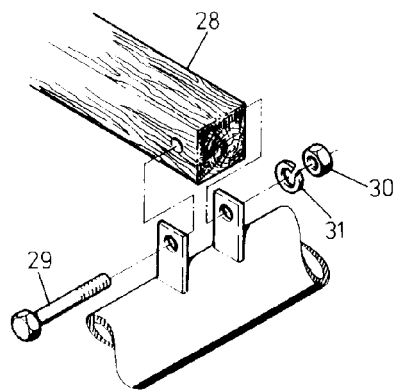
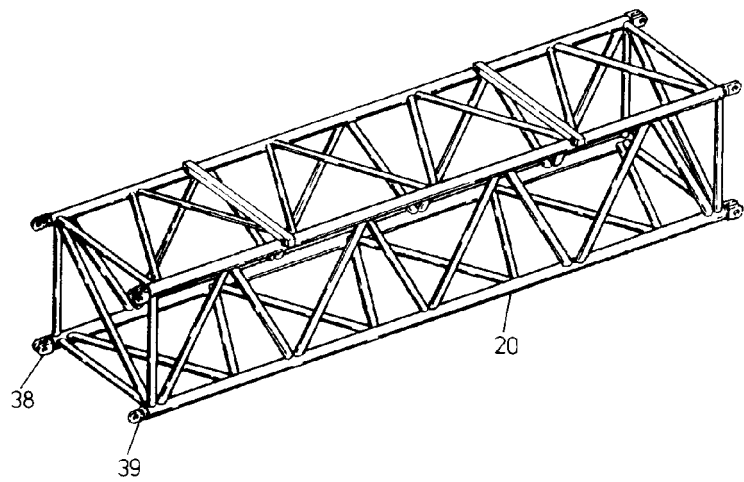

255-6113

Bild-Nr Fig Fig Fig Fig Bild nr	ET-Nr Part-No No. de Piece No. de Pieza No. del Pezzo Detailj nr	Stückzahl Qty Qte Ctd Qta Antal		Gegegenstand Description Designation Description Designazione Benaemning
			Bild 1	Graphic 1
00	444 786 40	1	Fußstück, kpl.	Bottom piece assy.
01	444 785 40	1	Fußstück, SK (ohne Anbauteile)	Bottom piece (w/o mounting parts)
02	150 718 40	2	Pendel	Pendulum
03	437 444 40	2	Bolzen	Pin
04	168 114 40	2	Bolzen	Pin
05	444 736 40	2	Scheibe	Disc
06	444 737 40	2	Buchse	Bush
07	150 716 40	2	Buchse	Bush
08	150 715 40	2	Bolzen	Pin
09	505 903 98	2	Sicherungsbolzen	Lock pin
10	350 567 99	6	Schmiernippel	Grease nipple
11	307 780 99	4	Schraube	Bolt
12	307 821 99	2	Schraube	Bolt
13	007 266 98	2	Sicherungsfeder	Locking spring
14	168 111 40	2	Endscheibe	End plate
			Bild 2	Graphic 2
20	442 403 40	-	Zwischenstück, 3m	Extension
21	369 784 40	-	Zwischenstück, 6m	Extension
23	003 061 98	-	Bolzen, ø 55x182	Pin
24	001 645 98	-	Sicherungsfeder	Locking spring
25	152 238 40	2	Bolzen ø 55x250 (zur Abspannstütze)	Pin (for brace)
28	369 782 40	2	Holzauflage	Wooden surface
29	308 584 99	4	Schraube	Bolt
30	332 197 99	4	Mutter	Nut
31	346 500 99	4	Federring	Lock washer
			Schweißteile zur Reparatur	Welding parts for repair
36	236 778 40	4	Gabelkopf	Fork end
37	236 766 40	4	Ösenkopf	Lug
38	236 779 40	4	Gabelkopf	Fork end
39	236 767 40	4	Ösenkopf	Lug
50	490 037 40	-	Bügel	Yoke
51	506 758 40	-	Flügelmutter	Wing nut
52	490 036 40	-	Gummiteil	Rubber
53	490 035 40	-	Anschweißplatte	Weld on plate
			* Meterware, bei Bestellung Länge angeben	* Bulk ware, state length required
			Rohre für Zwischenstücke	Pipes for extensions
-	214 234 99	-	Rohr, ø 101,6x12,5	Pipe
-	213 062 99	-	Rohr, ø 60,3x2,9	Pipe
Fußstück, Hilfsausleger (SW) 5,5m, Zwischenstück				255-6113
Bottom Piece, Jib Boom (SW) 5,5m, Extension				Seite/Page 3/4

Bild-Nr Fig Fig Fig Fig Bild nr	ET-Nr Part-No No. de Piece No. de Pieza No. del Pezzo Detailj nr	Stückzahl Qty Qte Ctd Qta Antal		Gegenstand Description Designation Descripcion Designazione Benaemning
-	500 925 98	-	Rohr, ø 70x2,9	Pipe
-	214 233 99	-	Rohr, ø 101,6x8	Pipe
-	080 213		Schweißelektrode ø 2,5 (1 Paket = 250 Stück)	Welding electrode (packed by 250)
-	080 214		Schweißelektrode ø 3,25 (1 Paket = 125 Stück)	Welding electrode (packed by 125)
Fußstück, Hilfsausleger (SW) 5,5m, Zwischenstück				255-6113
Bottom Piece, Jib Boom (SW) 5,5m, Extension				Seite/Page 4/4