

286-6213

Seite/Page 1 / 3

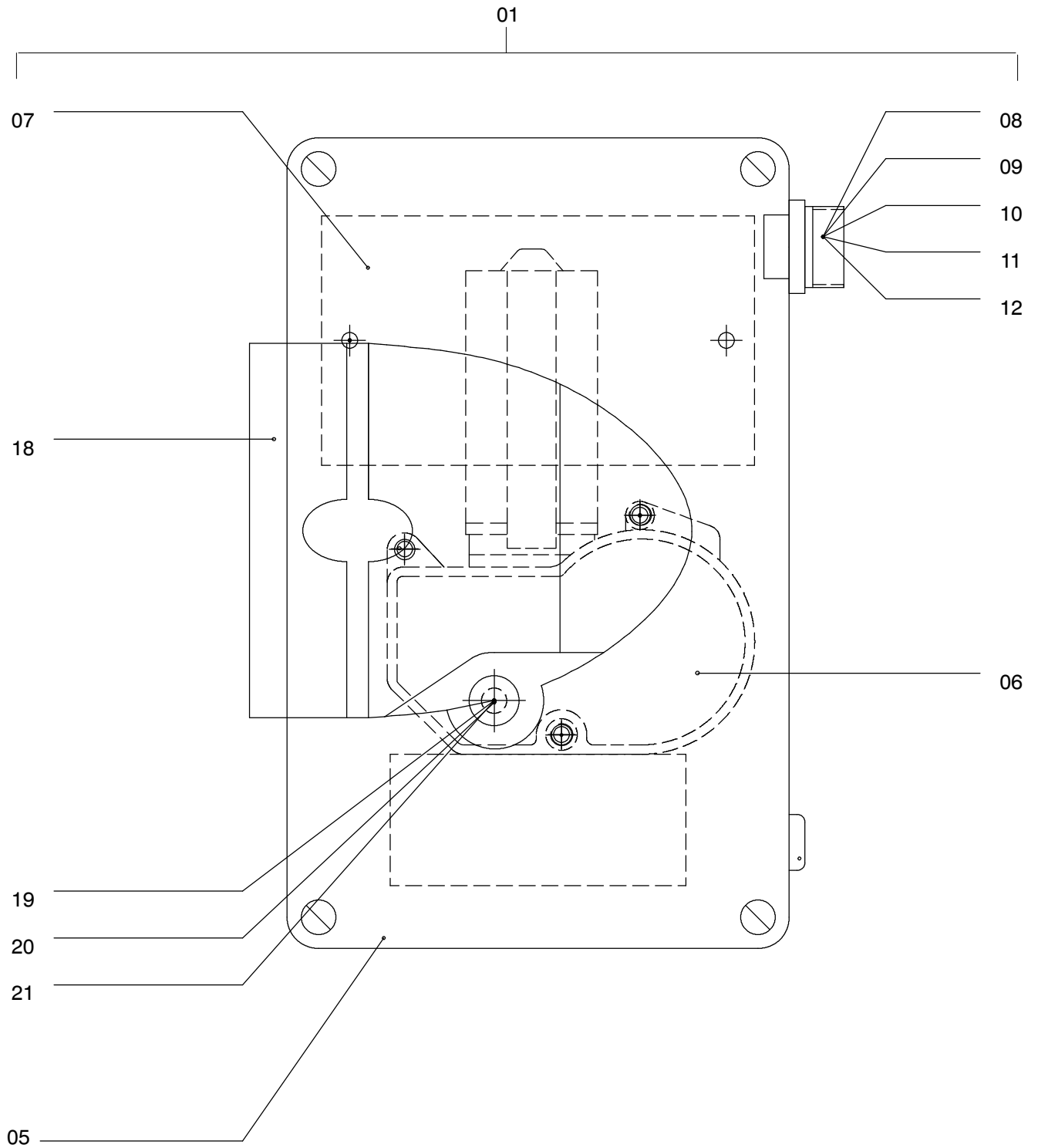

286-6213

Seite/Page 2 / 3

Bild-Nr Fig Fig Fig Fig Bild nr	ET-Nr Part-No No. de Piece No. de Pieza No. del Pezzo Detalj nr	Stückzahl Qty Qte Ctd Qta Antal		Gegenstand Description Designation Descripcion Designazione Benaemning
01	130 640 12	1	Arbeitsscheinwerfer kompl.	Spotlight assy.
02	164 225 12	1	Blech	Sheet
03	319 129 99	4	Schraube	Screw
05	130 631 12	1	Leergehäuse	
06	021 124 12	1	Motor	Motor
07	021 122 12	1	Steuerplatine	Control plate
08	047 247 40	1	Steckdose mit Flansch	Flanged socket
09	047 249 40	1	Verschlußdeckel	Cover
10	320 973 99	2	Schraube	Screw
11	509 858 98	2	Mutter	Nut
12	346 507 99	2	Federring	Spring washer
18	021 123 12	1	Scheinwerfer und Vor- schaltgerät	Spotlight and pre-resistor
19	133 034 12	1	Hülse	Sleeve
20	308 907 99	1	Schraube	Screw
21	440 940 40	2	Scheibe	Washer
22	509 829 98	2	Schraube	Bolt
23	340 509 99	1	Scheibe	Washer

Scheinwerfer verstellbar
Spotlight adjustable

286-6213

Seite/Page 3 / 3