

Hubwerk 1 Hoist 1

Hubwerk 2 Hoist 2

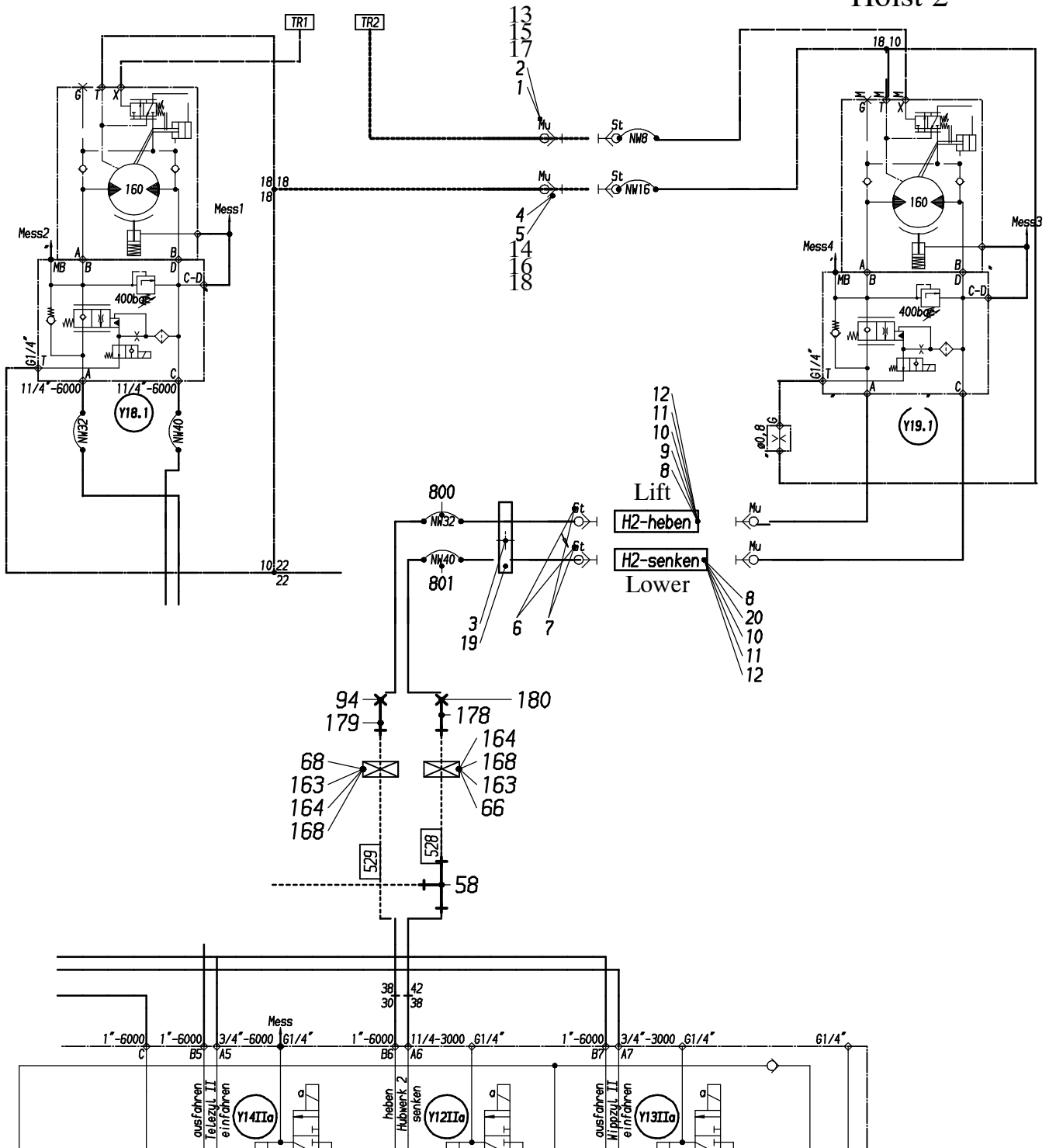

Steuerblock Controlblock

39-1865

Bild-Nr Fig Fig Fig Fig Bild nr	ET-Nr Part-No No. de Piece No. de Pieza No. del Pezzo Detalj nr	Stückzahl Qty Qte Ctd Qta Antal		Gegenstand Description Designation Descripcion Designazione Benaemning
01	551 586 40	1	Kupplungsmuffe	Coupling sleeve
02	551 588 40	1	Verschlußmutter	Plug
03	341 271 99	1	Karabinerhaken	Trigger snap
04	567 075 40	1	Kupplungsmuffe	Coupling sleeve
05	551 596 40	1	Verschlußmutter	Plug
06	490 799 40	2	Verschlußmutter	Plug
07	635 404 40	2	Kupplungsstecker	Coupler plug
08	253 577 40	2	Schild	Plate
09	007 625 98	1	Schelle	Clamp
10	307 445 99	2	Schraube	Bolt
11	346 500 99	2	Federring	Lock washer
12	332 333 99	2	Mutter	Nut
13	371 273 99	2	Überwurfmutter	Union nut
14	371 276 99	2	Überwurfmutter	Union nut
15	159 966 40	2	Klemmring	Clamping ring
16	180 055 40	2	Klemmring	Clamping ring
17	501 539 98	2	Hülse 10/6	Sleeve
18	501 541 98	2	Hülse 18/14	Sleeve
19	472 504 99	1	Kette	Chain
20	500 486 98	1	Schelle	Clamp
21	224 320 99	1	Schraube	Bolt
22	346 499 99	1	Federring	Lock washer
23	332 206 99	1	Mutter	Nut
58	509 548 99	2	Stutzen	Socket
66	502 201 98	1	Schelle	Clamp
68	534 019 99	3	Schelle	Clamp
94	371 869 99	1	Butzen	Breech block
163	511 858 98	5	Platte	Plate
164	504 030 98	14	Mutter	Nut
168	308 540 99	10	Schraube	Bolt
178	634 498 40	1	Stutzen	Socket
179	634 634 40	2	Stutzen	Socket
180	371 859 99	1	Butzen	Breech block
800	645 034 40	1	Schlauchleitung	Hose assy.
801	645 035 40	1	Schlauchleitung	Hose assy.
802	418 122 40	1	Schlauchleitung	Hose assy.