

00

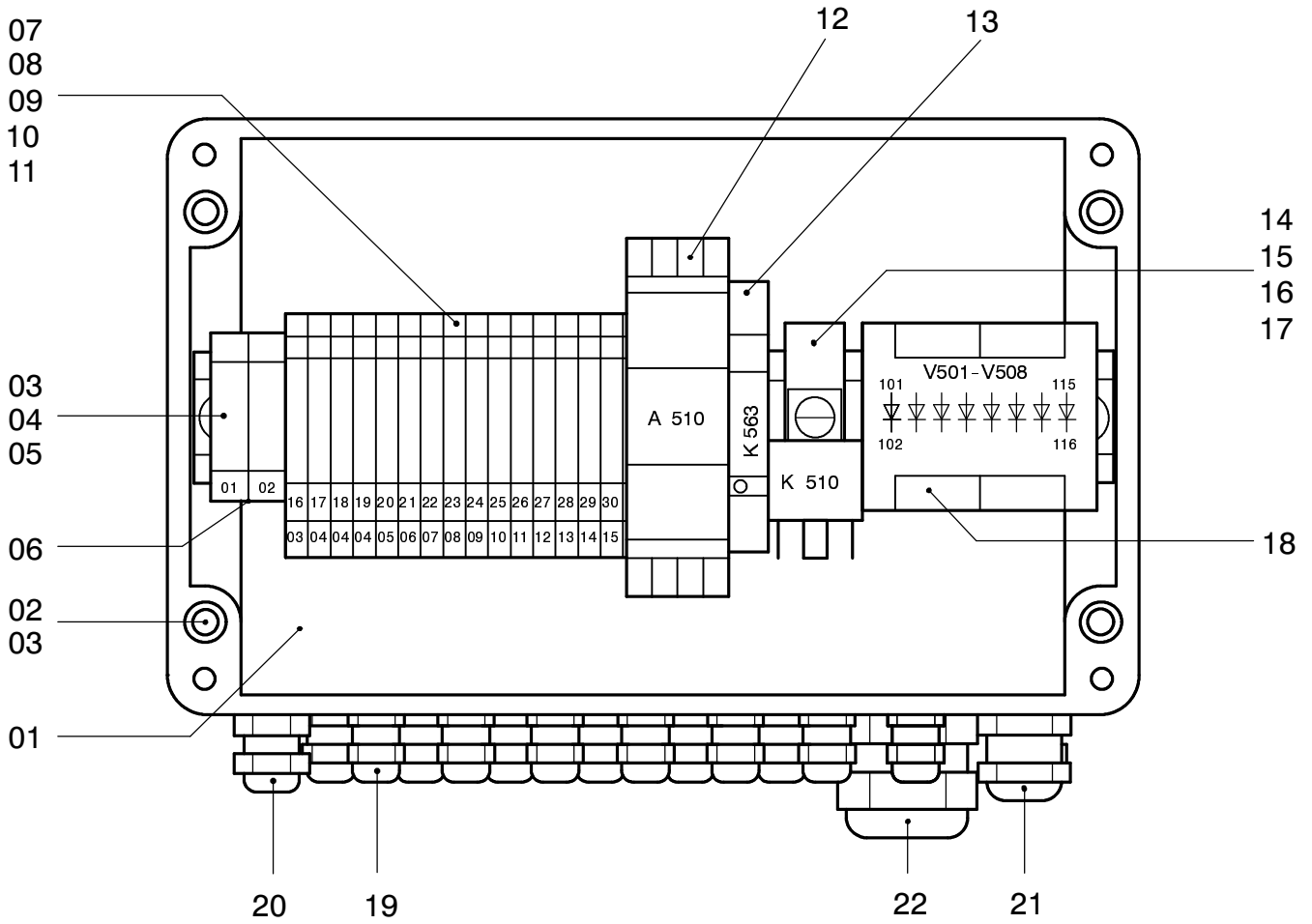

39-2232

Seite/Page 1 / 2

Bild-Nr Fig Fig Fig Fig Bild nr	ET-Nr Part-No No. de Piece No. de Pieza No. del Pezzo Detalj nr	Stückzahl Qty Qte Ctd Qta Antal		Gegenstand Description Designation Descripcion Designazione Benaeming
00	644 501 40	1	Verteilerkasten, kpl.	Distribution box assy.
01	270 312 40	1	Leergehäuse	Housing, emty
02	321 015 99	3	Zyl.-Schraube	Screw
03	346 499 99	5	Federring	Lock washer
04	505 954 99	1	Tragschiene, Länge angeben	Assembly rail, state length required
05	320 819 99	2	Zyl.-Schraube	Screw
06	356 274 40	2	Reihenklemme	Series terminal
07	356 264 40	15	Doppelstockklemme	Twin terminal
08	356 266 40	1	Abschlußplatte	Cover plate
09	356 268 40	1	Querverbinder	Cross connection
10	356 281 40	1	Bezeichnungskarte 1-10	Marker 1-10
11	356 282 40	2	Bezeichnungskarte 11-20	Marker 11-20
12	551 518 40	1	Logikbaustein	Logic element
13	551 005 40	1	Relaiskopple	Coupling relais
14	180 221 40	1	Schaltrelais 24V 10/20A	Switching relay
15	340 463 99	1	Scheibe	Washer
16	320 816 99	1	Zyl.-Schraube	Screw
17	324 068 40	1	Tragsockel	Supporting trestle
18	306 983 40	1	Diodengatter	Diode array
19	323 693 40	19	Kabelverschraubung	Cable union
20	300 970 40	2	Kabelverschraubung	Cable union
21	300 985 40	1	Kabelverschraubung	Cable union
22	270 250 40	1	Kabelverschraubung	Cable union

Verteilerkasten X510
Distribution Box

39-2232

Seite/Page 2 / 2