

39-6165

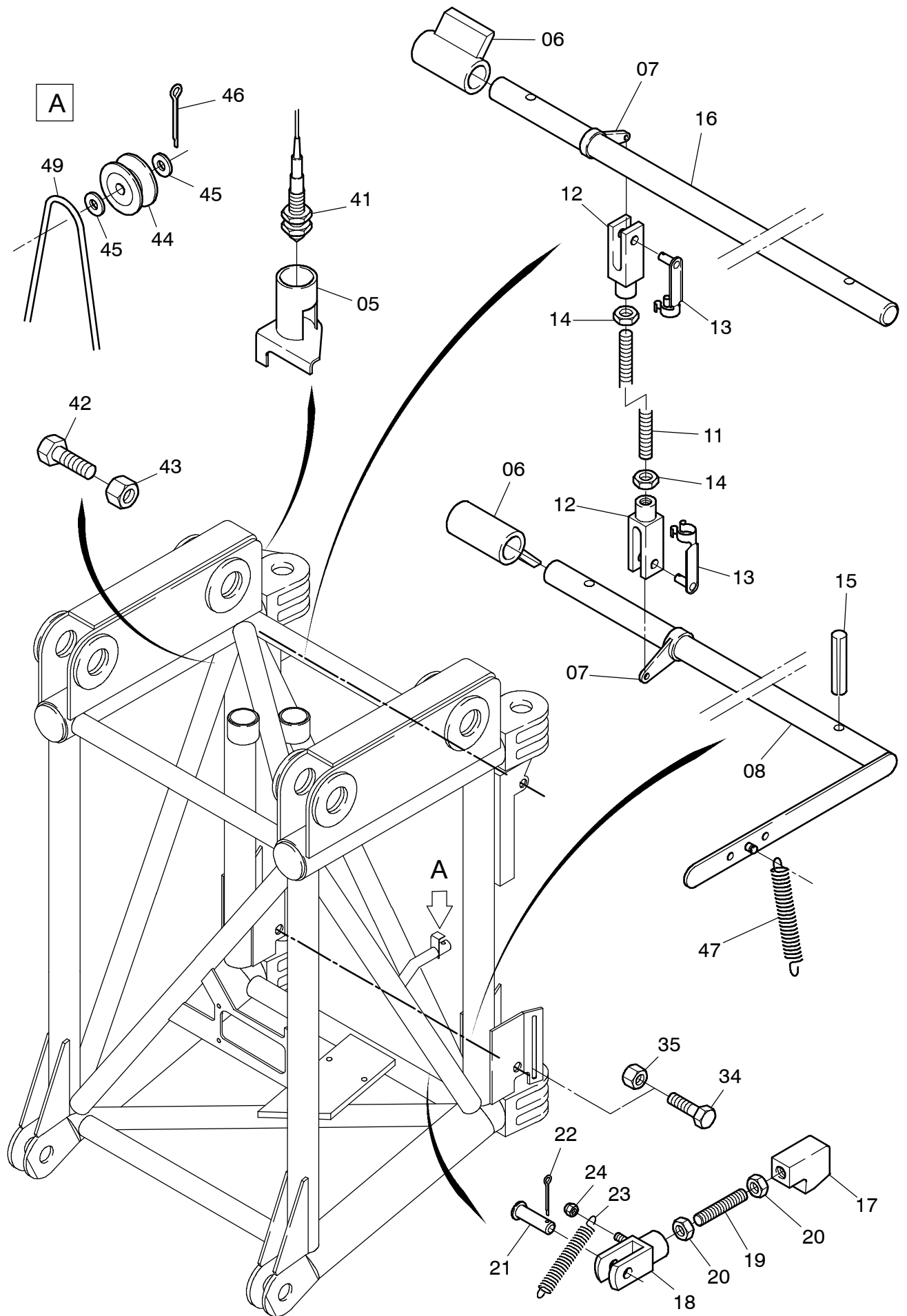

39-6165

Seite/Page 2 / 4

Bild-Nr Fig Fig Fig Fig Bild nr	ET-Nr Part-No No. de Piece No. de Pieza No. del Pezzo Detalj nr	Stückzahl Qty Qte Ctd Qta Antal		Gegenstand Description Designation Descripcion Designazione Benaemning
00	639 907 40	1	Adapter, kpl.	Adapter assy.
01	648 507 40	1	Adapter SK	Adapter
02	648 964 40	1	Halter, rechts	Retainer, r.h.
03	648 962 40	1	Halter, links	Retainer, l.h.
04	648 967 40	2	Zugstange	Draw bar
05	648 971 40	1	Halter für Initiator (oben)	Retainer for proximity switch (top)
-	648 937 40	1	Halter für Initiator (unten)	Retainer for proximity switch (lower)
06	648 973 40	4	Schnapper	Catch
07	648 976 40	2	Hebel	Lever
08	648 977 40	1	Stange	Rod
09	-	1	Hydraulikanlage HAV-Adapter s. EL-Blatt 39-6167	Hydr. system - adapter for main boom extension see page 39-6167
11	648 981 40	1	Gewindestange	Threaded rod
12	350 737 99	2	Gabelkopf	Fork end
13	002 830 98	2	Bolzen	Pin
14	332 334 99	2	Mutter	Nut
15	345 054 99	4	Spannstift	Dowel pin
16	648 978 40	1	Stange	Rod
17	648 983 40	1	Haken	Hook
18	648 982 40	1	Gabelkopf	Fork end
19	324 528 99	1	Gewindestift	Threaded pin
20	333 116 99	2	Mutter	Nut
21	648 984 40	1	Bolzen	Pin
22	342 049 99	1	Splint	Cotter pin
23	635 660 40	1	Zugfeder	Draw spring
24	320 068 99	2	Mutter	Nut
25	461 266 40	4	Bolzensicherung	Pin lock
26	648 985 40	4	Bolzen	Pin
27	664 443 40	4	Bolzen	Pin
28	665 882 40	4	Bolzensicherung best. aus Bild-Nr. 61+62	Pin lock consist. of fig-nos: 61+62
29	648 986 40	2	Bolzen	Pin
30	678 481 40	1	Bolzen	Pin
31	648 988 40	2	Bolzen	Pin
32	678 480 40	1	Bolzen	Pin
33	343 386 99	6	Nutmutter	Groove nut
34	504 628 98	3	Schraube	Bolt
35	332 353 99	3	Mutter	Nut

**Adapter für Hauptauslegerverlängerung
Adapter for Main Boom Extension**

39-6165

Seite/Page 3 / 4

Bild-Nr Fig Fig Fig Bild nr	ET-Nr Part-No No. de Piece No. de Pieza No. del Pezzo Detalj nr	Stückzahl Qty Qte Ctd Qta Antal		Gegenstand Description Designation Descripcion Designazione Benaemning
36	-	3	Lenkzylinder s. EL-Blatt 90-1266	Steering cylinder see page 90-1266
37	580 127 40	3	Ring	Ring
38	325 369 99	6	Gewindestift	Threaded pin
39	307 601 99	10	Schraube	Bolt
40	340 468 99	10	Scheibe	Washer
41	515 888 40	2	Näherungsschalter	Switch
42	500 621 98	1	Schraube	Bolt
43	332 355 99	1	Mutter	Nut
44	435 047 40	1	Seilrolle	Sheave
45	340 470 99	2	Scheibe	Washer
46	342 083 99	1	Splint	Cotter pin
47	648 991 40	1	Zugfeder	Draw spring
49	442 390 40	1	Seil	Rope
50	639 504 40	2	Schild Ziffer 4	Label cipher 4
51	639 502 40	1	Schild Ziffer 2	Label cipher 2
52	307 402 99	6	Schraube	Bolt
61	665 883 40	1	Hülse	Sleeve
62	665 884 40	1	Sicherungsfeder	Locking spring
71	-	1	Verteilerkasten X564 s. EL-Blatt 39-2282	Distribution box see page 39-2282
72	-	1	Hängetaster s. EL-Blatt 179-2166	Hanging key button see page 179-2166
73	515 210 40	4	Kabel 5 m lang	Cable

Adapter für Hauptauslegerverlängerung
Adapter for Main Boom Extension

39-6165

Seite/Page 4 / 4