

**Motor links
Engine left**

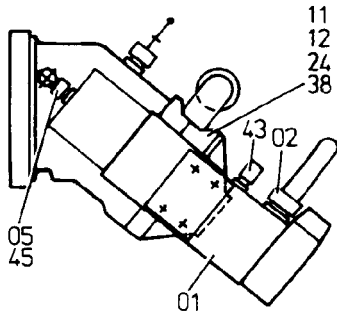

**Motor rechts
Engine right**

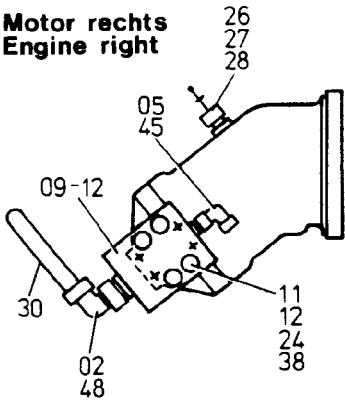

**Hubwerk II
Hoist II**

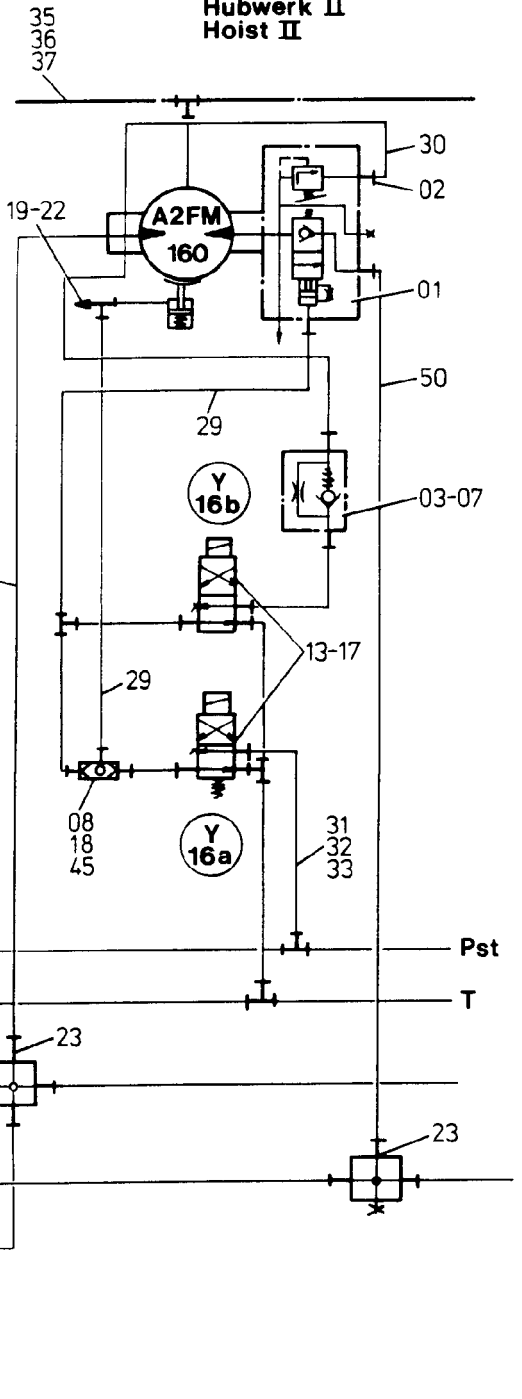

**Hubwerk I
Hoist I**

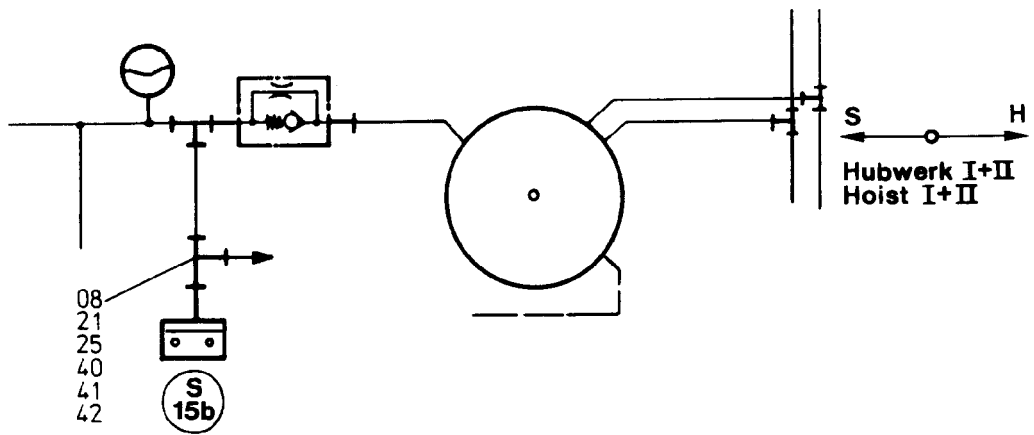
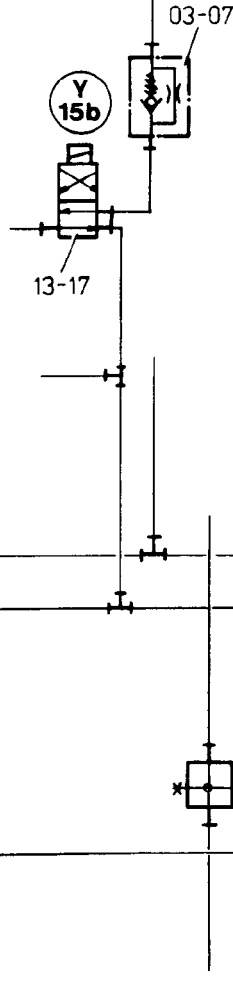

40-1870b

Bild-Nr Fig Fig Fig Fig Bild nr	ET-Nr Part-No No. de Piece No. de Pieza No. del Pezzo Detailj nr	Stückzahl Qty Qte Ctd Qta Antal		Gegenstand Description Designation Descripcion Designazione Benaemning
01	255 636 40	1	Sperr-Q-Meter	Check-q-meter
02	372 452 99	2	Verschraubung	Union
03	515 901 40	2	Drosselrückschlagventil	Throttle check valve
04	270 825 40	2	Düse	Nozzle
05	371 452 99	3	Verschraubung	Union
06	502 000 98	2	Verschraubung	Union
07	372 895 99	2	Verschraubung	Union
08	371 953 99	6	Verschraubung	Union
09	501 981 40	1	Zwischenplatte	Intermediate plate
10	319 483 99	4	Schraube	Bolt
11	343 866 99	12	Federring	Lock washer
12	006 725 98	3	O-Ring	O-ring
13	226 959 40	3	4/2 Magnetventil	4/2 Solenoid valve
14	180 325 40	3	Grundplatte	Base plate
15	319 174 99	12	Schraube	Bolt
16	255 694 40	3	Verschlußstopfen	Plug
17	370 313 99	9	Verschraubung	Union
18	256 977 40	1	Wechselventil	Shuttle valve
19	372 432 99	1	Verschraubung	Union
20	373 010 99	1	Verschraubung	Union
21	502 752 98	2	Meßstutzen	Test socket
22	418 331 40	1	Rohr ø 6	Pipe
23	180 065 40	2	Flanschverbindung	Flange connection
24	006 638 98	4	Flanschhälfte	Half flange
25	373 003 99	1	Verschraubung	Union
26	502 437 98	1	Verschraubung	Union
27	372 910 99	1	Verschraubung	Union
28	372 616 99	1	Verschraubung	Union
29	*	-	Rohr ø 12	Pipe
30	*	-	Rohr ø 22	Pipe
31	*	-	Kunststoffrohr ø 12	Plastic Pipe
32	137 296 40	20	Einsteckhülse	Plug-in sleeve
33	159 965 40	20	Klemmring	Clamping ring
35	*	-	Kunststoffrohr ø 22	Plastic pipe
36	007 580 98	4	Einsteckhülse	Plug-in sleeve
37	180 056 40	4	Klemmring	Clamping ring
38	319 209 99	8	Schraube	Bolt
40	320 214 99	6	Schraube	Bolt
41	332 110 99	6	Mutter	Nut
42	504 014 98	6	Federring	Lock washer
43	153 646 40	1	Minimeßkupplung	Test coupling

Bild-Nr Fig Fig Fig Fig Bild nr	ET-Nr Part-No No. de Piece No. de Pieza No. del Pezzo Detailj nr	Stückzahl Qty Qte Ctd Qta Antal		Gegenstand Description Designation Descripcion Designazione Benaemning
45	372 172 99	6	Verschraubung	Union
48	372 175 99	1	Verschraubung	Union
50	254 086 40	1	Schlauch NW32x1250	Hose
51	166 914 40	1	Schlauch NW32x1100	Hose
			* Meterware, bei Bestellung Länge angeben	* Bulk ware, state length required
*	215 642 99		Rohr ø 12	Pipe
*	215 495 99		Rohr ø 22	Pipe
*	211 301 99		Kunststoffrohr ø 12	Plastic Pipe
*	501 683 98		Kunststoffrohr ø 22	Plastic Pipe