

Motorstopmagnet und Halterung in Ansicht gezeichnet

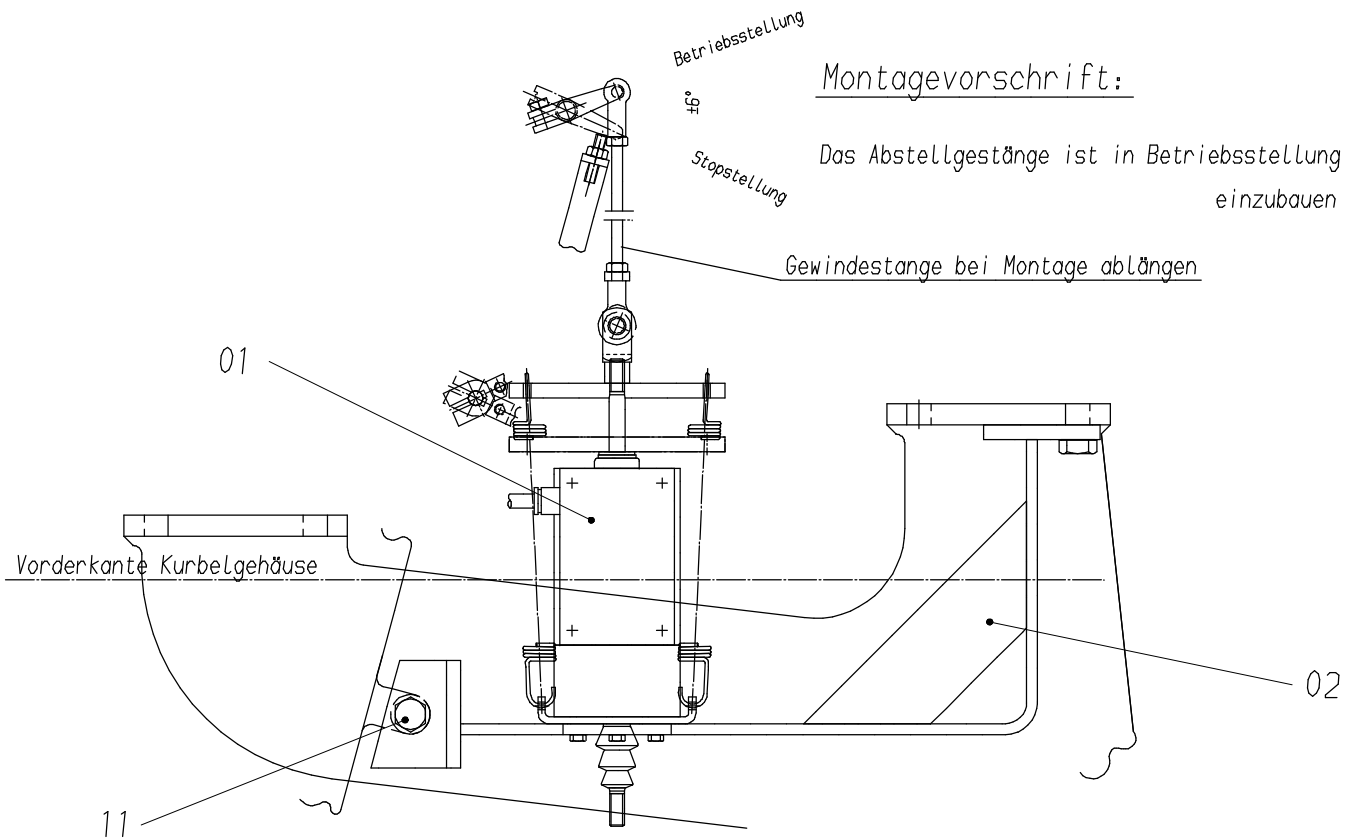

**52-1212a**

Seite/Page 1 / 2

<b>Bild-Nr</b> Fig Fig Fig Fig Bild nr	<b>ET-Nr</b> Part-No No. de Piece No. de Pieza No. del Pezzo Detalj nr	<b>Stückzahl</b> Qty Qte Ctd Qta Antal		<b>Gegenstand</b> Description Designation Descripcion Designazione Benaemning
00	677 674 40	1	Motorstop, kpl.	Engine-stop assy.
01	871 778 40	1	Motorstop	Engine-stop
02	677 673 40	1	Halter	Retainer
03	628 869 40	1	Gewindestange	Threaded rod
04	300 257 99	1	Winkelgeber	Angle transmitter
05	307 706 99	6	Schraube	Bolt
06	346 509 99	6	Federring	Lock washer
07	634 845 40	1	Gelenkkopf	Knuckle
08	002 824 98	1	Bolzen	Pin
09	320 068 99	3	Mutter	Nut
10	350 748 99	1	Gabelkopf	Fork end
11	308 577 99	1	Schraube	Bolt

**Motorstop  
Engine Stop**

**52-1212a**

Seite/Page 2 / 2