

52-6276b

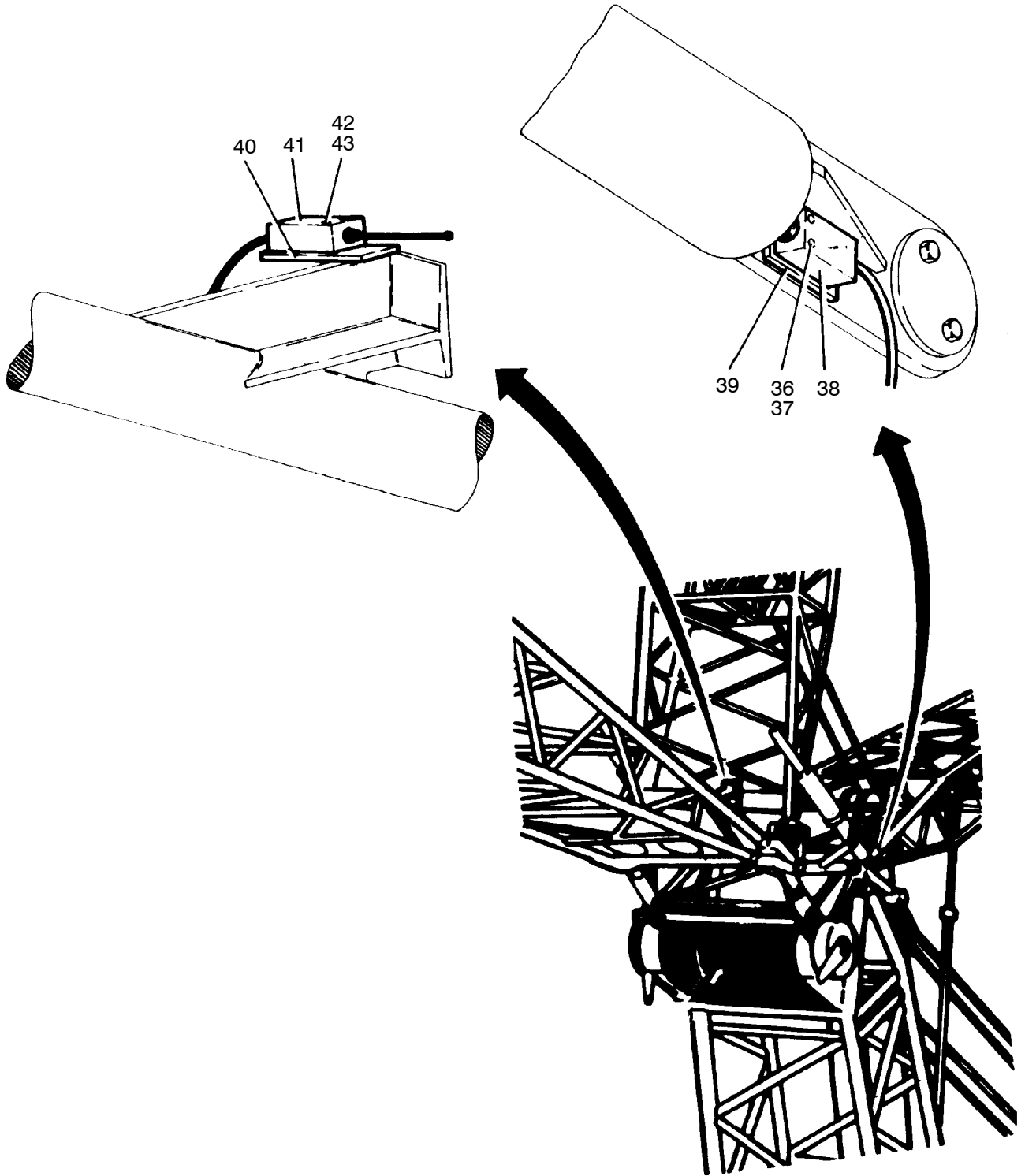

52-6276b

Bild-Nr Fig Fig Fig Fig Bild nr	ET-Nr Part-No No. de Piece No. de Pieza No. del Pezzo Detailj nr	Stückzahl Qty Qte Ctd Qta Antal	Gegenstand Description Designation Descripcion Designazione Benaemning	
01	269 598 40	1	Getriebe-Nocken-Endschalter	Gear camshaft controller
01	440 112 40	1	Getriebe-Nocken-Endschalter ab Bau Nr. 64 098	Gear camshaft controller
04	502 434 40	1	Halteblech	Holding plate
04	596 290 40	1	Halteblech ab Bau Nr. 64 098	Holding plate
05	372 508 40	1	Hebel	Lever
06	502 418 40	1	Blech (bei Montage anschweißen)	Plate (to be welded)
07	502 419 40	1	Halteblech (bei Montage anschweißen)	Holding plate (to be welded)
08	286 425 40	1	Bundschraube	Collar screw
09	502 409 40	1	Halteblech (bei Montage anschweißen)	Holding plate (to be welded)
10	502 408 40	1	Blech (bei Montage anschweißen)	Plate (to be welded)
11	307 779 99	1	Schraube	Bolt
12	307 332 99	2	Schraube	Bolt
14	320 315 99	3	Schraube	Bolt
15	332 114 99	2	Mutter	Nut
16	500 801 98	3	Scheibe	Disc
17	500 799 98	3	Scheibe	Disc
19	345 010 99	1	Spannstift	Dowel pin
30	595 918 40	1	Endschalteranbau Rückschlagschlagzylinder	End switches Back stroke cylinder
36	346 509 99	2	Federring	Lock washer
37	320 817 99	2	Schraube	Screw
38	167 676 40	1	Endschalter	End switch
39	240 305 40	1	Blech (bei Montage Anschweißen)	Plate (to be welded)
40	240 306 40	1	Blech (bei Montage Anschweißen)	Plate (to be welded)
41	167 677 40	1	Steuerschalter	Control switch
42	320 977 40	2	Schraube	Screw
43	346 508 99	2	Federring	Lock washer

**Endschalteranbau HI  
Limit Switch Arr.**

**52-6276b**

Seite/Page 3/3