

58-3120

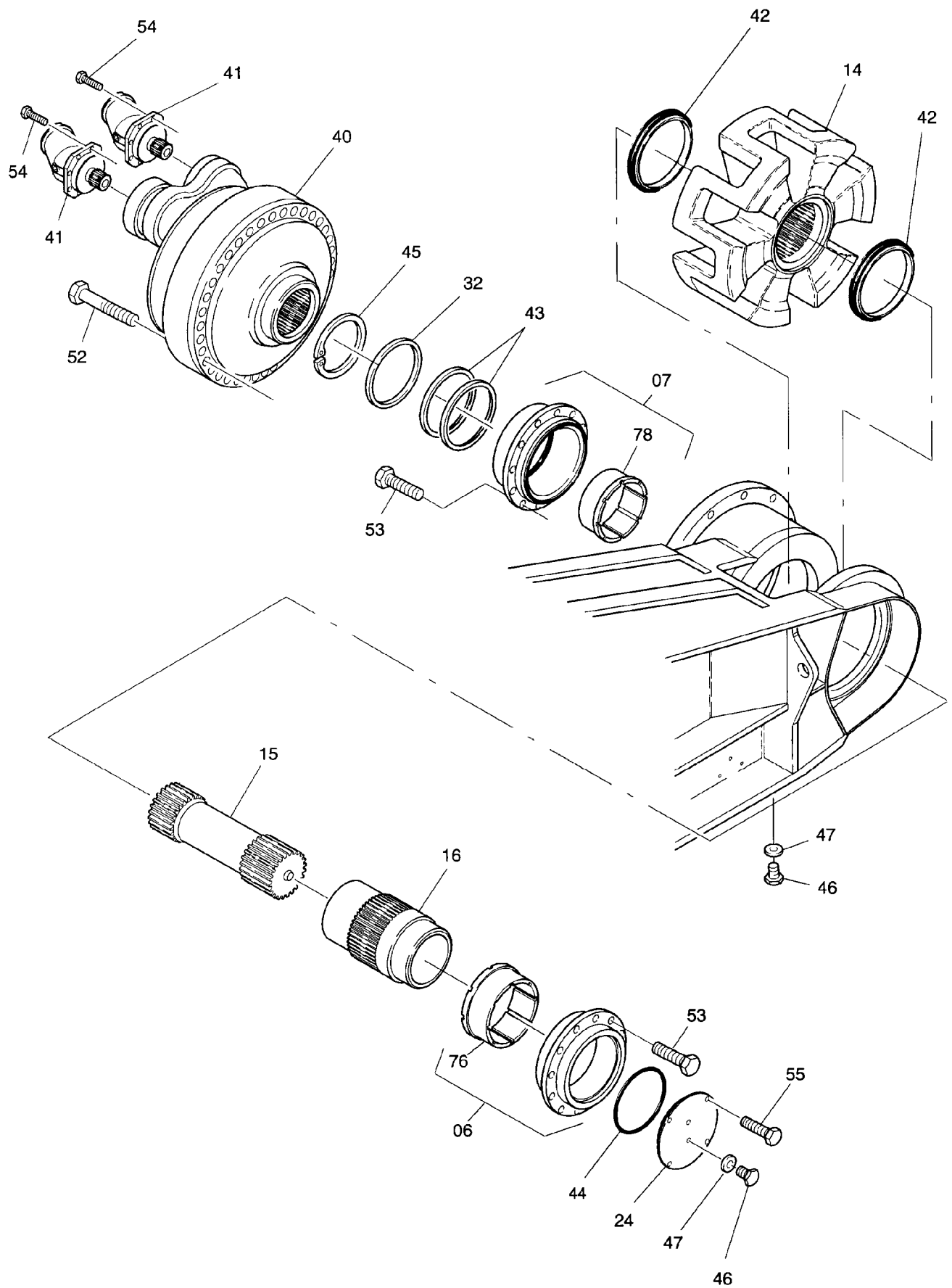

58-3120

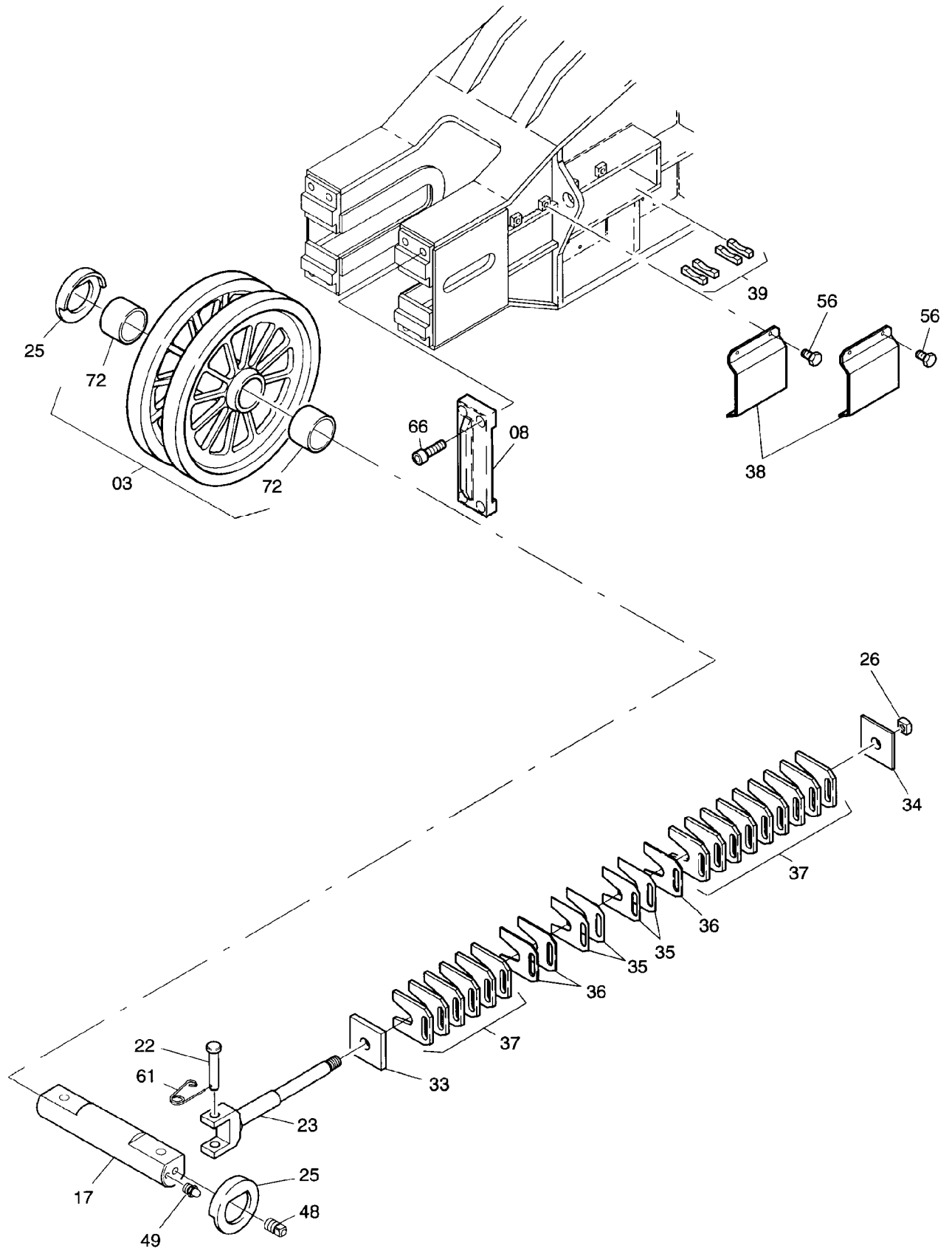

58-3120

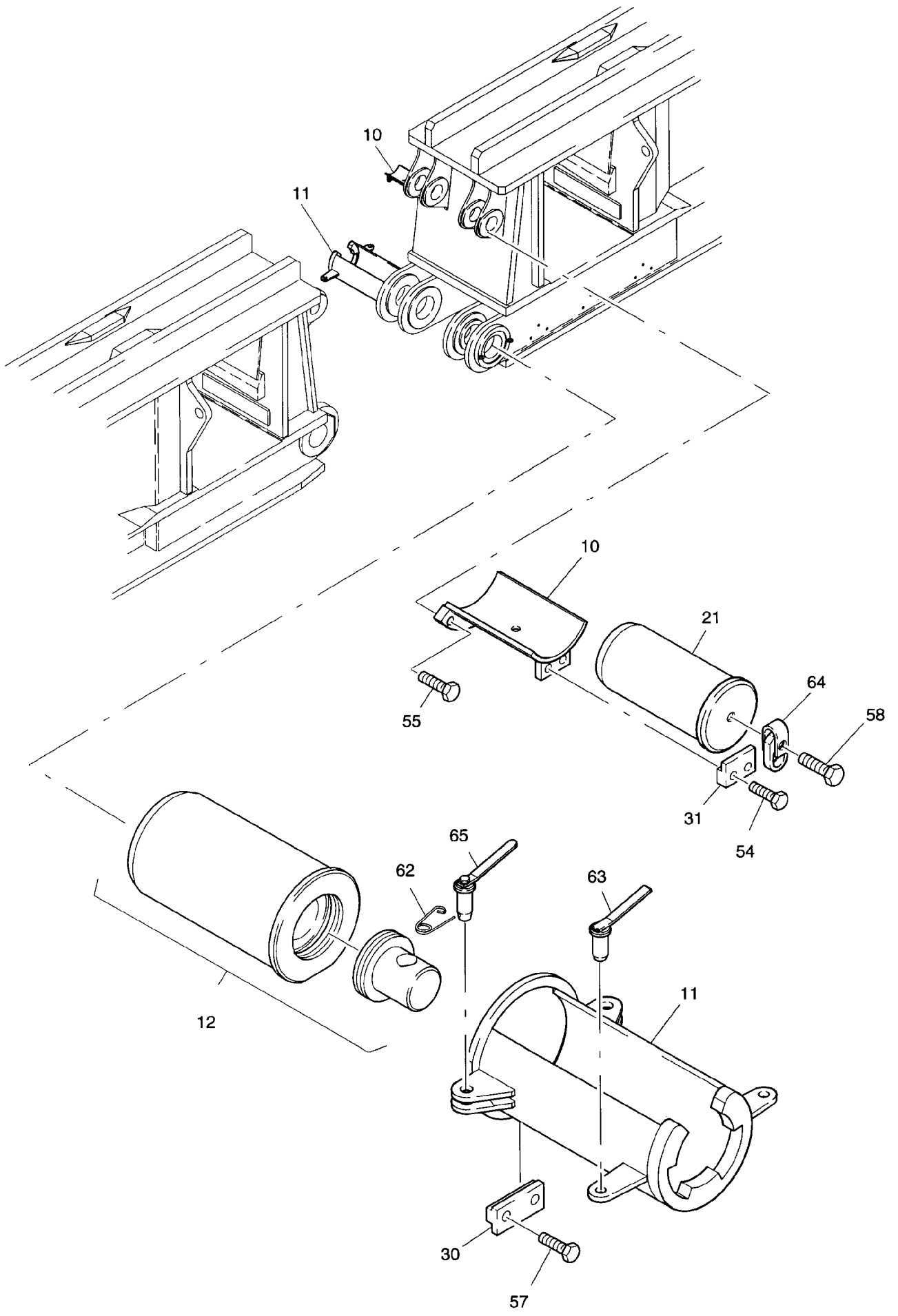

58-3120

Bild-Nr Fig Fig Fig Fig Bild nr	ET-Nr Part-No No. de Piece No. de Pieza No. del Pezzo Detailj nr	Stückzahl Qty Qte Ctd Qta Antal		Gegenstand Description Designation Descripcion Designazione Benaemning
00	577 981 40	1	Raupenträger links kpl. geteilt	Track frame l.h. assy. split
01	577 603 40	1	Raupenträger links SK Turasseite	Track frame l.h. (weldment) drive sprocket side
02	577 601 40	1	Raupenträger links SK Leitradseite	Track frame l.h. (weldment) idler protection
03	262 625 40	1	Leitrad kpl.	Idler assy.
04	577 819 40	18	Laufrolle kpl.	Bottom roller
05	577 827 40	2	Tragrolle kpl.	Top roller
06	438 547 40	1	Flanschlager außen	Flange bearing outer
07	438 548 40	1	Flanschlager innen	Flange bearing inner
08	577 890 40	2	Endanschlag	Limiter
09	598 021 40	2	Rollenbock kpl.	Sheave block assy.
10	577 899 40	2	Bolzenablage oben	Pin rest, top
11	597 984 40	2	Bolzenablage unten	Pin rest, bottom
12	577 896 40	2	Bolzen kpl.	Pin assy.
13	577 824 40	88	Bodenplatte	Track shoe
14	424 711 40	1	Turas	Drive sprocket
15	577 816 40	1	Antriebswelle	Drive shaft
16	424 894 40	1	Hohlwelle	Sleeve shaft
17	577 823 40	1	Achse	Axle
18	577 833 40	18	Achse	Axle
19	577 832 40	2	Achse	Axle
20	261 166 40	176	Bolzen	Pin
21	577 894 40	2	Bolzen	Pin
22	566 342 40	2	Bolzen	Pin
23	577 825 40	2	Gabelstange	Fork rod
24	424 899 40	1	Deckel	Cover
25	262 669 40	2	Abstreifer	Scraper
26	577 826 40	2	Mutter	Nut
27	603 732 40	36	Scheibe	Disc
28	577 835 40	4	Scheibe	Disc
29	577 834 40	4	Achshalter	Axle stirrup
30	577 897 40	2	Bolzensicherung	Pin lock
31	577 898 40	2	Bolzensicherung	Pin lock
32	424 837 40	1	Ring	Ring
33	577 839 40	2	Platte	Plate
34	577 840 40	2	Platte	Plate
35	577 838 40	8	Platte	Plate
36	577 837 40	6	Platte	Plate
37	577 836 40	30	Platte	Plate
38	577 841 40	4	Deckblech	Cover plate

**Raupenträger, links  
Track Frame, L.H.**

**58-3120**

Seite/Page 5/7

Bild-Nr Fig Fig Fig Fig Bild nr	ET-Nr Part-No No. de Piece No. de Pieza No. del Pezzo Detailj nr	Stückzahl Qty Qte Ctd Qta Antal		Gegenstand Description Designation Descripcion Designazione Benaemning
39	577 893 40	8	Blech	Plate
40	-	1	Fahrgetriebe s. EL-Blatt 90-2858	Drive gear box see page 90-2858
41	-	2	Konstantmotor A2FM s. EL-Blatt 90-2859	Fixed displacement motor see page 90-2859
42	358 614 40	2	Gleitringdichtung	Lifetime seal
43	505 418 98	2	Dichtring	Seal ring
44	505 419 98	1	O-Ring	O-ring
45	505 417 98	1	Sicherungsring	Circlip
46	349 988 99	4	Verschlussschraube	Plug
47	339 907 99	4	Dichtring	Seal ring
48	370 834 99	19	Stopfen	Plug
49	004 860 98	21	Schmiernippel	Grease nipple
50	510 423 98	176	Schraube	Bolt
51	510 424 98	176	Mutter	Nut
52	510 607 98	36	Schraube	Bolt
53	308 389 99	24	Schraube	Bolt
54	308 631 99	20	Schraube	Bolt
55	307 581 99	16	Schraube	Bolt
56	307 804 99	8	Schraube	Bolt
57	307 615 99	4	Schraube	Bolt
58	308 665 99	2	Schraube	Bolt
59	500 333 98	20	Schraube	Bolt
60	507 743 98	12	Scheibe	Disc
61	001 645 98	2	Sicherungsfeder	Locking spring
62	001 644 98	4	Sicherungsfeder	Locking spring
63	490 505 40	2	Sicherungsbolzen	Lock pin
64	551 614 40	2	Lastbock	Load bloc
65	577 968 40	4	Bolzen mit Griff	Pin with handle
66	319 361 99	8	Schraube	Bolt
72	320 773 40	2	Buchse	Bushing
73	307 424 40	36	Buchse	Bushing
74	577 831 40	4	Buchse	Bushing
76	424 898 40	1	Buchse	Bushing
78	424 898 40	1	Buchse	Bushing
81	598 022 40	2	Rollenbock, SK	Sheave block (weldment)
82	598 033 40	4	Rolle kpl.	Roller assy.
83	598 031 40	4	Deckel	Cover
84	598 032 40	8	Scheibe	Disc
85	598 030 40	4	Achse	Axle
86	598 036 40	4	Deckel	Cover
87	319 271 99	32	Schraube	Bolt

**Raupenträger, links**  
**Track Frame, L.H.**

**58-3120**

Seite/Page 6/7

Bild-Nr Fig Fig Fig Fig Bild nr	ET-Nr Part-No No. de Piece No. de Pieza No. del Pezzo Detailj nr	Stückzahl Qty Qte Ctd Qta Antal		Gegenstand Description Designation Descripcion Designazione Benaemning
88	350 562 99	4	Schmiernippel	Grease nipple
<b>Raupenträger, links</b> <b>Track Frame, L.H.</b>				<b>58-3120</b> Seite/Page 7/7