

59-1422a

Seite/Page 1 / 5

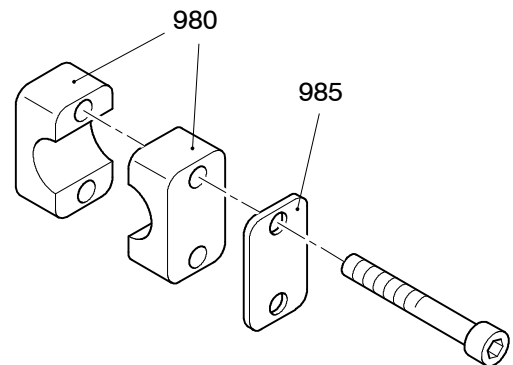
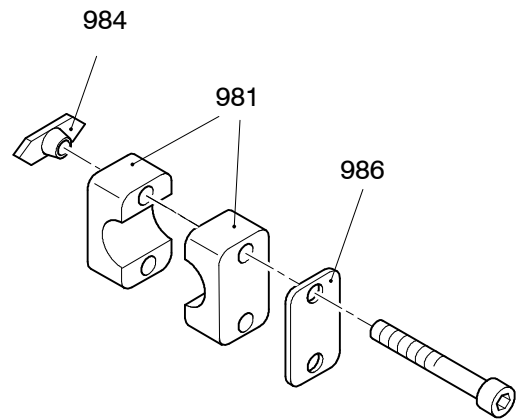
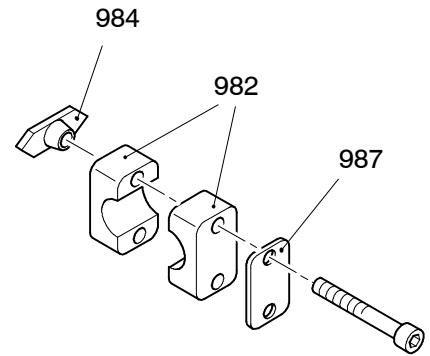
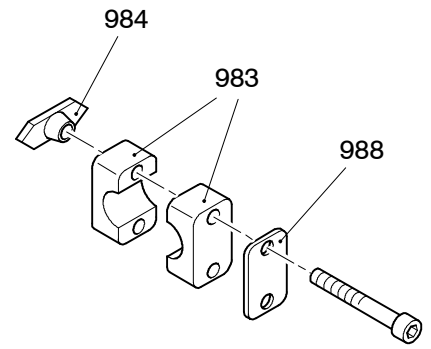
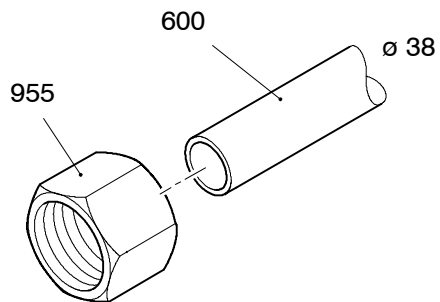
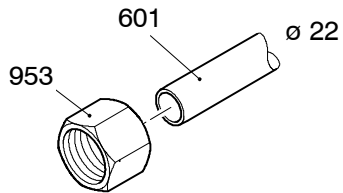
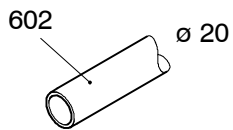
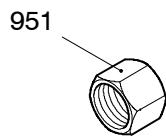
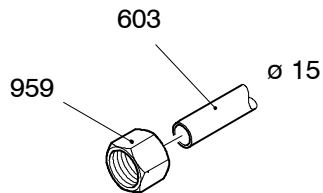
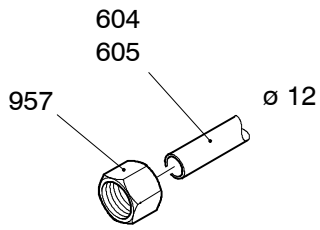

59-1422a

Seite/Page 2 / 5

Bild-Nr Fig Fig Fig Fig Bild nr	ET-Nr Part-No No. de Piece No. de Pieza No. del Pezzo Detalj nr	Stückzahl Qty Qte Ctd Qta Antal		Gegenstand Description Designation Descrpcion Designazione Benaemning
01	002 005 12	1	Senkbremsventil	Lowering brake valve
02	000 558 12	1	SAE-Adapter	Adapter
03	889 087 40	1	Steuerblock	Control block
04	001 468 12	1	Druckbegrenzungsventil	Pressure relief valve
05	634 360 40	1	Rückschlagventil	Non-return valve
06	001 579 12	1	Druckaufnehmer	Pressure transducer
07	132 330 12	1	Halter	Retainer
08	210 906 40	1	Sperrventil	Check valve
09	419 279 40	1	Düsenträger	Nozzle holder
10	621 047 40	1	Düse	Nossle
200	592 576 40	1	O-Ring	O-ring
201	021 858 12	1	Rohrverteiler	
202	654 921 40	1	Flanschverbindung	Flange connection
300	635 404 40	2	Kupplungsstecker	Coupler plug
301	490 799 40	2	Verschlußschraube	Screw plug
302	634 111 40	1	Kupplungsstecker	Coupler plug
303	551 597 40	1	Verschlußschraube	Screw plug
304	551 591 40	1	Kupplungsstecker	Coupler plug
305	551 593 40	1	Verschlußschraube	Screw plug
306	567 072 40	1	Kupplungsstecker	Coupler plug
307	551 589 40	1	Verschlußschraube	Screw plug
400	319 485 99	4	Schraube	Bolt
401	319 139 99	2	Schraube	Screw
402	343 854 99	2	Federring	Lock washer
600	506 367 98	-	Rohr ø 38 - Länge angeben	Pipe ø 38 - state length required
601	215 495 99	-	Rohr ø 22 - Länge angeben	Pipe ø 22 - state length required
602	215 219 99	-	Rohr ø 20 - Länge angeben	Pipe ø 20 - state length required
603	215 811 99	-	Rohr ø 15 - Länge angeben	Pipe ø 15 - state length required
604	215 642 99	-	Rohr ø 12x2 - Länge angeben	Pipe ø 12x2 - state length required
605	215 424 99	-	Rohr ø 12x1,5 - Länge angeben	Pipe ø 12x1,5 - state length required
800	130 814 12	1	Schlauchleitung	Hose assy.
801	130 816 12	1	Schlauchleitung	Hose assy.
802	132 323 12	1	Schlauchleitung	Hose assy.
803	130 817 12	1	Schlauchleitung	Hose assy.

Bild-Nr Fig Fig Fig Fig Bild nr	ET-Nr Part-No No. de Piece No. de Pieza No. del Pezzo Detalj nr	Stückzahl Qty Qte Ctd Qta Antal		Gegenstand Description Designation Descripcion Designazione Benaemning
804	132 322 12	1	Schlauchleitung	Hose assy.
805	306 928 40	1	Schlauchleitung	Hose assy.
806	132 327 12	1	Schlauchleitung	Hose assy.
901	621 771 40	1	Stutzen	Socket
904	000 482 12	1	Stutzen	Socket
905	551 404 40	1	Stutzen	Socket
906	576 469 40	1	Stutzen	Socket
907	551 483 40	1	Stutzen	Socket
908	634 393 40	1	Stutzen	Socket
909	006 525 98	2	Stutzen	Socket
910	502 752 98	1	Stutzen	Socket
911	592 135 40	4	Stutzen	Socket
912	621 793 40	2	Stutzen	Socket
913	255 694 40	1	Verschlussschraube	Screw plug
914	576 442 40	1	Stutzen	Socket
915	576 438 40	2	Stutzen	Socket
916	551 958 40	4	Stutzen	Socket
917	551 480 40	2	Stutzen	Socket
918	621 796 40	2	Stutzen	Socket
919	621 125 40	1	Stutzen	Socket
920	004 396 98	1	Stutzen	Socket
950	371 243 99	2	Schneidring	Olive
951	371 276 99	2	Überwurfmutter	Union nut
952	371 244 99	2	Schneidring	Olive
953	510 017 98	2	Überwurfmutter	Union nut
954	371 237 99	2	Schneidring	Olive
955	371 266 99	2	Überwurfmutter	Union nut
956	371 241 99	8	Schneidring	Olive
957	509 809 98	8	Überwurfmutter	Union nut
958	371 242 99	1	Schneidring	Olive
959	371 275 99	1	Überwurfmutter	Union nut
970	253 577 40	10	Schild	Label
971	472 687 99	-	Kette - Länge angeben	Chain - state length required
972	243 420 40	10	Schlüsselring	Ring
980	504 093 98	10	Klemmhälftenpaar	Pair of half clamps
981	501 598 98	2	Klemmhälftenpaar	Pair of half clamps
982	504 780 98	2	Klemmhälftenpaar	Pair of half clamps
983	502 170 99	2	Klemmhälftenpaar	Pair of half clamps
984	504 030 98	12	Tragschienenmutter	Rail nut
985	505 712 98	4	Druckplatte	Pressure plate
986	511 857 98	2	Druckplatte	Pressure plate

Hydr. zum Hubwerk III
Hydr. at Hoist Gear III

59-1422a

Seite/Page 4 / 5

Bild-Nr Fig Fig Fig Fig Bild nr	ET-Nr Part-No No. de Piece No. de Pieza No. del Pezzo Detalj nr	Stückzahl Qty Qte Ctd Qta Antal		Gegenstand Description Designation Descripcion Designazione Benaemning
987	511 856 98	2	Druckplatte	Pressure plate
988	511 855 98	2	Druckplatte	Pressure plate

Hydr. zum Hubwerk III
Hydr. at Hoist Gear III

59-1422a

Seite/Page 5 / 5