

Ansicht A

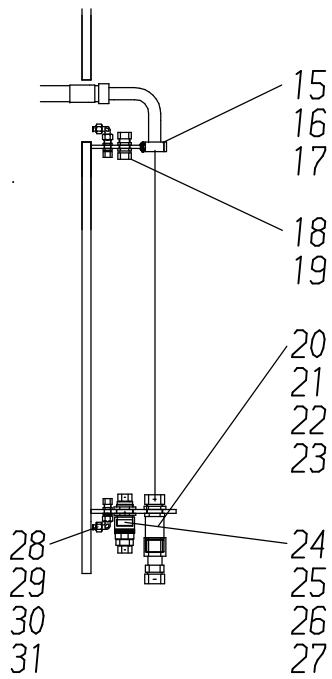

Ansicht B

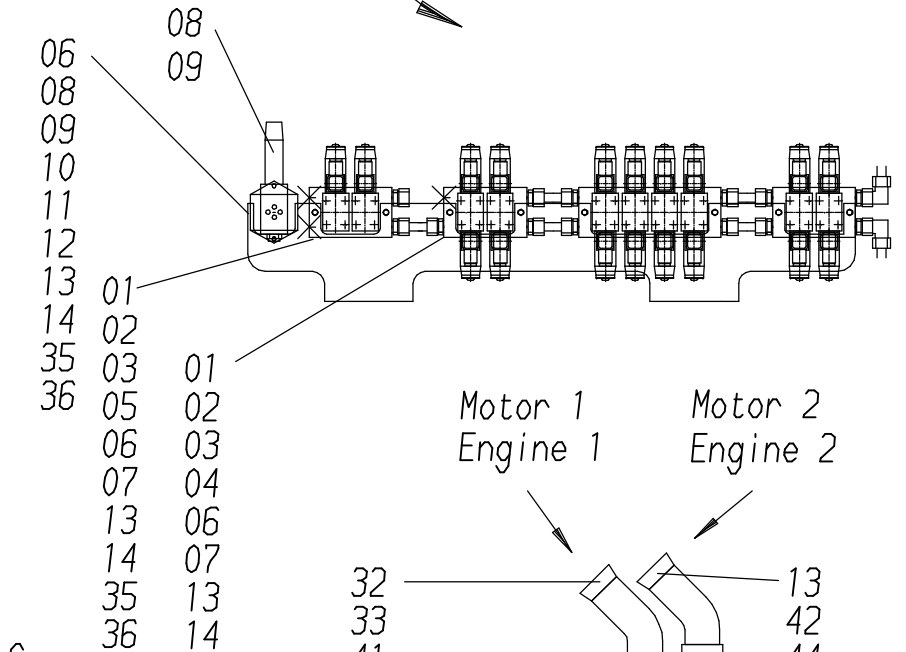
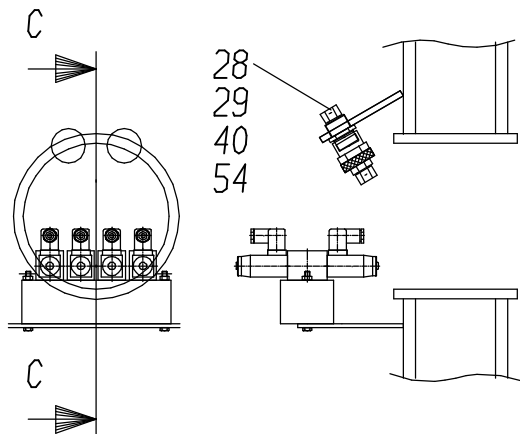

C

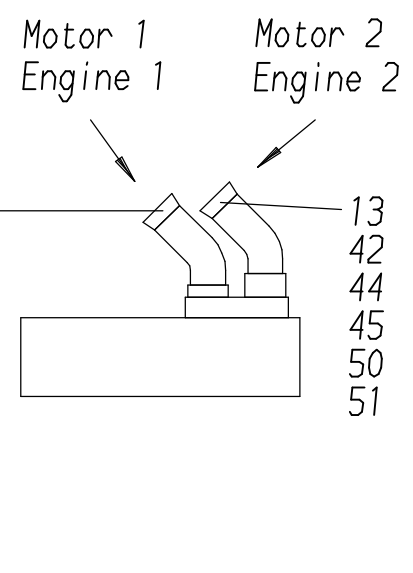

62-3140

Bild-Nr Fig Fig Fig Fig Bild nr	ET-Nr Part-No No. de Piece No. de Pieza No. del Pezzo Detalj nr	Stückzahl Qty Qte Ctd Qta Antal		Gegenstand Description Designation Descripcion Designazione Benaemning
00	889 591 40	1	Hydr. Anlage UW kpl.	Hydr. Chassis, assy.
01	635 205 40	2	Reihenflanschplatte	Manifold
02	308 563 99	4	Schraube	Bolt
03	332 111 99	4	Mutter	Nut
04	180 936 40	2	Magnetventil	Solenoid valve
05	226 959 40	2	4/2-Wege-Magnetventil	Directional spool valve
06	319 174 99	20	Schraube	Bolt
07	343 852 99	16	Federring	Lock washer
08	256 332 40	1	Druckreduzierventil	Reducing valve
09	180 325 40	1	Grundplatte	Base plate
10	307 408 99	2	Schraube	Bolt
11	332 110 99	2	Mutter	Nut
12	889 599 40	1	Symbolplatten	Symbol plate
13	621 793 40	18	Stutzen	Socket
14	255 694 40	4	Verschlußschraube	Plug
15	534 022 99	8	Klemmpaar	Pair of half clamps
16	534 004 99	4	Platte	Plate
17	308 581 99	8	Schraube	Bolt
18	509 592 98	2	Stutzen	Socket
19	509 591 98	8	Stutzen	Socket
20	000 576 12	4	Kupplungsmuffe NW32	Coupling sleeve
21	000 577 12	4	Verschlußmutter	Lock nut
22	000 578 12	4	Kupplungsstecker NW 32	Coupler plug
23	000 579 12	4	Verschlußschraube	Plug
24	551 594 40	2	Kupplungsmuffe	Coupling sleeve
25	551 596 40	2	Verschlußmutter	Lock nut
26	551 595 40	2	Kupplungsstecker NW20	Coupler plug
27	551 597 40	2	Verschlußschraube	Plug
28	551 590 40	6	Kupplungsmuffe NW12	Coupling sleeve
29	551 592 40	6	Verschlußmutter	Lock nut
30	551 591 40	4	Kupplungsstecker NW12	Coupler plug
31	551 593 40	4	Verschlußschraube	Plug
32	592 581 40	8	O-Ring	O-ring
33	006 639 98	16	Flanschkälfte	Half flange
34	502 330 98	16	Schraube	Bolt
35	551 449 40	2	Stutzen	Socket
36	006 525 98	2	Stutzen	Socket
40	551 442 40	1	Stutzen	Socket
41	000 639 12	2	Anschlußblock	Connection block
42	592 576 40	8	O-Ring	o-ring

**Hydr. Unterwagen
Hydr. Chassis**

62-3140

Seite/Page 2 / 3

Bild-Nr Fig Fig Fig Fig Bild nr	ET-Nr Part-No No. de Piece No. de Pieza No. del Pezzo Detalj nr	Stückzahl Qty Qte Ctd Qta Antal		Gegenstand Description Designation Descripcion Designazione Benaemning
43	321 611 99	16	Schraube	Bolt
44	343 866 99	32	Federring	Lock washer
45	576 418 40	8	Flanschverbindung	Flange connection
48	319 288 99	16	Schraube	Bolt
49	343 857 99	16	Federring	Lock washer
50	130 903 12	2	Umschaltsteuerblock	Change over control block
51	321 539 99	16	Schraube	Bolt
53	049 342 40	2	Druckbegrenzungsventil	Pressure relief valve
54	253 577 40	2	Schild	Lable

**Hydr. Unterwagen
Hydr. Chassis**

62-3140

Seite/Page 3 / 3