

**62-6024**

Seite/Page 1 / 4

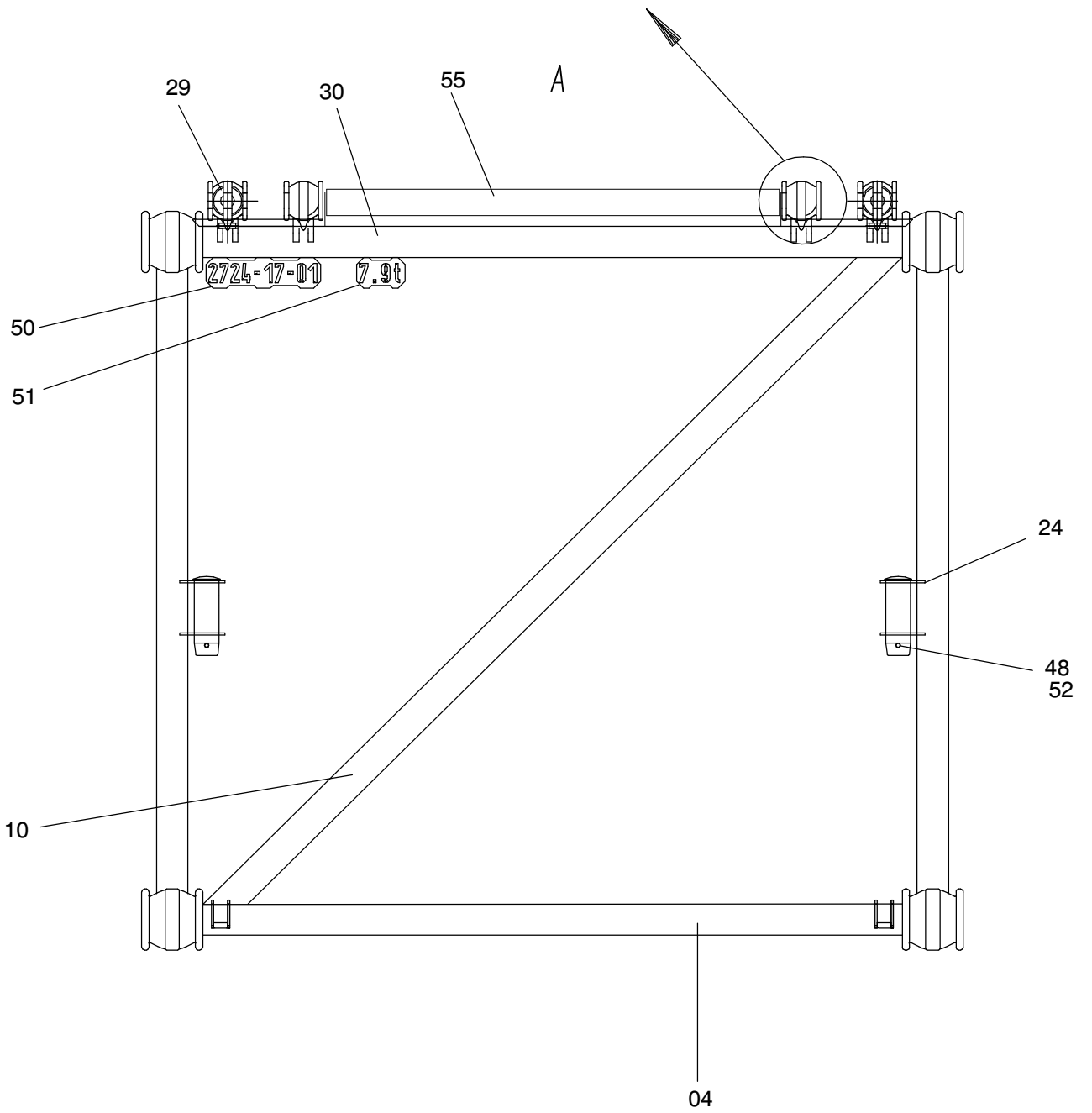
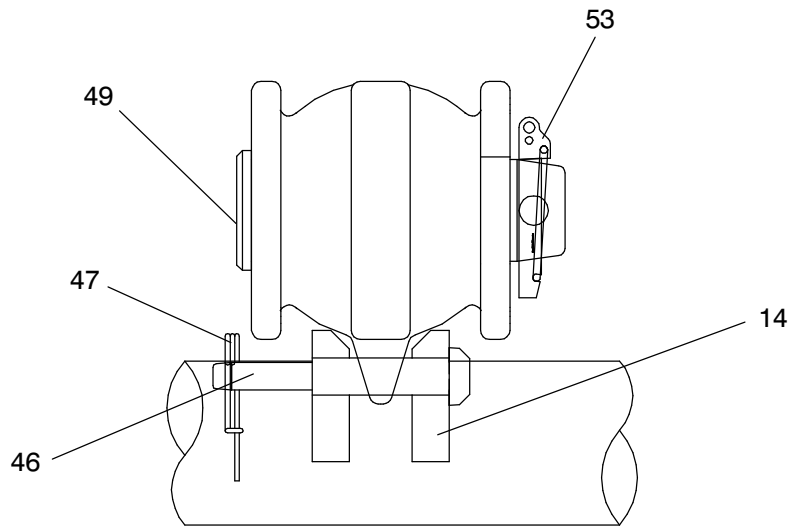

**62-6024**

Seite/Page 2 / 4

Bild-Nr Fig Fig Fig Fig Bild nr	ET-Nr Part-No No. de Piece No. de Pieza No. del Pezzo Detalj nr	Stückzahl Qty Qte Ctd Qta Antal		Gegenstand Description Designation Descripcion Designazione Benaemning
00	100 037 12	1	Zwischenstück 12m kpl.	Extension 12m, assy
01	100 521 12	4	Gabelkopf	Fork end
02	100 047 12	4	Doppelgabelkopf	Double fork end
03	100 546 12	4	Gurtrohr	Chord member
04	880 589 40	2	Rahmenrohr	Frame tube
05	880 591 40	4	Rahmenrohr	Frame tube
06	880 592 40	2	Füllrohr	Spout
07	880 593 40	4	Füllrohr	Spout
08	880 594 40	5	Füllrohr	Spout
09	880 595 40	10	Füllrohr	Spout
10	880 596 40	1	Rohr	Tube
11	880 597 40	5	Füllrohr	Spout
12	880 598 40	2	Füllrohr	Spout
13	100 002 12	4	Konsole	Console
14	103 683 12	4	Konsole	Console
15	100 012 12	8	Stufe	Step
16	102 881 12	1	Seilabweiser	Rope deflector
17	100 017 12	4	Rollenhalter	Retainer for roller
19	515 155 40	4	Bock	Trestle
20	100 021 12	1	Trittlech	Step plate
21	100 020 12	2	Blech	Plate
22	100 019 12	1	Trittlech	Step plate
23	007 267 98	1	Griff	Handle
24	100 022 12	4	Bolzenablage	Pin support
25	657 358 40	2	Kabelhalter	Cable retainer
26	100 010 12	4	Stangenablage	Rod support
27	343 552 44	8	Gewindebolzen	Threaded pin
28	334 678 99	8	Mutter	Nut
29	880 764 40	2	Haltestange 12m	Stay bar 12m
30	100 024 12	2	Rahmenrohr	Frame tube
31	100 025 12	4	Bolzen	Pin
32	342 142 99	4	Splint	Cotter pin
33	513 436 98	8	Scheibe	Disc
34	654 241 40	4	Stützrolle	Roller
35	510 314 98	8	Scheibe	Disc
36	000 950 12	1	Sicherheitsrost	Safety grating
37	000 226 12	1	Sicherheitsrost	Safety grating
38	880 448 40	2	Verbinder	Connector
39	307 756 99	12	Schraube	Bolt
40	509 862 98	12	Mutter	Nut

**Zwischenstück 12 m ( Typ 2724-17-01 )  
Extension 12m**

**62-6024**

Seite/Page 3 / 4

Bild-Nr Fig Fig Fig Fig Bild nr	ET-Nr Part-No No. de Piece No. de Pieza No. del Pezzo Detalj nr	Stückzahl Qty Qte Ctd Qta Antal		Gegenstand Description Designation Descripcion Designazione Benaemning
41	350 763 99	24	Scheibe	Washer
42	100 200 12	14	Bügel	Yoke
43	321 230 99	28	Schraube	Bolt
44	317 318 40	28	Olive	Olive
-	170 470 40	1	Kleber	Adhesive
46	505 903 98	4	Sicherungsbolzen	Lock pin
46	108 510 12	4	Sicherungsbolzen ab Bau Nr.62138	Lock pin from Ser. No. 62138
47	007 266 98	4	Sicherungsfeder	Locking spring
48	100 026 12	4	Steckbolzen	Socket pin
49	100 027 12	2	Steckbolzen	Socket pin
50	100 523 12	1	Schild	Label
51	100 524 12	1	Schild	Label
52	000 376 12	4	Sicherheitsklappstecker	Safety pin
53	512 656 40	2	Klappstecker	Fore lock
55	102 892 12	1	Leitwalze, kpl.	Guide roller, assy
-	634 998 40	1	Schweißdraht	Weld wire
-	604 936 40	1	Schweißdraht	Weld wire
-	592 825 40	1	Schweißdraht	Weld wire

**Zwischenstück 12 m ( Typ 2724-17-01 )  
Extension 12m**

**62-6024**

Seite/Page 4 / 4