

**Kabine
Cabin**

**Kabinenverstellung
Swing-out cabin**

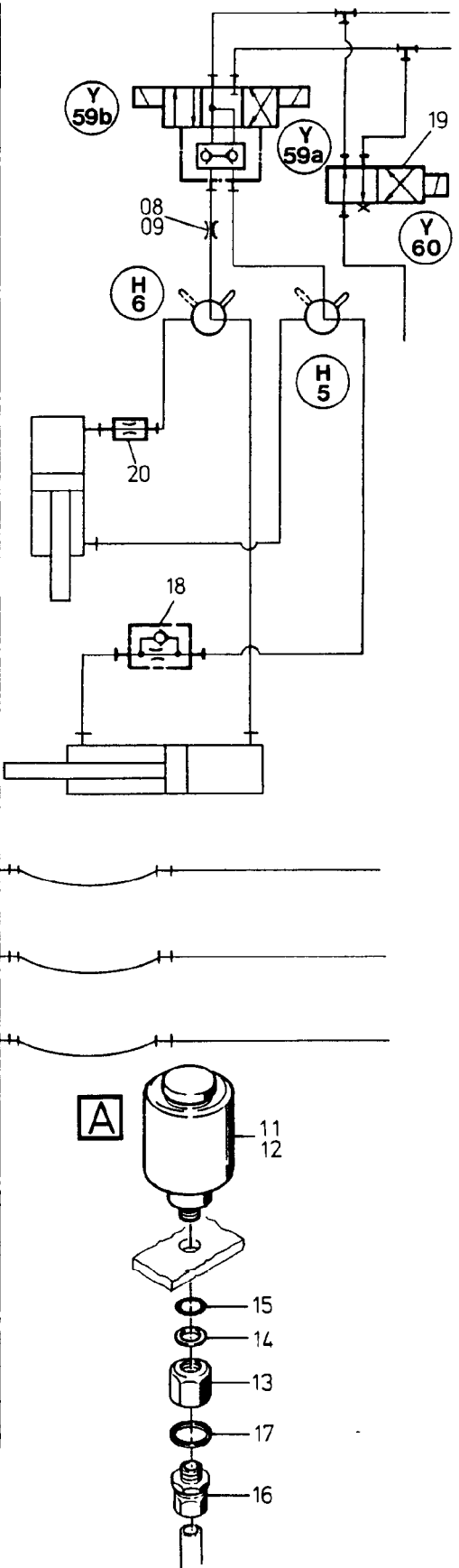
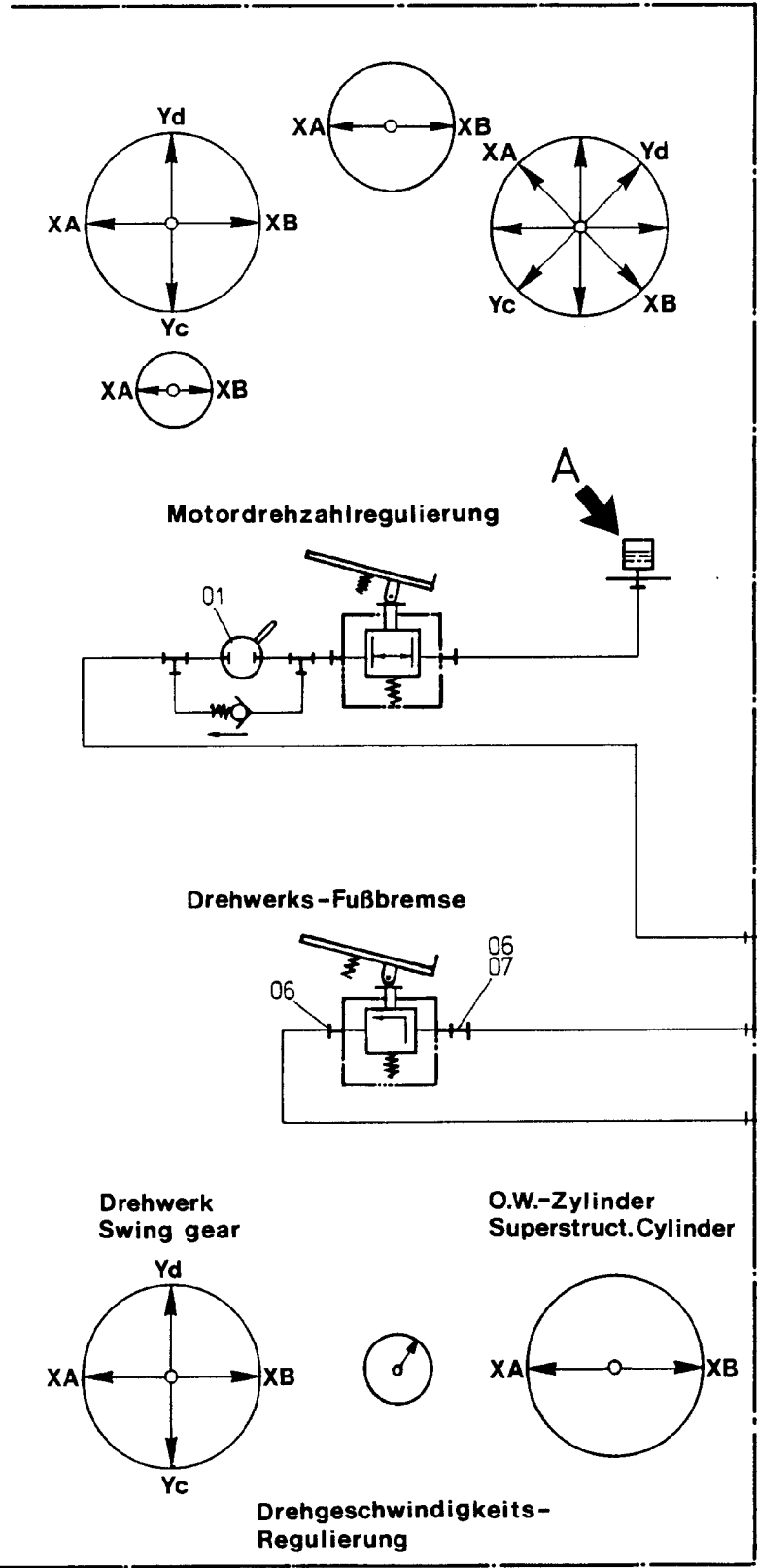

801-1810a

Bild-Nr Fig Fig Fig Fig Bild nr	ET-Nr Part-No No. de Piece No. de Pieza No. del Pezzo Detailj nr	Stückzahl Qty Qte Ctd Qta Antal		Gegenstand Description Designation Descripcion Designazione Benaemning
01	-	1	Drehzahlfeststellung siehe EL-Blatt 52-1811	Rotary joint see page 52-1811
06	372 426 99	2	Verschraubung	Union
07	372 899 99	1	Verschraubung	Union
08	406 046 40	1	Düsenverschraubung	Nozzle union
09	494 377 40	1	Düse	Nozzle
11	084 174 40	1	Ausgleichsbehälter	Expansion tank
12	087 768 40	-	Bremsflüssigkeit	Brake fluid
13	305 870 40	1	Gewindestutzen	Connection piece
14	192 201 40	1	Druckring	Thrust collar
15	192 202 40	1	O-Ring	O-ring
16	372 374 99	1	Verschraubung	Union
17	339 907 99	1	Dichtring	Seal ring
18	326 954 40	1	Drosselventil	Flow control valve
19	492 094 40	1	Magnetventil siehe EL-Blatt 801-1835	Solenoid valve see page 801-1835
20	323 200 40	1	Drossel-Absperrventil	Throttle valve