

804-6135

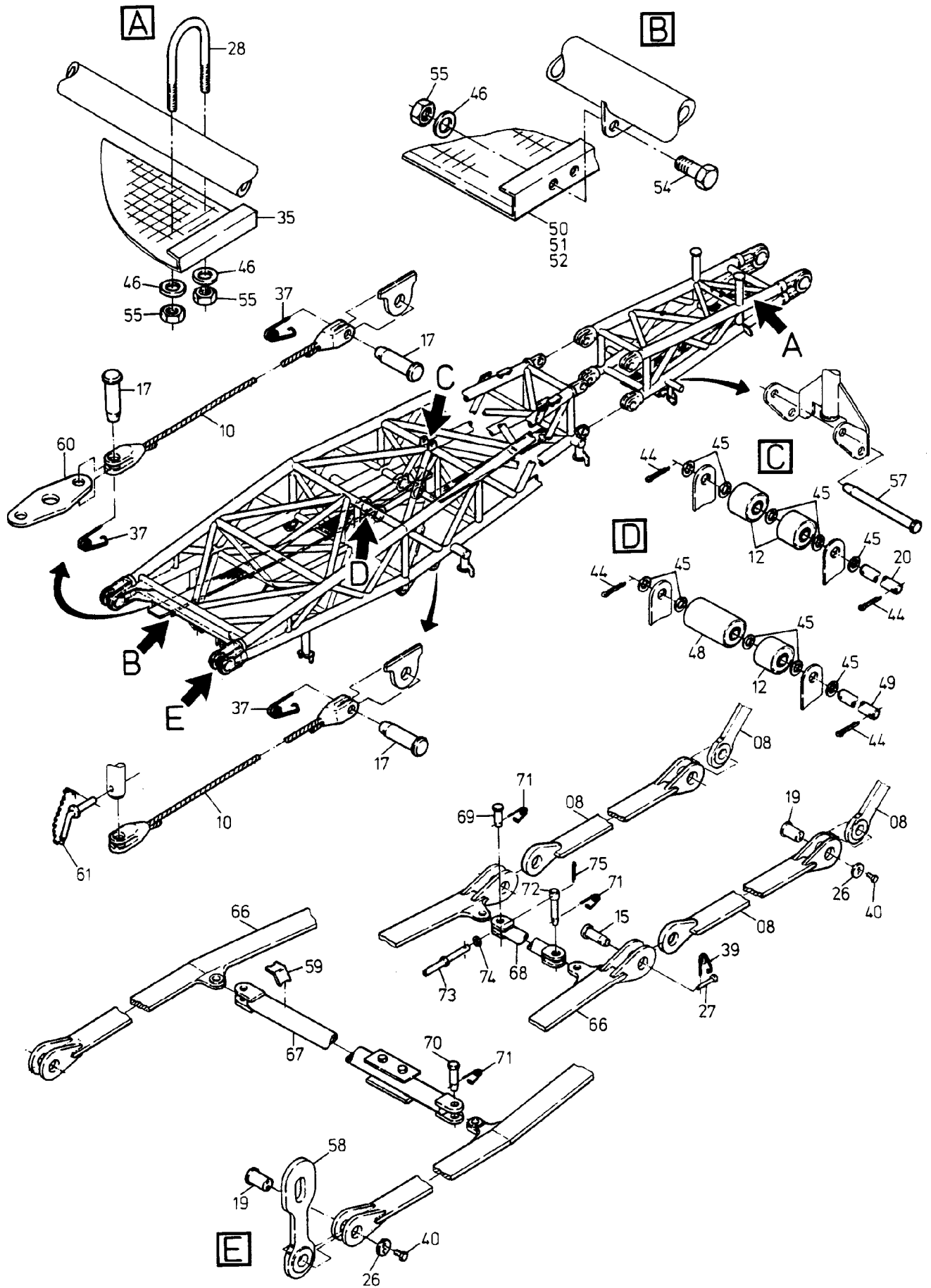

804-6135

| Bild-Nr Fig Fig Fig Fig Bild nr | ET-Nr Part-No No. de Piece No. de Pieza No. del Pezzo Detailj nr | Stückzahl Qty Qte Ctd Qta Antal | | Gegenstand Description Designation Descripcion Designazione Benaemning |
|--|---|--|--|---|
| 00 | 537 450 40 | 1 | Wippstütze, kpl. | Luffing mast assy. |
| 01 | 537 435 40 | 1 | Wippstütze, SK | Luffing mast |
| 02 | - | 1 | Umlenkrolle, kpl. siehe EL-Blatt 801-6140 | Guide Roller assy. see page 801-6140 |
| 03 | - | 1 | Rollensatz, kpl. siehe EL-Blatt 801-6140 | Roller set assy. see page 801-6140 |
| 04 | 460 880 40 | 1 | Seilrolle, kpl ø 1000 | Sheave assy. |
| 05 | 460 660 40 | 4 | Seilrolle, kpl. ø 670 | Sheave assy. |
| 06 | 537 549 40 | 1 | Spreize 10,25m | Expander |
| 07 | 460 855 40 | 1 | Festpunkt, kpl. | Fixed point assy. |
| 08 | 537 455 40 | 2 | Festpunkt, kpl. | Fixed point assy. |
| 09 | 537 452 40 | 2 | Abspannstange 2,6m | Bracing rod |
| 10 | 920 314 40 | 2 | Zwischenseil | Pendant rope |
| 12 | 460 682 40 | 3 | Rolle, kpl. | Roller assy. |
| 13 | 460 860 40 | 1 | Achse | Axle |
| 14 | 460 876 40 | 2 | Bolzen | Pin |
| 15 | 509 104 98 | 2 | Bolzen | Pin |
| 16 | 460 865 40 | 2 | Bolzen | Pin |
| 17 | 001 639 98 | 4 | Steckbolzen | Socket pin |
| 18 | 460 862 40 | 2 | Bolzen | Pin |
| 19 | 537 458 40 | 4 | Bolzen | Pin |
| 20 | 460 870 40 | 1 | Achse | Axle |
| 21 | 444 851 40 | 2 | Achshalter | Axle stirrup |
| 22 | 285 300 40 | 2 | Blech | Plate |
| 23 | 460 859 40 | 2 | Wellenendscheibe | End plate |
| 24 | 371 130 40 | 2 | Achshalter | Axle stirrup |
| 25 | 460 878 40 | 8 | Blech | Plate |
| 26 | 260 923 40 | 4 | Wellenendscheibe | End plate |
| 27 | 505 915 98 | 2 | Sicherungsbolzen | Lock pin |
| 28 | 444 762 40 | 4 | Bügel | Yoke |
| 29 | 460 861 40 | 2 | Distanzrohr | Distance sleeve |
| 30 | 487 217 40 | 3 | Ring | Ring |
| 31 | 460 863 40 | 1 | Rohr | Pipe |
| 32 | 460 869 40 | 4 | Ring | Ring |
| 33 | 537 459 40 | 2 | Blech | Plate |
| 34 | 457 598 40 | 1 | Blech | Plate |
| 35 | 461 409 40 | 1 | Stabilrost | Grid |
| 36 | 001 646 98 | 6 | Sicherungsfeder | Locking spring |
| 37 | 001 645 98 | 4 | Sicherungsfeder | Locking spring |
| 38 | 001 644 98 | 2 | Sicherungsfeder | Locking spring |
| 39 | 007 266 98 | 3 | Sicherungsfeder | Locking spring |
| 40 | 307 823 99 | 12 | Schraube | Bolt |

**Wippstütze
Luffing Mast**

804-6135

Seite/Page 3/4

| Bild-Nr Fig Fig Fig Fig Bild nr | ET-Nr Part-No No. de Piece No. de Pieza No. del Pezzo Detailj nr | Stückzahl Qty Qte Ctd Qta Antal | | Gegenstand Description Designation Descripcion Designazione Benaemning |
|--|---|--|------------------------|---|
| 41 | 307 824 99 | 8 | Schraube | Bolt |
| 42 | 307 844 99 | 4 | Schraube | Bolt |
| 44 | 342 059 99 | 4 | Splint | Cotter pin |
| 45 | 340 469 99 | 10 | Scheibe | Disc |
| 46 | 506 129 98 | 32 | Scheibe | Disc |
| 48 | 509 816 40 | 1 | Rolle | Roller |
| 49 | 488 569 40 | 1 | Achse | Axle |
| 50 | 515 049 40 | 1 | Stabilrost | Grid |
| 51 | 515 229 40 | 1 | Stabilrost | Grid |
| 52 | 515 276 40 | 1 | Stabilrost | Grid |
| 53 | 515 231 40 | 1 | Stabilrost | Grid |
| 54 | 307 779 99 | 24 | Schraube | Bolt |
| 55 | 334 678 99 | 32 | Mutter | Nut |
| 56 | 502 518 98 | 4 | Steckbolzen | Socket pin |
| 57 | 515 303 40 | 4 | Sicherungsbolzen | Lock pin |
| 58 | 537 457 40 | 2 | Abspannstange | Bracing rod |
| 59 | 537 479 40 | 1 | Blech | Plate |
| 60 | 538 662 40 | 1 | Schwinge | Rocker arm |
| 61 | 490 505 40 | 2 | Sicherungsbolzen, kpl. | Lock pin |
| 62 | 504 683 98 | 1 | Rollenlager | Roller bearing |
| 63 | 504 324 98 | 2 | Sprengring | Snap ring |
| 64 | 005 221 98 | 2 | Rollenlager | Roller bearing |
| 65 | 505 941 98 | 4 | Sprengring | Snap ring |
| 66 | 537 551 40 | 2 | Abspannstange | Bracing rod |
| 67 | 537 670 40 | 1 | Druckstrebe | Pressure rod |
| 68 | 499 155 40 | 1 | Zugstrebe | Draw bar |
| 69 | 003 058 98 | - | Steckbolzen | Socket pin |
| 70 | 508 070 98 | 2 | Steckbolzen | Socket pin |
| 71 | 001 645 98 | 4 | Sicherungsfeder | Locking spring |
| 72 | 537 662 40 | 1 | Bolzen | Pin |
| 73 | 537 663 40 | 1 | Bolzen | Pin |
| 74 | 340 471 99 | 1 | Scheibe | Disc |
| 75 | 342 101 99 | 1 | Splint | Cotter pin |
| 77 | 467 071 40 | 2 | Buchse | Bushing |
| 78 | 350 562 99 | 2 | Schmiernippel | Grease nipple |
| 84 | 460 857 40 | 2 | Buchse | Bushing |
| 85 | 350 562 99 | 2 | Schmiernippel | Grease nipple |

**Wippstütze
Luffing Mast**

804-6135

Seite/Page 4/4