

**886-1010E**

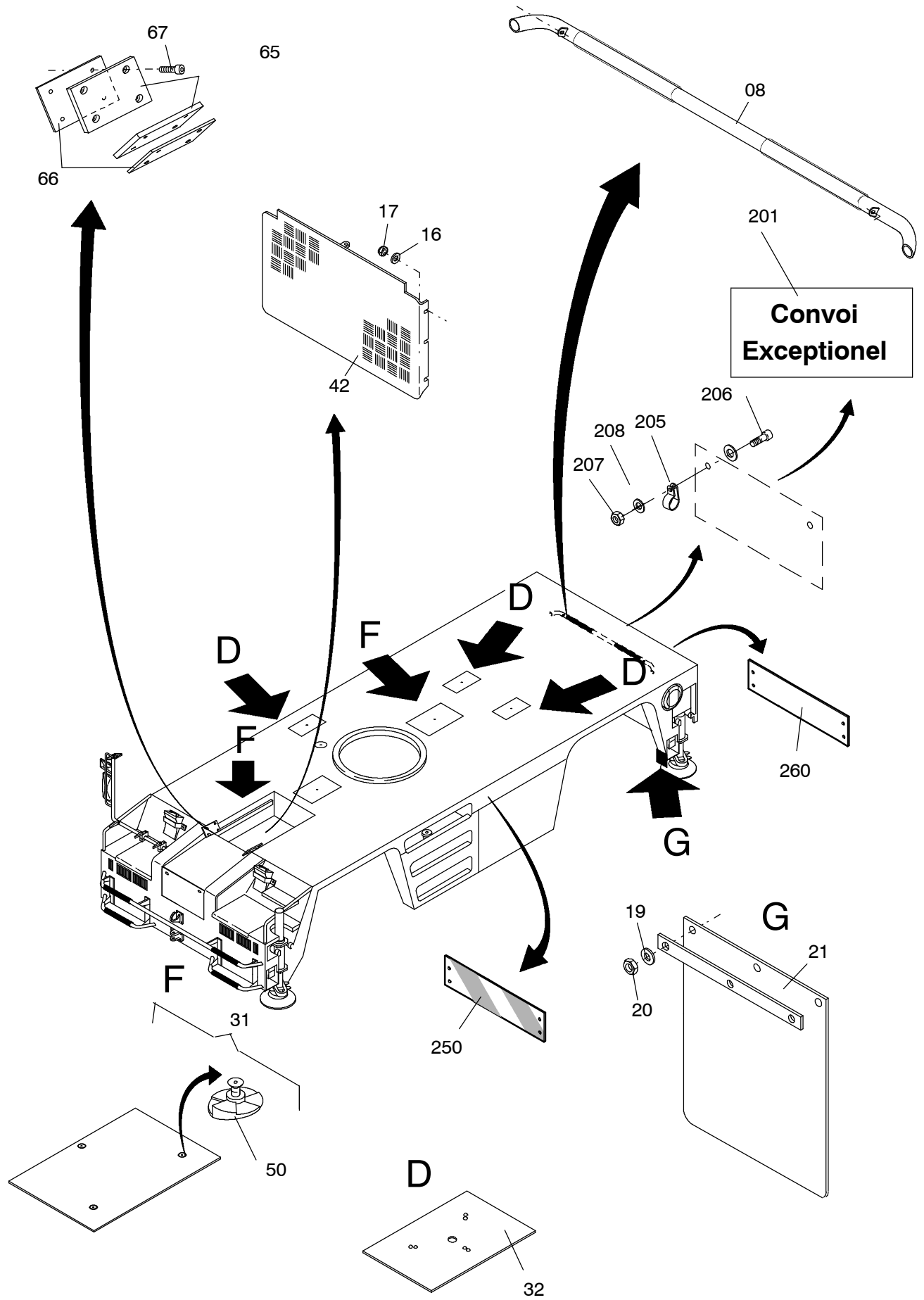

**886-1010E**

Seite/Page 2 / 4

Bild-Nr Fig Fig Fig Fig Bild nr	ET-Nr Part-No No. de Piece No. de Pieza No. del Pezzo Detalj nr	Stückzahl Qty Qte Ctd Qta Antal		Gegenstand Description Designation Descripcion Designazione Benaemning
02	243 649 40	2	Unterlegkeil	Chock
03	243 648 04	2	Unterlegkeilhalter	Retaining device for chock
08	293 182 12	1	Rammschutz	Bumper
13	510 314 98	8	Scheibe	Washer
14	509 759 98	33	Schraube	Sscrew
16	510 321 98	25	Scheibe	Washer
17	509 870 98	8	Mutter	Nut
18	255 616 40	-	Anti-Rutschbelag 900mm Meterware, Länge angeben	Safety rubber Bulk ware, state length required
19	340 506 99	12	Scheibe	Washer
20	509 861 98	6	Mutter	Nut
21	672 293 40	2	Schutzfänger	Dirt trap
22	000 006 12	4	Seilrolle	Sheave
24	000 010 12	1	Vorhängeschloß	Padlock
25	509 869 98	6	Mutter	Nut
26	509 790 98	4	Schraube	Bolt
31	614 278 40	2	Deckel	Cover
32	614 277 40	3	Deckel	Cover
34	614 275 40	1	Deckel	Cover
35	614 768 40	1	Trittstufe	Step
36	614 769 40C	2	Abdeckblech	Cover plate
37	672 026 40	2	Deckel	Cover
38	672 408 40	1	Deckel	Cover
39	672 407 40	1	Klappe, vorne	Flap, front
40	672 519 40	2	Führungsleiste	Guide
41	672 521 40	4	Rohr	Distance pipe
42	672 524 40	1	Trennblech	Plate
50	420 008 12	6	Klemmelement	Clamping element
65	301 552 12	4	Kunststoffplatte	Plastic plate
66	301 553 12	2	Platte	Plate
67	509 818 98	16	Schraube	Bolt
			<b>Kundenwunsch</b>	<b>Customer Equipment</b>
70	673 163 40	1	Haken für Unterflasche	Hook for Hook block
71	303 739 12	1	Zuglasche	Bugle
72	151 356 99	1	Bolzen	Pin
73	151 553 99	1	Bolzen	Pin
74	551 052 40	2	Sicherheitsklappstecker	Fore lock
			<b>Kundenwunsch</b>	<b>Customer Equipment</b>
80	672 041 40	1	Abschleppkupplung, kpl.	Draw bar coupling, assy.
81	655 198 40	1	Abschleppkupplung	Draw bar coupling

<b>Bild-Nr</b> Fig Fig Fig Fig Bild nr	<b>ET-Nr</b> Part-No No. de Piece No. de Pieza No. del Pezzo Detalj nr	<b>Stückzahl</b> Qty Qte Ctd Qta Antal		<b>Gegenstand</b> Description Designation Descripcion Designazione Benaemning
82	655 200 40	1	Bolzen	Pin
83	510 868 98	4	Schraube	Bold
90	197 644 12	1	Spiegelhalter	Mirror bracket,
92	280 678 12	1	Spiegel	Mirror
93	275 911 12	1	Spiegel	Mirror
94	280 626 12	1	Spiegel	Mirror
96	421 660 12	1	Klemmhebel	Clamping lever
97	421 868 12	1	Schraube	Screw
98	126 480 99	1	Schraube	Screw8
99	509 861 98	1	Mutter	Nut
101	509 862 98	4	Mutter	Nut
105	510 321 98	4	Scheibe	Washer
107	340 506 99	4	Scheibe	Washer
110	672 898 40	1	Lagerung	Bearing
111	654 759 40	1	Hakenverschluß	Catch
112	412 059 12	1	Schutzhülle, gelb	Protective hose, yellow
115	510 867 98	2	Klemmhälftenpaar	Pair of half clamps
116	510 080 98	2	Schraube	Screw
117	655 253 40	1	Klappstecker	Circlip
119	511 858 98	2	Deckplatte	Cover plate
120	000 217 40	2	Klemmhebel	Clamping lever
121	125 016 99	2	Schraube	Screw
122	510 028 98	4	Scheibe	Washer
123	510 874 98	2	Schraube	Screw
124	672 899 40	1	Halter	Retainer
125	510 341 98	2	Schraube	Screw
			<b>Kundenwunsch</b>	<b>Customer Equipment</b>
131	673 109 40	1	Aufnahme Unterflasche	Receptacle for Hook block
132	500 544 98	4	Schraube	Screw
205	007 164 98	2	Schelle	Clamp
206	125 517 99	1	Schraube	Screw
207	126 385 99	2	Mutter	Nut
208	507 776 98	4	Scheibe	Washer
250	199 398 12	1	Konturmarkierung	Retroreflective marking
260	199 850 12	1	Nummernschildhalter	Licence plate retainer