

90-0207 a
 Bild 1
 Picture
 folgt Bild 2
 continued

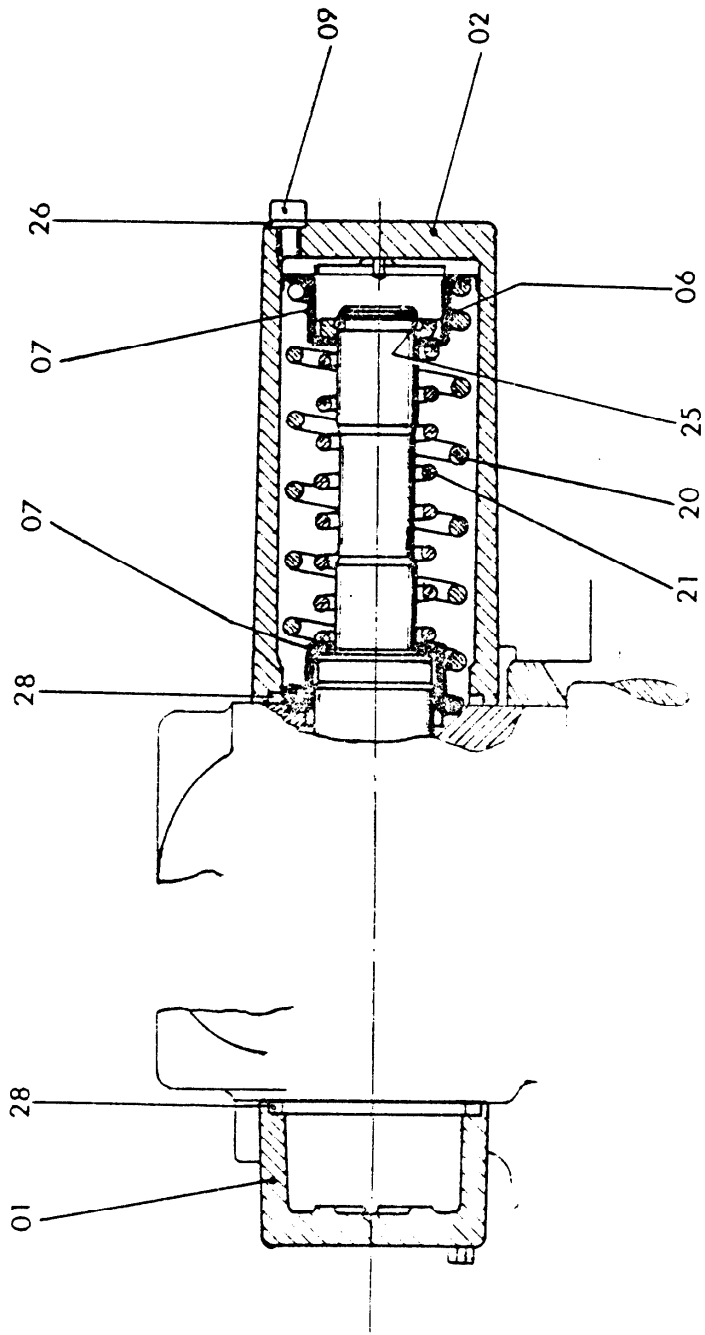

<p>90-0207 a</p> <p>Bild 2 Picture toigt Bild - continued</p>

Bild-Nr. Fig. Fig. Fig. Bild nr.	ET-Nr. Part-No. No. de Piece No. de Pieza No. del Pezzo Detail nr.	Gegenstand Description Designation Description Designazione Benaemning	Stückzahl		135-1805 /19
			Qty. Qte. Ctd. Qta. Antal	X	
--	255 633 40	Steuerblock, kpl. Control block, cpl.	1	x	Rexroth MO 1146-1 AT-Nr.986 493
01	994 405	Deckel, kurz Cover, short	4	x	148 417 4
02	994 406	Deckel, lang Cover, long	4	x	147 031 9
03	994 126	Steuerkolben für Hubwerk I und Teleskop II Piston valve for hoisting gear I and telescop jib II	2		304 677 17
04	994 127	Steuerkolben für Wippwerk und Hubwerk II Piston valve for luffing equipment and hoisting gear II	2		151 081 17
05	994 133	Dichtsatz z. Steuerkolben Seal kit to piston valve	4	x	309 626 -
06	994 128	Ring Ring	4		147 041 18
07	994 129	Federteller Spring cap	8	x	147 042 20
08	994 130	Verschlußschraube Screw plug	1	x	148 441 23
09	961 241	Entlüftungsschraube Breather screw	8	x	117 640
10	999 180	Primärdruckbegrenzungsventil, kpl. Primary pressure relief valve, cpl.	1	x	MO-7001 33
11	997 633	Dichtsatz Seal kit	1	x	309 639
14	962 858	Abspritzventil, kpl. 60 bar einschl. Bild-Nr. 17 Valve, cpl. 60 bar incl. fig-no: 17	1	x	309 057 33
15	962 861	Abspritzventil, kpl. 80 bar einschl. Bild-Nr. 17 Valve, cpl. 80 bar incl. fig-no: 17	2	x	309 057 33
4-fach Steuerblock f. Hubwerk I u. II, Wippwerk u. Teleskop II 4-Section Control Block for Hoisting Gear I and II, Luffing Equipment and Telescope Jib II					90-0207a
					Seite 1 Page 1 folgt Seite 2 continued

26. JUNI 1981

HC 170

F8185 A4747

Bild-Nr. Fig. Fig. Fig. Bildnr.	ET-Nr. Part-No. No. de Piece No. de Pezza No. del Pezzo Detail nr.	Gegenstand Description Designation Descripcion Designazione Benennung	Stückzahl Qty. Qte. Ctd. Qta. Antal	X		
17	962 862	Dichtsatz Seal kit	3	x	309 603	-
18	994 375	Platte einschl. Bild-Nr. 19 Plate incl. fig-no: 19	5		309 083	33
19	994 376	Dichtsatz Seal kit	5	x	309 641	
20	994 407	Feder Spring	4	x	001 684	46
21	994 408	Feder Spring	4	x	001 685	47
22	318 603 99	Schraube Screw	16	x	M6x16 /912-8	58
23	319 227 99	Schraube Screw	20		M6x20 /912-10	59
24	319 231 99	Schraube Bolt	12	x	M6x40 /912-10	60
25	500 063 98	Sprengring Snap ring	4	x	A 18 /7993	71
26	339 861 99	Dichtring Seal ring	8	x	A 6x10 /7603	73
27	180 022 40	O-Ring O-ring	1	x	18,72x2,62	81
28	972 073	O-Ring O-ring	8	x	40,95x2,62	83
					226 320 40	
40	254 540 40	Düseneinsatz Ø 4,5 mm ab Bau-Nr. 82059 u. MHC 190 ab Bau-Nr. 18004 Nozzle insert from serial-no: 82059 and MHC 190 from serial-no: 18004	1	x		243
					ÄÄ 19 313	
41	233 108 40	Düseneinsatz Ø 6 mm ab Bau-Nr. 82 153 u. MHC 190 Nozzle insert from serial-no: 82 153 and MHC 190	1	x		

4-fach Steuerblock f. Hubwerk I u. II, Wippwerk u. Teleskop II
4-Section Control Block for Hoisting Gear I and II, Luffing
Equipment and Telescope Jib II

90-0207a

21. MAI 1985

Seite 2
Page folgt Seite -
continued

AM 10 193
Bi r. 40

F8185 A477