

90-1376

Seite/Page 1 / 5

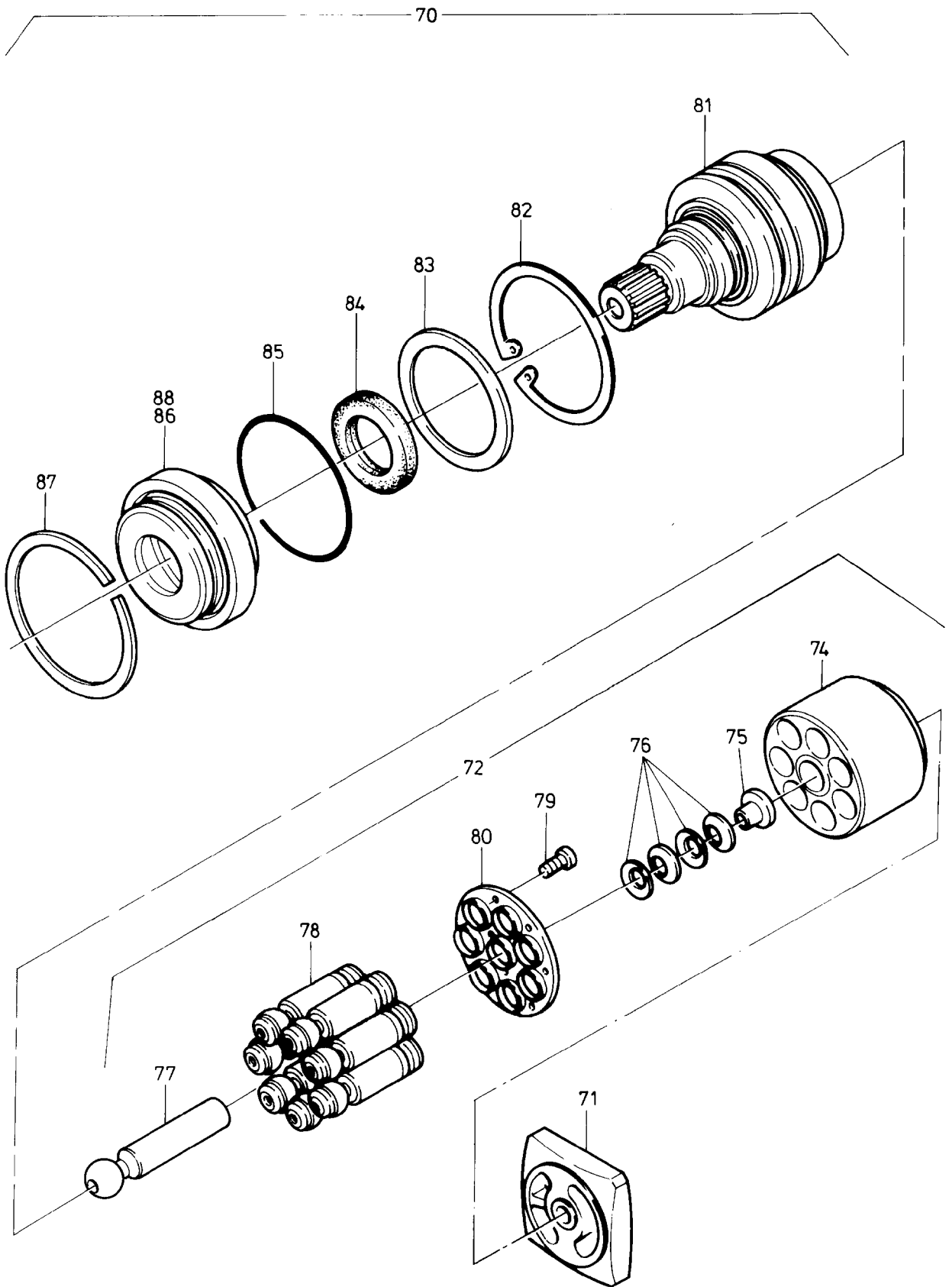

90-1376

Seite/Page 2 / 5

Bild-Nr Fig Fig Fig Fig Bild nr	ET-Nr Part-No No. de Piece No. de Pieza No. del Pezzo Detalj nr	Stückzahl Qty Qte Ctd Qta Antal		Gegenstand Description Designation Descripcion Designazione Benaemning
			Bild 1	Graphic 1
01	394 760 40	1	Hydraulik-Motor, kpl.	Hydraulic motor assy.
02	-	1	Gehäuse	Housing
03	173 448 40	1	Verschlusschraube	Plug
04	756 432 73	1	Verstellung, kpl. Bild-Nr. 05-12, 40-53	Adjustment assy. fig-nos: 05-12, 40-53
05	756 433 73	1	Dichtung	Gasket
06	502 044 98	1	Gewindestift, 80 mm	Thread pin
07	502 594 98	nB	Gewindestift, 90 mm	Thread pin
08	502 595 98	nB	Gewindestift, 100 mm	Thread pin
09	502 596 98	nB	Gewindestift, 110 mm	Thread pin
10	964 767 00	1	Mutter	Nut
11	344 888 99	2	Stift	Pin
12	756 434 73	1	Steuerteil, kpl. Bild-Nr. 13-39	Control part assy. fig-nos: 13-39
13	319 143 99	4	Schraube	Screw
14	756 435 73	1	Steuergehäuse	Control housing
15	505 895 98	1	Gewindestift	Thread pin
16	964 663 00	3	Mutter	Nut
17	325 118 99	2	Gewindestift	Thread pin
18	964 778 00	2	Verschlusschraube	Plug
19	964 770 00	4	Abreißstopfen	Breaking plug
20	756 436 73	1	Verschlusschraube	Plug
21	505 893 98	1	O-Ring	O-ring
22	756 437 73	2	Federteller	Spring plate
23	756 438 73	1	Druckfeder	Compression spring
24	756 439 73	1	Druckfeder	Compression spring
25	756 440 73	1	Steuerbuchse	Sleeve
26	756 441 73	1	Steuerkolben	Piston valve
27	756 442 73	1	Bolzen	Pin
28	972 073 00	1	O-Ring	O-ring
29	756 443 73	1	Druckfeder	Compression spring
30	756 444 73	1	Federteller	Spring plate
31	756 445 73	1	Druckfeder	Compression spring
32	756 446 73	1	Einstellbuchse	Bush
33	756 447 73	1	Druckfeder	Compression spring
34	756 448 73	1	Federbolzen	Spring bolt
35	345 576 99	1	Stift	Pin
36	342 616 99	1	Sicherungsring	Circlip
37	756 449 73	1	Steuerbuchse	Sleeve
38	756 450 73	1	Steuerkolben	Piston valve

Hydraulik-Motor
Hydraulic Motor

90-1376

Seite/Page 3 / 5

Bild-Nr Fig Fig Fig Fig Bild nr	ET-Nr Part-No No. de Pieca No. de Pieza No. del Pezzo Detalj nr	Stückzahl Qty Qte Ctd Qta Antal		Gegenstand Description Designation Descripcion Designazione Benaemning
39	505 894 98	1	Gewindestift	Thread pin
40	319 187 99	8	Schraube	Bolt
41	964 736 00	1	Abreibstopfen	Breaking plug
42	504 844 98	3	O-Ring	O-ring
43	756 451 73	1	Abschlußplatte	Cover plate
44	756 452 74	2	Ventilführung	Valve guide
45	756 453 73	2	Bolzen	Pin
46	756 454 73	2	Buchse	Bush
47	756 455 73	1	Stellzapfen	Regulation journal
48	756 456 73	2	Stützring	Support ring
49	756 457 73	1	Variseal-Ring	Variseal-ring
50	756 458 73	1	Stellkolben	Piston
51	756 354 73	2	Rechteckring	Quadring
52	753 131 00	1	Gewindestift	Thread pin
53	756 460 73	1	Deckel, kpl. Bild-Nr. 54-60	Cover assy. fig-nos: 54-60
54	319 157 99	4	Schraube	Bolt
55	756 459 73	1	Deckel	Cover
56	504 600 98	1	O-Ring	O-ring
57	171 260 40	1	Verschlussschraube	Plug
58	756 461 73	1	Drosselschraube	Throttle screw
59	756 462 73	1	Drosselschraube	Throttle screw
60	756 463 73	1	Drosselstift	Reset pin
			Bild 2	Graphic 2
70	756 464 73	1	Triebwerk, kpl. Bild-Nr. 71,72,81-87	Transmission assy. fig-nos: 71,72,81-87
71	756 465 73	1	Steuerlinse	Control lens
72	754 672 00	1	Triebwerk, hydr. Teil Bild-Nr. 73-80	Transmission, hydr. part fig-nos: 73-80
74	754 673 00	1	Zylinder	Cylinder
75	754 674 00	1	Federteller	Spring plate
76	754 675 00	4	Tellerfeder	Cup spring
77	754 676 00	1	Mittelzapfen	Trunnion
78	756 466 73	7	Kolben	Piston
79	753 682 00	14	Schraube, brüniert	Screw, burnished
80	998 793 00	1	Rückzugplatte	Withdrawal plate
81	756 467 73	1	Triebwelle mit Lagersatz	Drive shaft with bearing set
82	342 682 99	1	Sicherungsring	Circlip
83	754 679 00	1	Stützscheibe	Supporting disk
84	504 216 98	1	Wellendichtring *	Shaft seal
85	006 746 98	1	O-Ring	O-ring

Hydraulik-Motor
Hydraulic Motor

90-1376

Seite/Page 4 / 5

Bild-Nr Fig Fig Fig Fig Bild nr	ET-Nr Part-No No. de Piece No. de Pieza No. del Pezzo Detalj nr	Stückzahl Qty Qte Ctd Qta Antal		Gegenstand Description Designation Descripcion Designazione Benaemning
86	754 681 00	1	Verschlußring *	Cover
87	754 682 00	1	Sprengring	Snap ring
88	756 468 73	1	Verschlußring, kpl. mit Bild-Nr. 84	Cover assy. with fig-no: 84
-	756 469 73	-	Dichtsatz, kpl.	Seal kit assy.
-	973 125 00	-	Flüssigdichtung 50 ml zu Bild-Nr. 39,79	Fluid sealing to fig-nos: 39,79
-	989 946 00	-	Flüssigdichtung 50 ml (Rohrgewinde)	Fluid sealing (pipe thread)
			* Diese Teile können nur bei Werkstattreparatur verwendet werden	* No field repair item